



## Model G48-series

### AC Motor Controllers 48V, 450 and 650A

Model G48-series represent the latest design standards for compact and reliable AC Controllers. It features the smallest footprint in the industry for its power capability. The high efficiency of this controller makes it possible to integrate it into very tight spaces without sacrificing performance. The design has been optimized for lowest possible installed cost while maintaining superior reliability in the most demanding applications.

#### Fully CANopen Compliant

These controllers come standard with CANopen. This allows easy interconnection of controllers and other devices such as displays and driver controls. CANopen also allows the user to wire the vehicle to best suit vehicle layout since inputs such as the throttle can be connected to any of the controllers on the vehicle and the demand value will be passed over the CAN-open bus to the relevant motor controller.

#### Additional Features

- Designed for highest reliability
- Integrated logic circuit
- Advanced flux vector control
- Sensorless control for select applications
- Autocheck - system diagnostics
- Hardware and software failsafe/watchdog operation
- Integrated fuse holder

#### Choice of Motor Technologies

The Gen4 controllers are capable of controlling AC Asynchronous motors as well as Permanent Magnet Synchronous motors. This feature allows users to select optimal motor solutions for any application. Both UVW and encoder AB inputs are provided for maximum flexibility.



# Gen4™

## Self-characterization

Sevcon's unique Self Characterization capability enables G48-series controllers to automatically define and optimize parameters for the AC motor. This feature provides quick set-up and allows customers to select motor suppliers of their choice without worrying about compatibility between controller and motor.

## Integrated I/O

This unit includes a cost-effective, fully-integrated set of inputs and outputs (I/O) designed to handle a wide range of vehicle requirements. This eliminates the need for additional external I/O modules or vehicle controllers and connectors

## Overall Dimensions

Model G4845

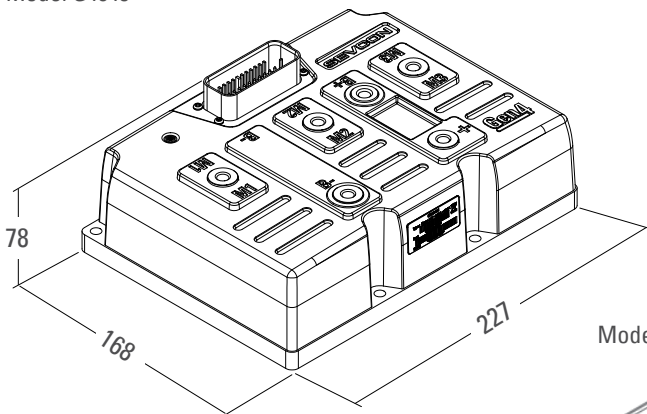

Model G4865

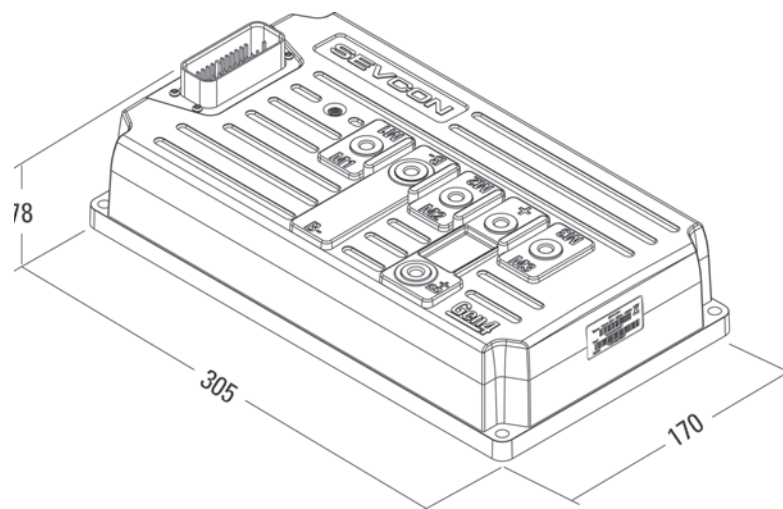

## General Specifications

Model	G4845	G4865
Nominal battery voltage	36 or 48VDC	
Peak current (2 min)	450A	650A
Boost current (10 sec)	540A	780A
Digital inputs	8	
Analog inputs	2	
Motor temperature sensor input	Yes	
Contactors/solenoid outputs (2A)	3	
Motor UVW inputs	Yes	
Motor encoder (AB) inputs	Yes	
Encoder supply output	5V or 10V (max. 100mA)	
Supported CANopen profiles	DS301, DS401, DS402	
Ambient operating temperature	-40°C to +85°C	
Protection class	IP66	

Sevcon Ltd.  
Kingsway South  
Gateshead, NE11 0QA  
England  
Tel +44 (0)191 497 9000  
Fax +44 (0)191 482 4223  
sales.uk@sevcon.com

Sevcon, Inc.  
155 Northboro I  
Southborough, MA 01772  
USA  
Tel +1 508 281 5500  
Fax +1 508 281 5341  
sales.us@sevcon.com

[www.sevcon.com](http://www.sevcon.com)

TECH/OPS  
**SEVCON**®

Partner with Performance™