

Power Management Guide



Automotive
Communications
Computing
Consumer
High Reliability
Industrial



→ Table of Contents

Texas Instruments (TI) offers complete power solutions with a full line of high-performance products. These products, which range from standard linear regulators to plug-in and integrated power solutions, are tailored to meet your design challenges. And, TI makes designing easier by providing leading-edge support tools such as training, a broad selection of evaluation modules (EVMs), application notes, comprehensive technical documentation and more. TI also offers samples and small orders (shipped within 24 hours via TI authorized distributors) that will help you accelerate your time-to-market.

Included in this selection guide you will find design factors, featured products, graphic representations of portfolios and parametric tables. Also identified are devices qualified for HiRel and automotive applications. Some device options may not be available and pricing will be different.

For more information about HiRel and military versions of Power Management products, please visit:

www.ti.com/hirel

For more information about automotive-qualified Power Management products, please visit:

www.ti.com/automotive

Typical Power Applications	3
Line Power and Portable Power Solutions	3
AC/DC and Isolated DC/DC Solutions	4
DM335 and DM355 Processor Power Solutions	5
TMS320™, MSP430™ and Stellaris™ Processor Power Solutions	6
OMAP35x Processor Power Solutions	7
Low-Power Intel® Atom™ Processor Power Solutions	8
FPGA and CPLD Power Solutions	9
Active-Bus Termination Solutions	11
Digital Power Control Solutions	12
Introduction	12
Digital Power	13
AC/DC and DC/DC Power Supply Products	15
Power Factor Correction (PFC)	15
PWM Power Supply Controllers	17
MOSFET Drivers	22
Plug-In Power Modules	24
Linear Regulators	27
Linear and Low Dropout (LDO) Regulators	27
Non-Isolated Switching DC/DC Regulators	31
DC/DC Controllers (External Switch)	31
DC/DC Converters (Integrated Switch)	33
Inductorless DC/DC Regulators (Charge Pumps)	38
Multi-Output Solutions	40
Power Management Units	40
Lighting and Display Solutions	42
LED Lighting Controller	42
White LED Backlight, High-Current LED and LED Flashlight Drivers	43
LED Display Drivers	45
LCD Bias Power	47
Photoflash Capacitor Chargers and Xenon Flashlight Drivers	49
Battery Management Products	50
Charger Front-End Protection	50
Battery Charge Management	50
Battery Fuel Gauges	52
Lithium-Ion Protection	54
Authentication for Batteries and Peripherals	55
Hot Swap and Power Distribution	55
Power-over-Ethernet	55
Hot Swap Power Management	58
Load Switches	61
USB Devices	63
Power Multiplexers and ExpressCard™ Power Switches	64
USB Current-Limiting Switches	65
Supervisors, Reset ICs and Sequencers	67
Voltage References	70
NexFET™ Power MOSFETs	72
Resources	74
Design Support	74
Packaging	76
Device Index	78
TI Worldwide Technical Support	82



Line Power Solutions

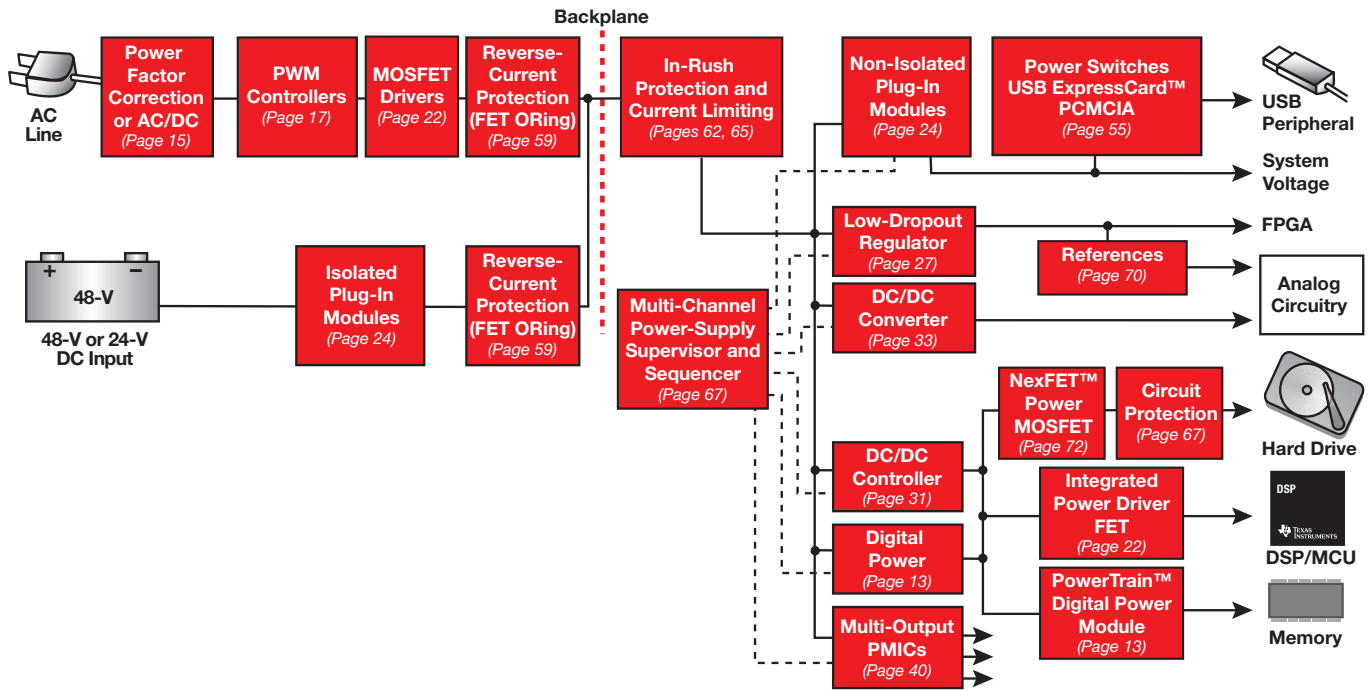

Portable Power Solutions

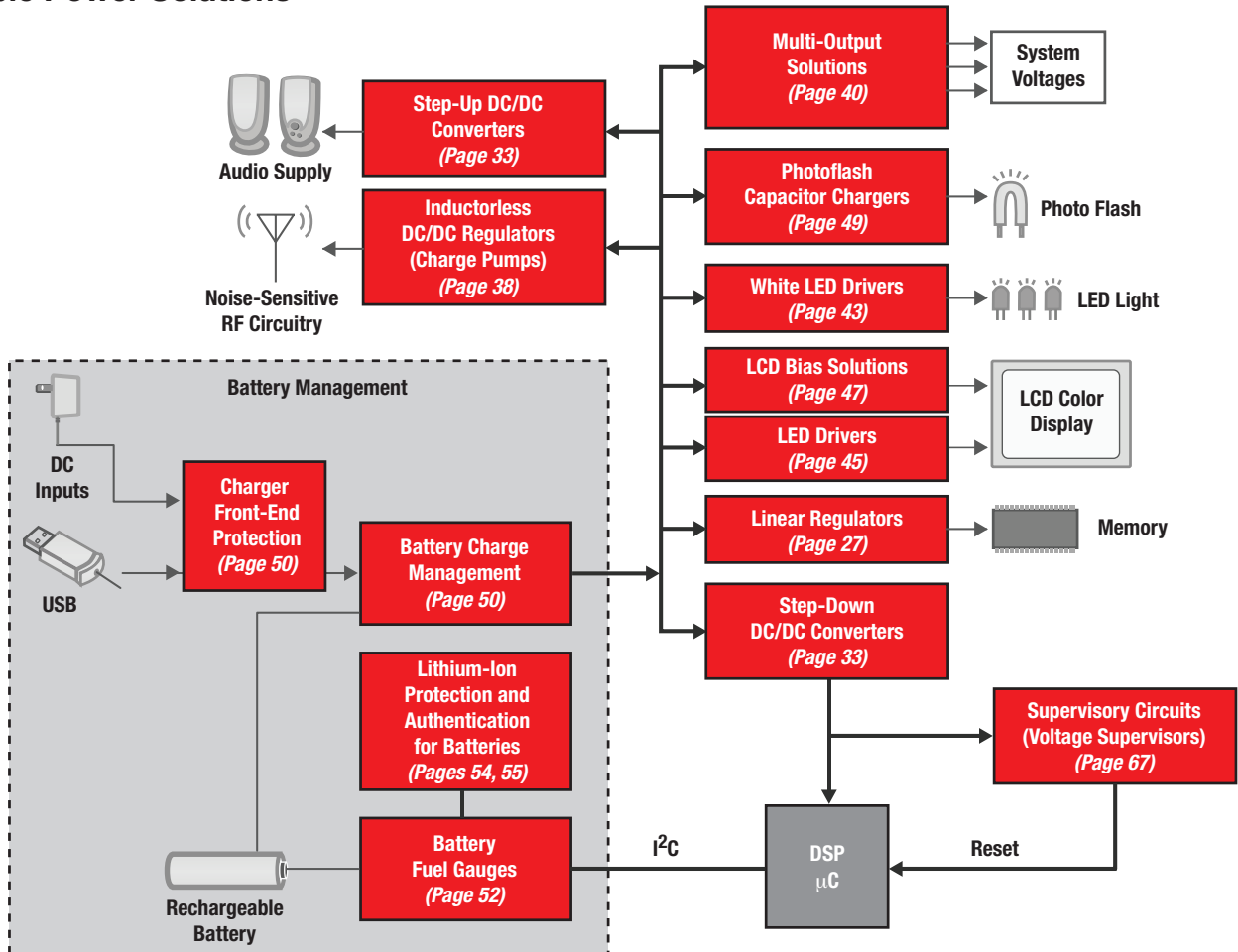



AC/DC Solutions

Isolated DC/DC Solutions

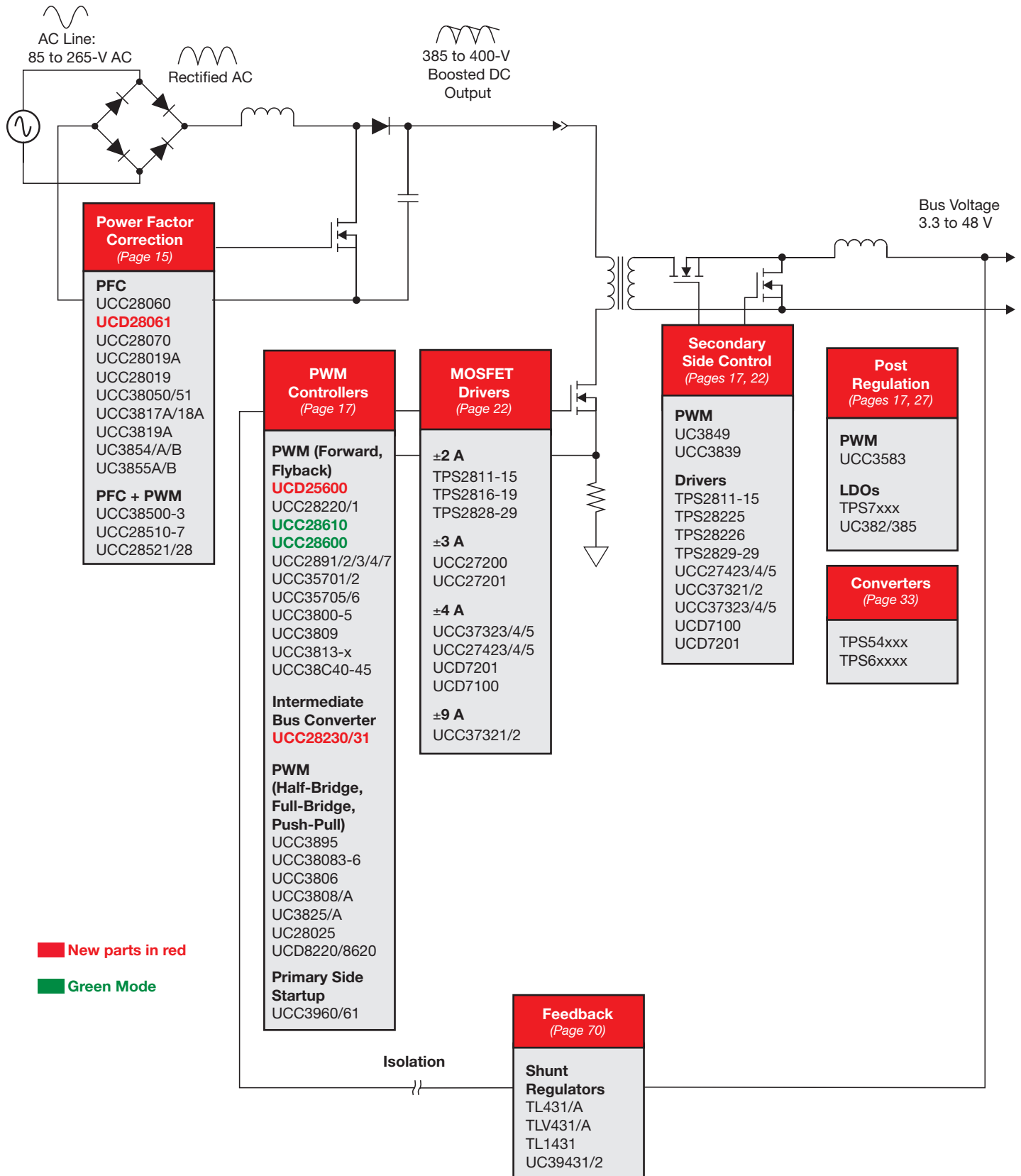

■ New parts in red

■ Green Mode



Power management products from Texas Instruments provide optimized power for your DSP, FPGA, or any other processor. Whether you are creating a battery-powered handheld device or a high-power wireless base station, you'll find processor power solutions that meet the stringent requirements of these applications. The designs and block diagrams on the next few pages highlight a few of these solutions.

DM335 and DM355 Processor Power Solutions

www.ti.com/processorpower

Highest Efficiency

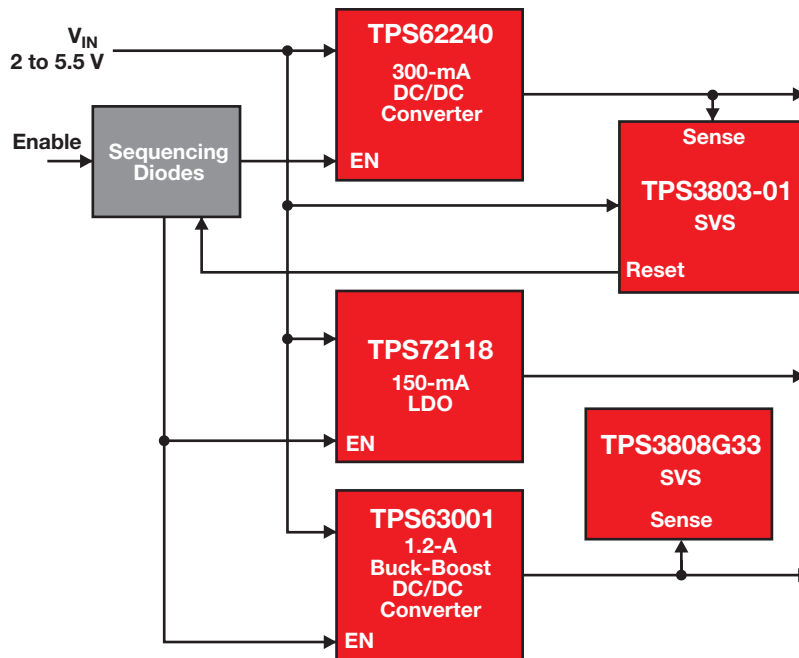

Wide V_{IN} , high-efficiency, discrete power solution.

Most Integration

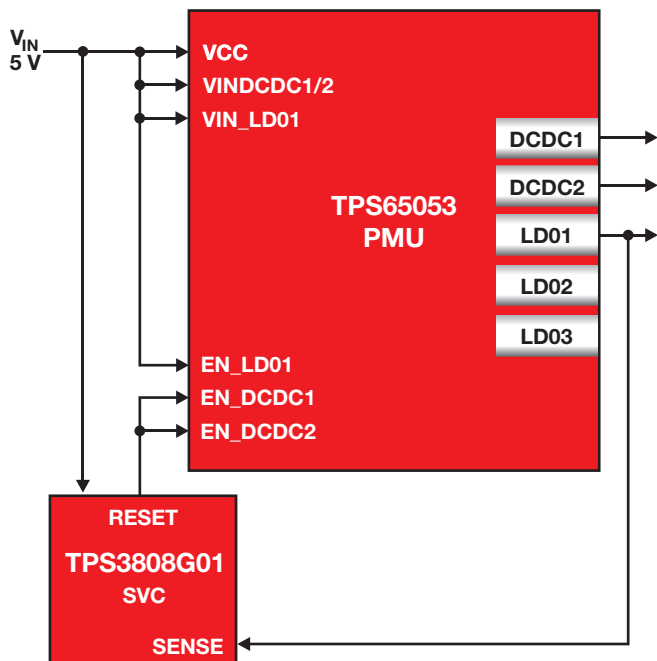

Multiple-output DC/DC converter with integrated FETs.

Simplest Solution

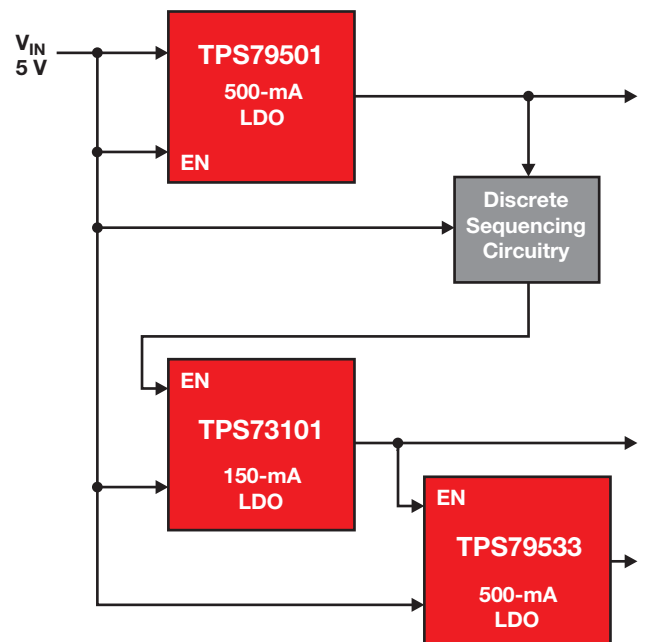

LDO power solution.



TMS320™, MSP430™ and Stellaris™ Processor Power Solutions

www.ti.com/processorpower

TMS320C6474 DSP Reference Design

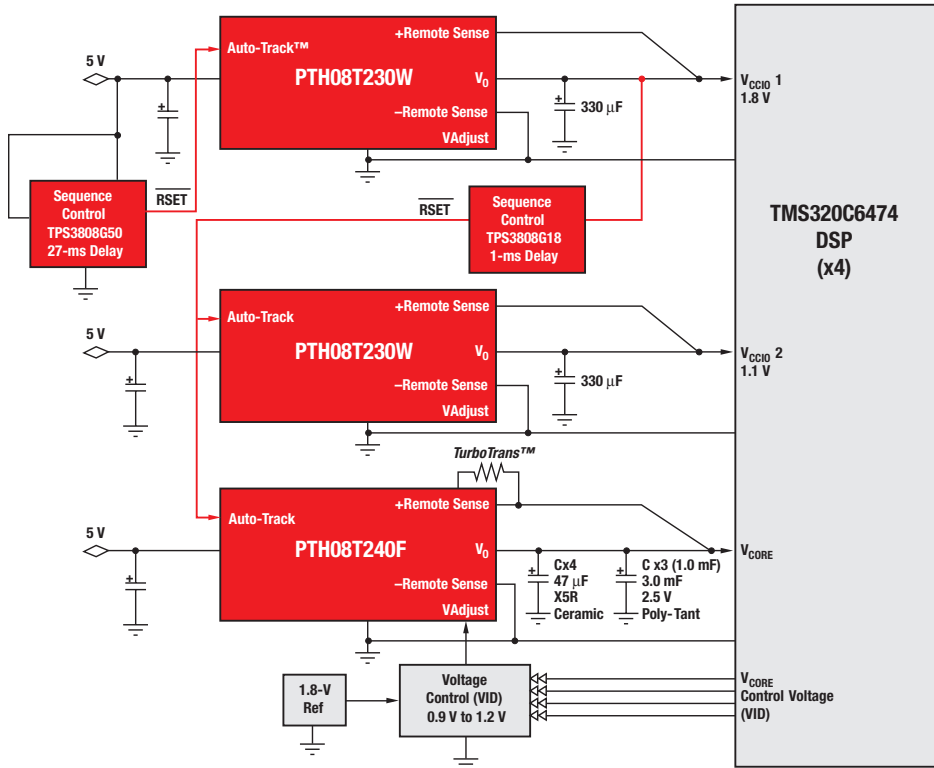

MSP430 and Stellaris Processor Power Solutions

Small Solution Size and High Efficiency

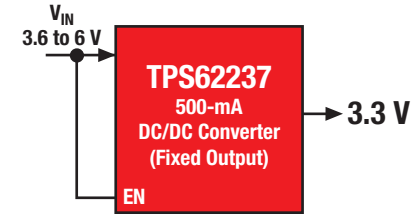

DC/DC converter with integrated FETs.

Simple and Long Battery Life

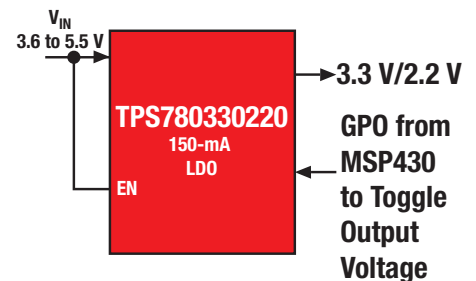

Single-output LDO with DVS.

Power Management for MSP430 and Stellaris Microcontrollers Selection Guide

Regulator Type	Device ¹	I ₀ (mA)	V _{D0} at I ₀ (mV)	I _q (µA)	Fixed Voltage (V)	Min V _{IN} (V)	Max V _{IN} (V)	Accuracy (%)	Package(s)	Features ²	C ₀ ³	Comments	Price*
Linear	TPS797xx	50	105	1.2	1.8, 2.85, 3.0, 3.3	1.8	5.5	4	SC70	PG	1.0 µF, C	Low I _q	0.34
Linear	TPS780xx	150	130	0.5	3.3/2.2, 2.3/3.0, 2.7/2.0, 3.0/2.5, Adj., EEPROM ⁴	2.2	5.5	3	SOT23, QFN	EN, VSET1	1.0 µF, C	Dual-level output, low I _q	0.65
Linear	TPS781xx	150	130	1	3.3/2.2, Adj., EEPROM ⁴	2.2	5.5	3	SOT23, QFN	EN, VSET1	1.0 µF, C	Dual-level output, low I _q	0.50
Linear	TPS782xx	150	130	1	2.3, 2.5, 2.7, 2.8, 3.0, 3.3, EEPROM ⁴	2.2	5.5	3	SOT23, QFN	EN	1 µF, C	Low I _q	0.34
High V_{IN}													
Linear	TPS715xx	50	415	3.2	1.8, 1.9, 2.3, 2.5, 3.0, 3.3, 4.5, 5.0, Adj.	2.5	24	4	SC70	—	1 µF, C	Wide V _{IN} , low I _q	0.34
Linear	TPS714xx	80	615	3.2	3.3	2.5	10	4	SC70, QFN	—	1 µF, C	Wide V _{IN} , low I _q	0.24
Linear	TPS715Axx	80	670	3.2	3.3, Adj.	2.5	24	4	—	—	1 µF, C	Wide V _{IN} , low I _q	0.44
High Efficiency													
DC/DC	TPS63030	500	—	25	3.3, Adj.	1.8	5.5	1	QFN	Full battery range use	10 µF	Buck-boost	1.20
DC/DC	TPS61220	100	—	5.5	3.3, 5, Adj.	0.7	5.5	3	SC70	Low I _q , low V _{IN}	10 µF	Boost	0.65
DC/DC	TPS61097	100	—	5	3.3	0.9	5.5	3	SOT23	Low I _q , bypass switch	10 µF	Boost	0.80
DC/DC	TPS62270	400	—	15	0.9/1.0, 2.2/3.3, 2.5/3.3	2	6	<2	QFN	Dynamic VSEL	10 µF	Step-down	0.95
DC/DC	TPS62230	500	—	22	1.8, 2.0, 2.1, 2.25, 2.3, 2.5, 2.7, 2.9, 3.0, 3.3	2.05	6	2	QFN	Small solution size	4.7 µF	Step-down	0.45

¹xx represents the voltage option. For example, 33 represents the 3.3-V option. The adjustable output voltage option is represented by 01.

²EN = active high enable, PG = Power Good, VSET is the ability to toggle between two output voltages H/L on the VSET pin.

³C = ceramic.

⁴EEPROM programmable at the factory, allowing production of custom fixed voltages. Minimum quantities apply. Please contact TI.

*Suggested resale price in U.S. dollars in quantities of 1,000.

New devices are listed in bold red.



OMAP35x Processor Power Solutions

www.ti.com/processorpower

The OMAP35x family of processors are capable of communicating via I²C bus with the devices providing them power. The OMAP35x processors optimize power consumption through dynamic voltage frequency scaling and SmartReflex™ design software. Both the TPS65073 and TPS65023 have integrated I²C ports for optimal communication with OMAP35x processors.

OMAP35x Power Supply Using the TPS65073

The TPS65073 is an integrated power management IC with three DC/DC converters, two LDOs, battery charger, touch-screen controller and WLED driver.

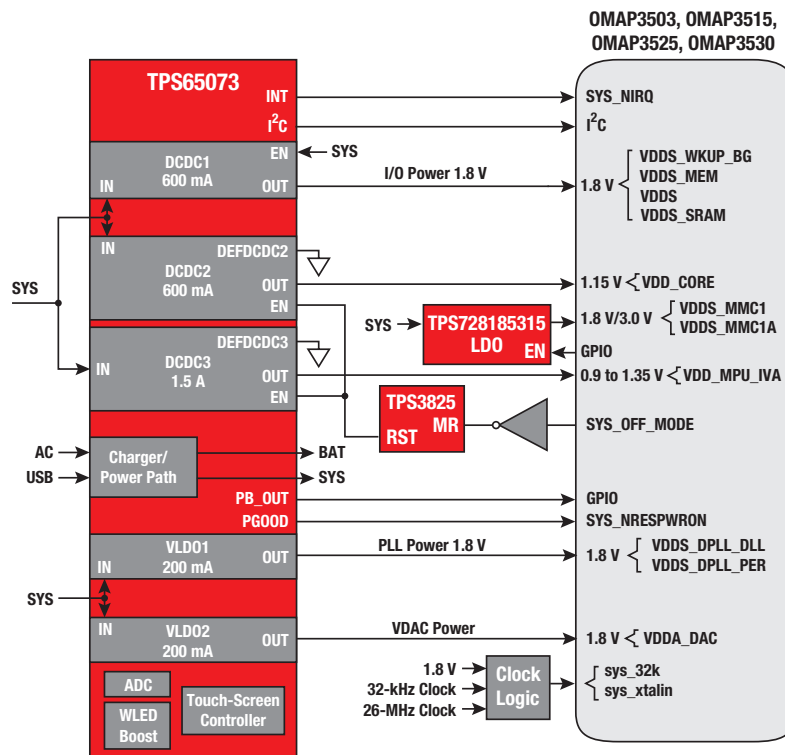

OMAP35x Power Supply Design Using the TPS65023 and TPS72118

The TPS65023 is a 6-channel power management IC with three DC/DCs, three LDOs, I²C interface and dynamic voltage scaling.

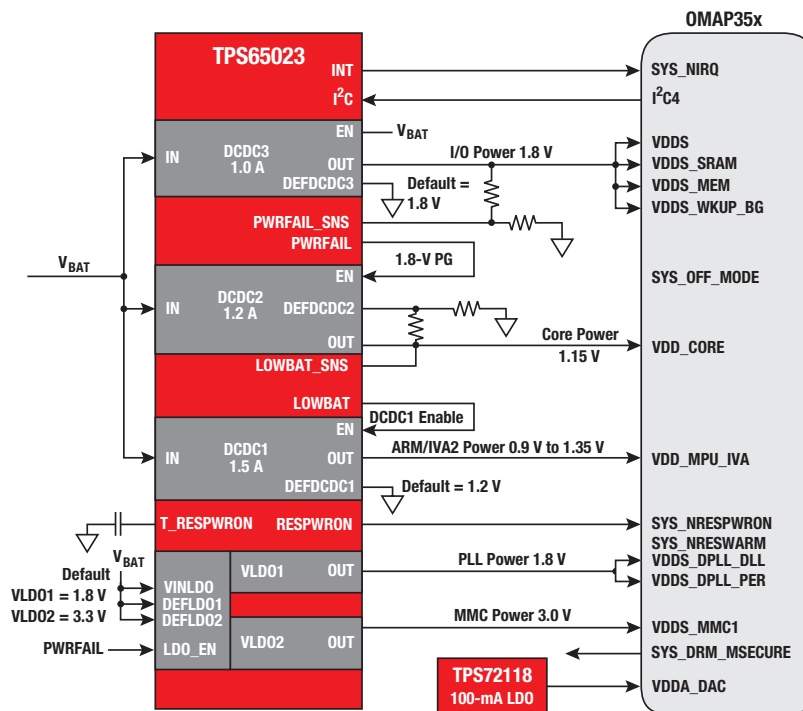



Low-Power Intel® Atom™ Processor Power Solutions

www.ti.com/imvp6

TI has integrated power solutions that are specially designed for use in low-power CPUs and Intel integrated graphics solutions for computing systems. Also, TI's NexFET™ technology offers low on-resistance switches with extremely low gate charge that allows designers to achieve 90% power-supply efficiency at all load levels.

IMVP6+ Atom Processor (N270, N450, Z5xx Series) Power Solutions with Green Mode

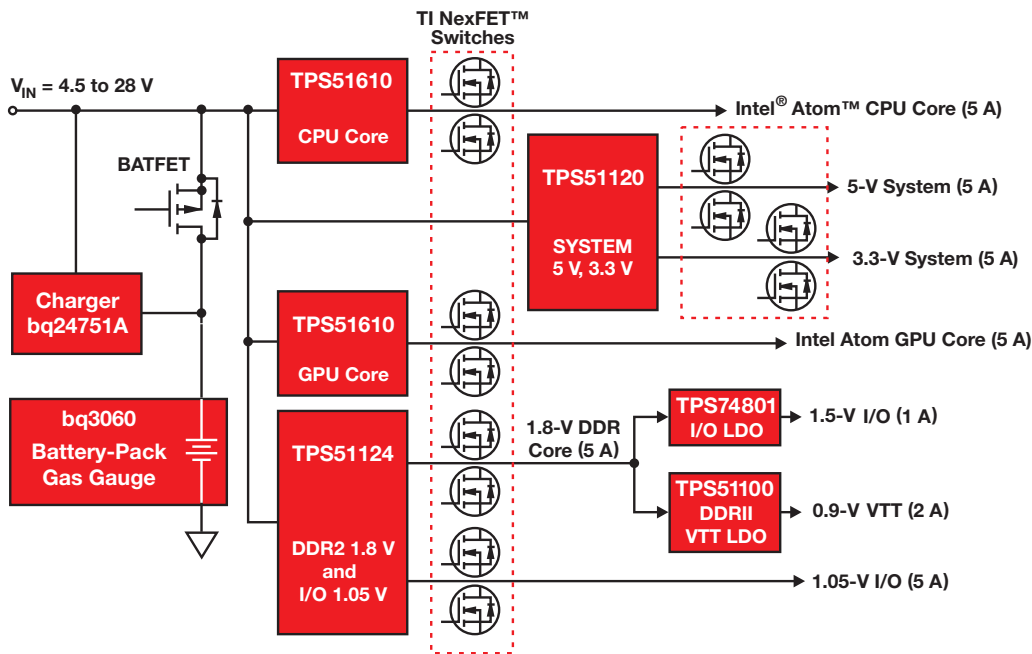

IMVP6+ Atom Processor (N270, N450, Z5xx Series) Power Solutions with SWIFT™ Integrated FET Controllers and TI NexFET™ Switches

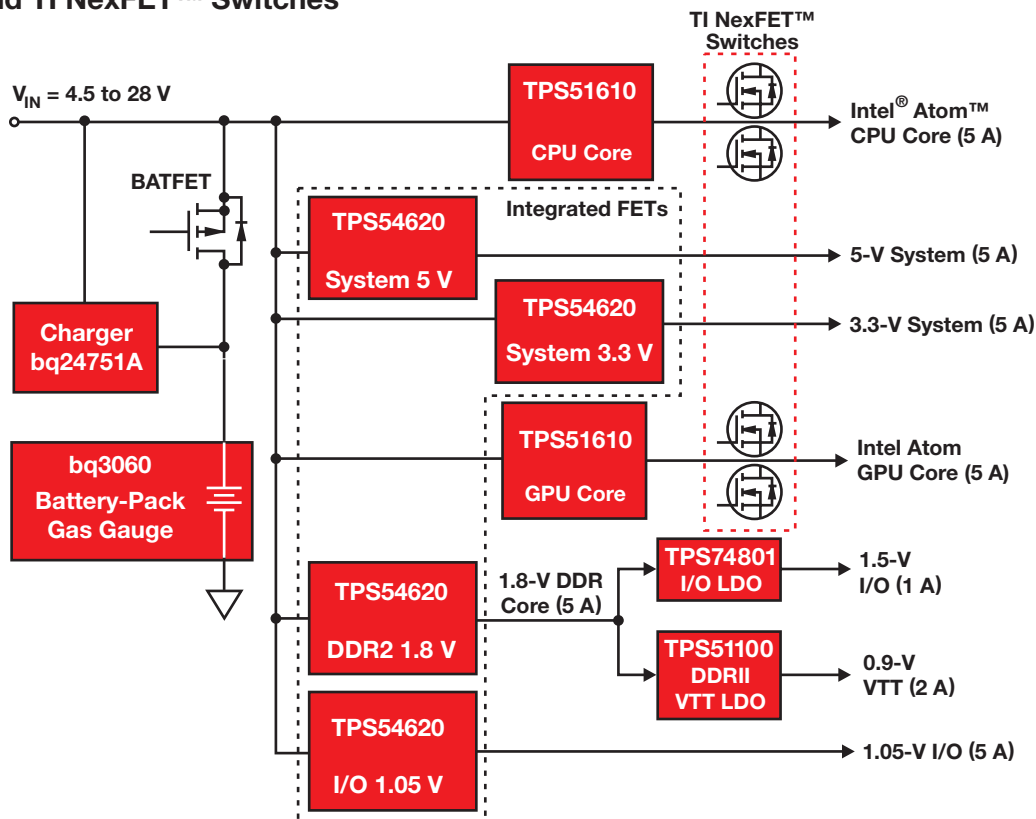



FPGA and CPLD Power Solutions

www.ti.com/xilinxfpga or www.ti.com/alterafpga

Access the sites for one-stop power management support for Xilinx® and Altera® FPGAs and CPLDs, including free downloads of power reference designs with complete schematics, bills-of-material and helpful implementation notes.

Plug-In Power Modules in a Power Distribution System for Altera Stratix® IV EP4SGX360 and EP4SGX530 FPGAs

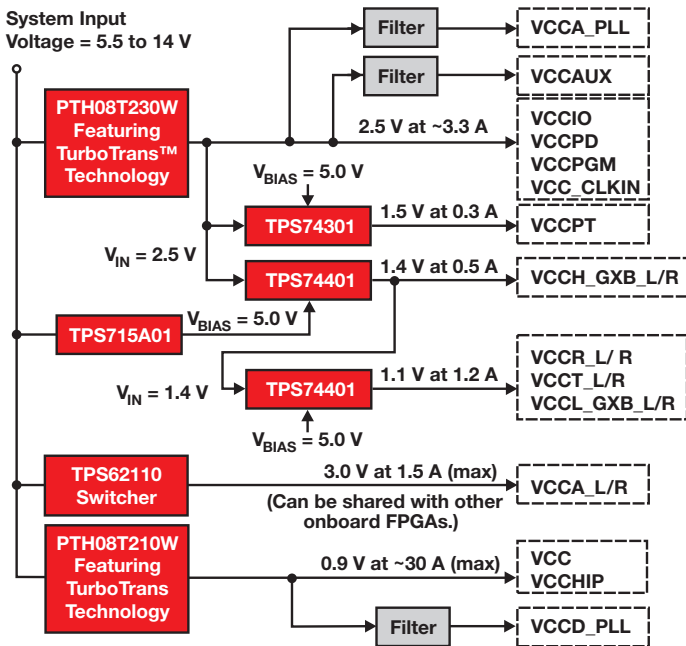

Power Distribution for Xilinx® Virtex®-6 and Spartan®-6 FPGAs

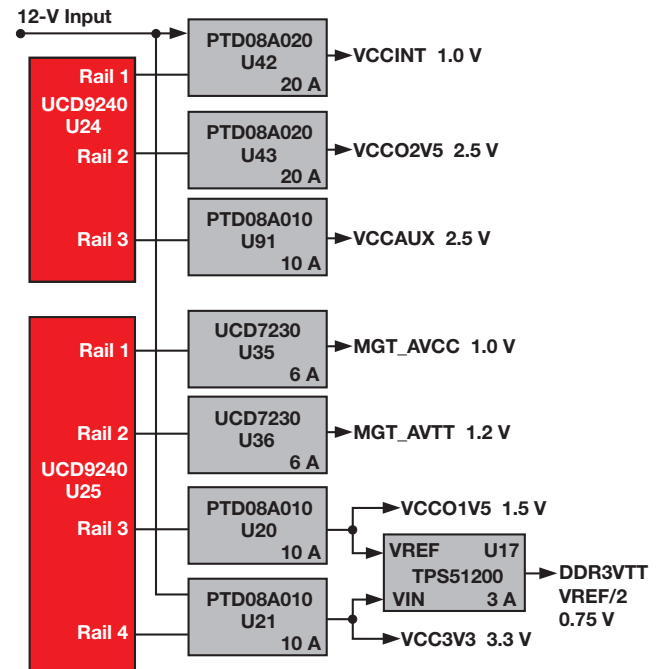

Space-Efficient TPS54620 6-A SWIFT™ Converter Powers Stratix IV Core Voltages

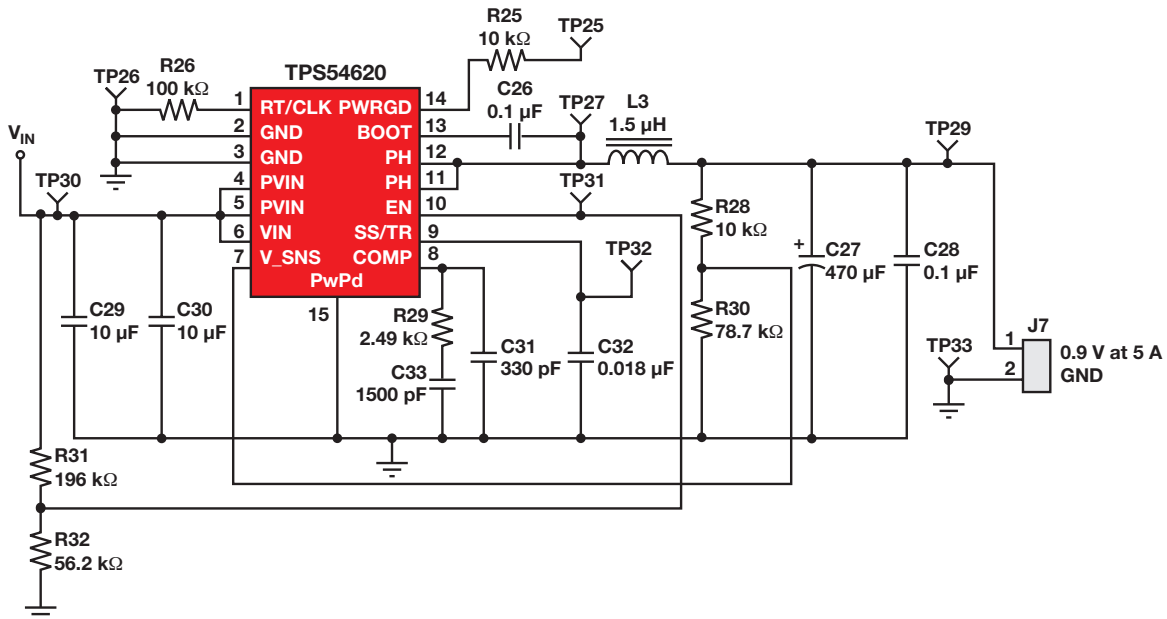



Active-Bus Termination Solutions (DDR/QDR/GTL/SSTL/HSTL)

TI offers a wide selection of active-bus termination solutions from LDOs and switching controllers to plug-in power. Typical application diagrams and product parameters are provided to aid product selection.

TPS54372: SWIFT™

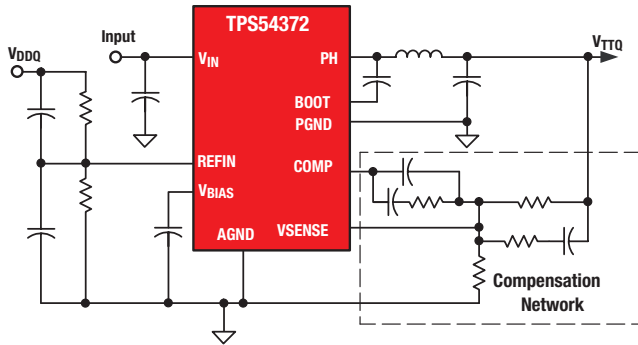

TPS51200: LDO

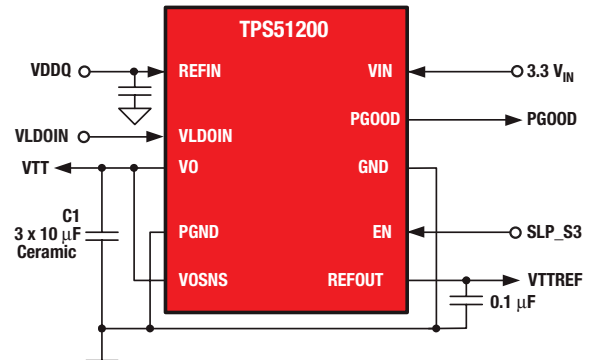

PTHxx060Y: Plug-In Power

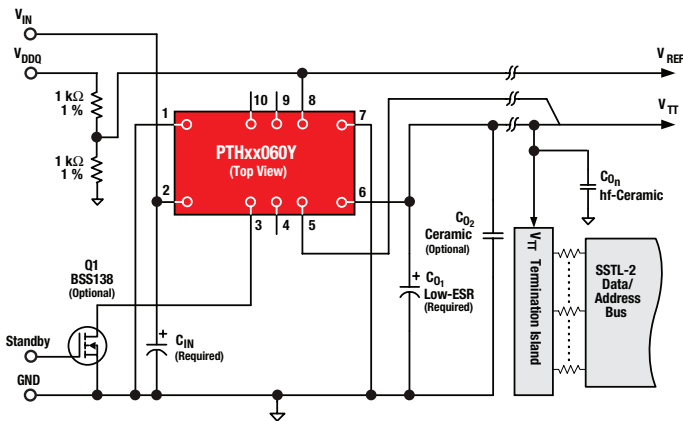

TPS51116: Controller + LDO

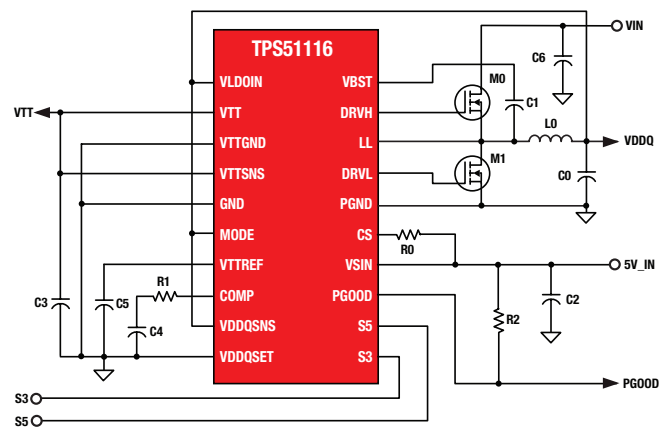

Selection Guide

Device	V _{IN} (V)	Topology	I _{OUT1} (V _{DDQ}) (A)	I _{OUT2} (V _{TT}) (A)	I _{OUT3} (Buf. V _{REF}) (mA)	V _{OUT1} (V _{DDQ}) (V)	V _{OUT2} (V _{TT}) (V)	V _{OUT3} (Buf. V _{REF}) (V)	DDR 1	DDR 2	DDR 3	Package(s)	Automotive Qualified†	Price*
Plug-In Power Modules														
PTH03010/50/60Y	2.95 to 3.65	Sync. Buck	—	15, 6, 10	—	—	0.55 to 1.8	—	✓	✓	✓	Module		11.60, 6.90, 9.80
PTH05010/50/60Y	4.5 to 5.5	Sync. Buck	—	15, 6, 10	—	—	0.55 to 1.8	—	✓	✓	✓	Module		11.60, 6.90, 9.80
PTH12010/50/60Y	10.8 to 13.2	Sync. Buck	—	15, 6, 8	—	—	0.55 to 1.8	—	✓	✓	✓	Module		11.60, 6.90, 9.80
Converters (with Integrated FETs)														
TPS54372	3.0 to 6.0	Sync. Buck	—	3	—	—	Adj. to 0.2	—	✓	✓	✓	20 HTSSOP	✓	2.25
TPS54672	3.0 to 6.0	Sync. Buck	—	6	—	—	Adj. to 0.2	—	✓	✓	✓	28 HTSSOP		3.20
TPS54872	4.0 to 6.0	Sync. Buck	—	8	—	—	Adj. to 0.2	—	✓	✓	✓	28 HTSSOP		3.65
TPS54972	3.0 to 4.0	Sync. Buck	—	9	—	—	Adj. to 0.2	—	✓	✓	✓	28 HTSSOP		3.80
Controllers (with External FETs)														
TPS40042	3.0 to 5.5	Sync. Buck	—	15	—	—	Adj. to 0.7	—	✓	✓	✓	10 SON		0.90
TPS40056	8 to 40	Sync. Buck	—	20	—	—	Adj. to 0.7	—	✓	✓	✓	16 HTSSOP		1.65
TPS51020	4.5 to 28	Dual Sync. Buck+ LDO	< 20	20	3	Adj. to 0.85	V _{DDQ} /2	V _{DDQ} /2	✓	✓		30 TSSOP		2.40
TPS51116	3.0 to 28 ¹	Sync. Buck+ LDO	< 10	+3/-3	—	Adj. to 1.5	V _{DDQ} /2	V _{DDQ} /2	✓	✓	✓	20 HTSSOP/ 24 QFN		1.80
Low Dropout Regulators														
TPS51100	1.2 to 3.6 ¹	LDO	—	+3/-3	10	—	V _{DDQ} /2	V _{DDQ} /2	✓	✓	✓	10 MSOP		0.80
TPS51200	1.1 to 3.5 ²	LDO	—	+2/-2	10	—	V _{DDQ} /2	V _{DDQ} /2	✓	✓	✓	10 SON	✓	0.90

¹Requires separate 4.75-V to 5.25-V bias supply.
[†]Automotive qualified devices have different pricing.

²Requires separate 2.4-V to 3.5-V bias supply.
^{*}Suggested resale price in U.S. dollars in quantities of 1,000.

New devices are listed in bold red.

Introduction

TI's family of Fusion Digital Power™ products focuses on two areas: Digital Power Controllers (UCD9K), complementary Power Stage solutions (UCD7K), and PTD-series modules. These products are power-management specific and are well-suited for applications where the desire exists for configurability, communications, diagnostics and adaptive control solutions. They include both isolated and non-isolated solutions from AC line to point-of-load, covering uninterruptible power supplies (UPS), server, telecom and datacom applications. The Digital Power ICs provide cost-effective solutions with greater levels of performance, reliability and flexibility than today's pure analog designs. For the most up-to-date information on digital power technology and product availability, go to:

www.ti.com/digitalpower

Key Benefits

- High levels of integration:
 - Multiple outputs and phases with one controller
 - Integrated supply-voltage sequencing, monitoring and margining
 - Improved reliability with fewer parts
- Advanced functionality:
 - Real-time power monitoring, data logging and failure prediction
 - Adaptive control for varying operation modes and load characteristics
 - Calibration in manufacturing
- System optimization:
 - Dead-band control for improved efficiency
 - Enhanced phase management

Digital Solution Features

- Supports PMBus™ Version 1.1
- Power + Designer Graphical User Interface tool
- Programmable soft-start/stop configuration
- Supports voltage sequencing and tracking
- Supports voltage margining and monitoring

- Supports pre-biased, monotonic start-up
- Multiple levels of fault protection with selectable response
- Hardware-accelerated digital compensator
- Supports load sharing on multiphase power stages
- Supports frequency synchronization
- Supports digital monitoring of power-supply parameters

UCD9K Buck Controllers Family

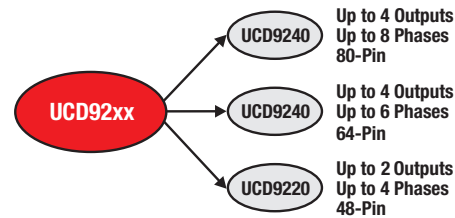

Digital Power Stage Solutions

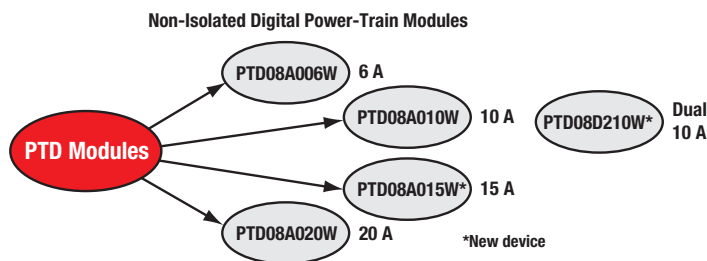
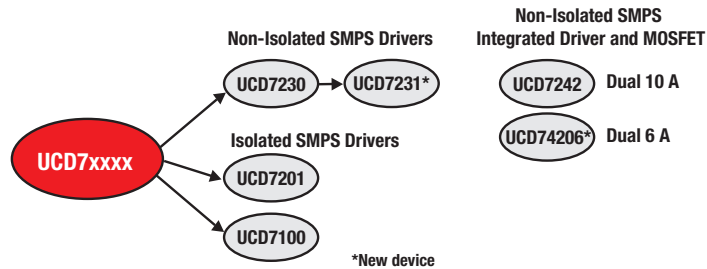

TMS320C2000™ Digital Signal Controllers

In addition to TI's UCDxxxx digital-power solutions, TI offers fully programmable C2000™ Digital Signal Controllers (DSC) for digital-power applications. C2000 DSCs are used in digital power systems like telecom rectifiers, non-isolated DC/DC converters, and green applications such as solar inverters and wind turbines. C2000 DSCs are optimized for real-time embedded control applications by integrating fast 12-bit ADCs and the most sophisticated PWM generation technology with a high-performance, 32-bit DSC CPU. The C2000 PWM allows duty-cycle modulation with 150-ps accuracy and the flexibility to support any power stage topology. TI has an extensive software library of common functions. For free download, visit: www.ti.com/dpslib

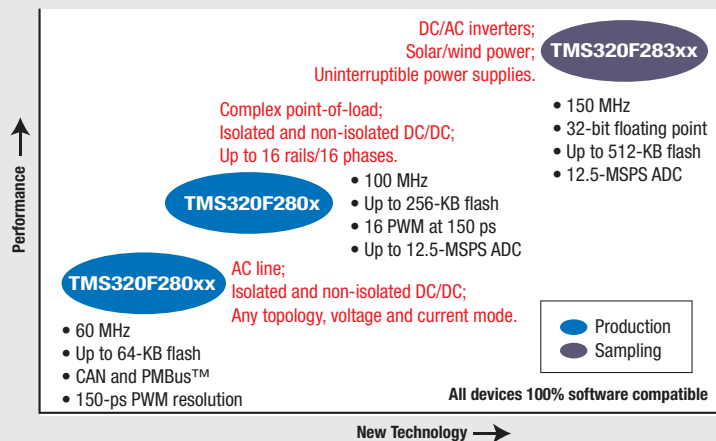

Digital Point-of-Load Controller UCD9240

Get samples and datasheets at: www.ti.com/sc/device/UCD9240

Key Features

- Controls up to 8 power stages and up to 4 voltage-feedback control loops
- Output voltage is configurable from 0.4 to 4.0 V
- Flexible configuration permits control of:
 - Four single or two dual power stages,
 - Two 4-phase power stages, or
 - One 2-, 4-, 6- or 8-phase power stage
- Supports switching frequencies of up to 2 MHz
- Supports conversion ratio of 12:1 at 2 MHz with 250-ps duty-cycle resolution
- ± 1 -mV feedback resolution
- Hardware-accelerated, digital 3-pole/3-zero compensator
- Can synchronize PWM clocks between multiple UCD9240 devices
- Enhanced nonvolatile memory with error-correction coding (ECC)

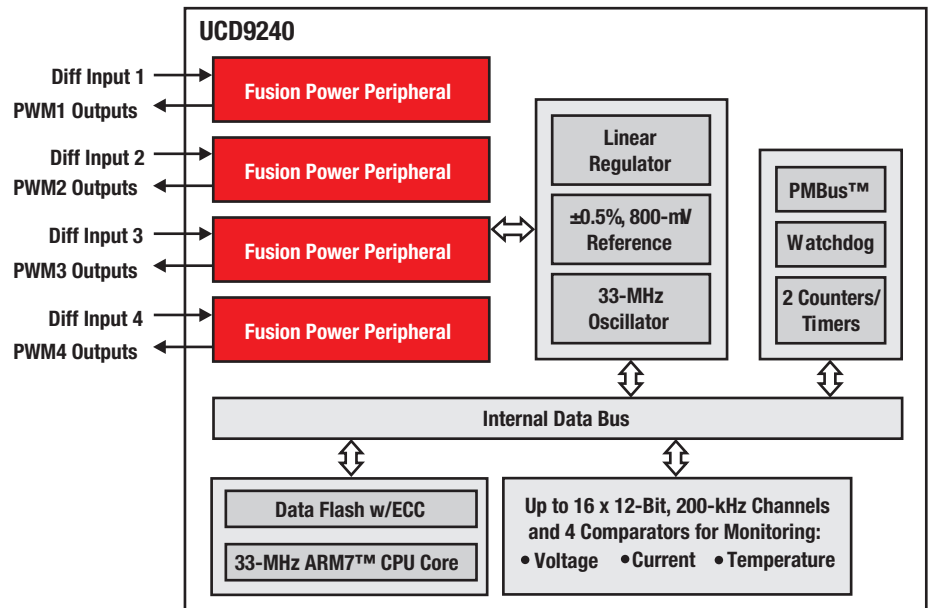

UCD9240 controller overview.

Fusion Digital Power™ Designer

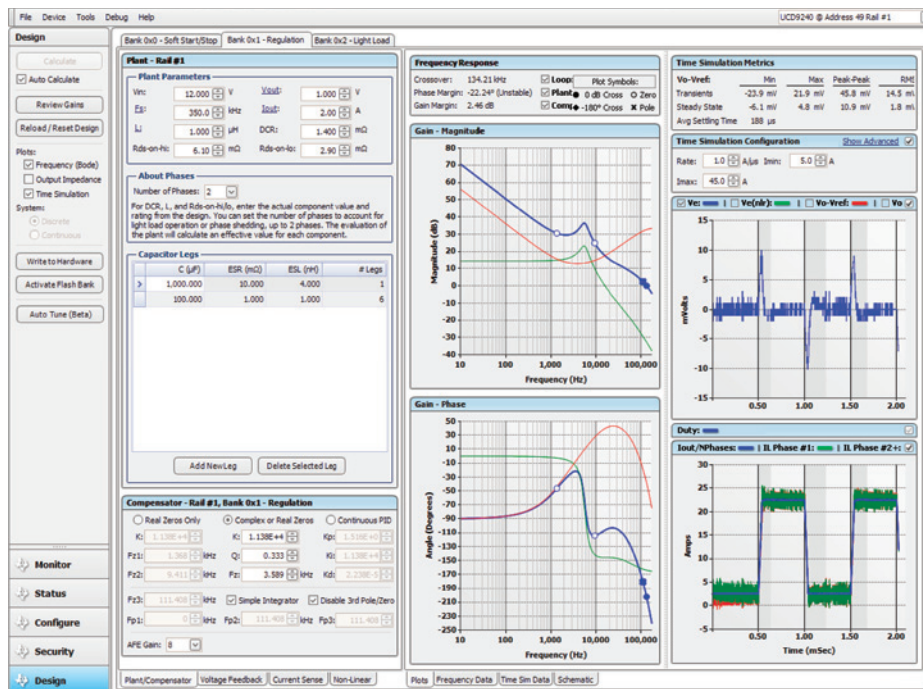

GUI Digital Power developer tool simplifies the design process.

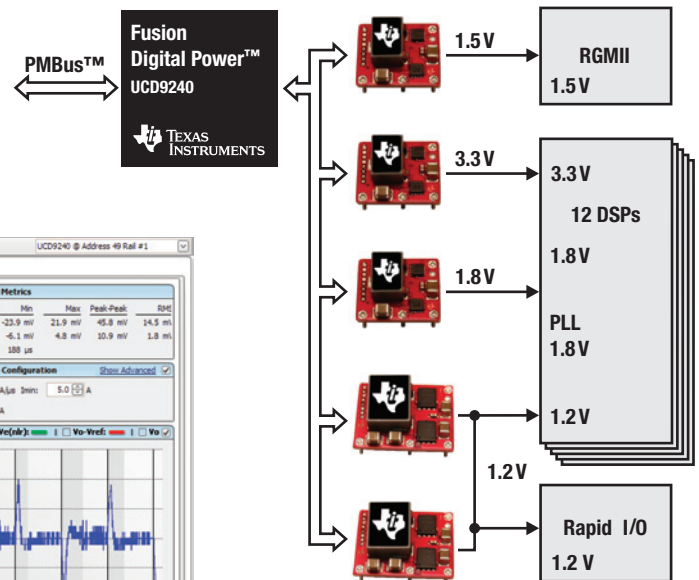

Multiprocessor, multiple-supply-rail systems (three single-phase outputs and one dual-phase output) featuring UCD9240 and first-generation PTD modules.

Digital Power

Dual 10-A Integrated Driver and MOSFETs

UCD7242

Key Features

Digital-power compatible features include:

- Accurate current sensing ($\pm 5\%$)
 - No inductor DCR sensing
 - No temperature compensation required
 - No calibration required
- Fault protection
 - Overcurrent
 - Overtemperature

- Analog temperature sense output
- Only 13 design components required to create two 10-A outputs

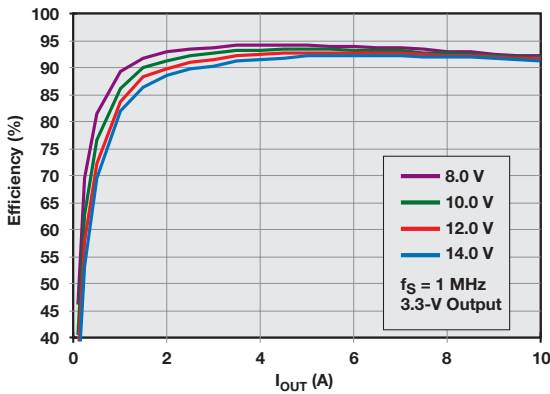
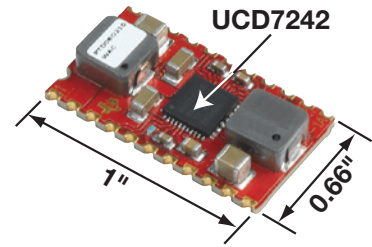

UCD7242 has high efficiency at high frequencies at 1 MHz.

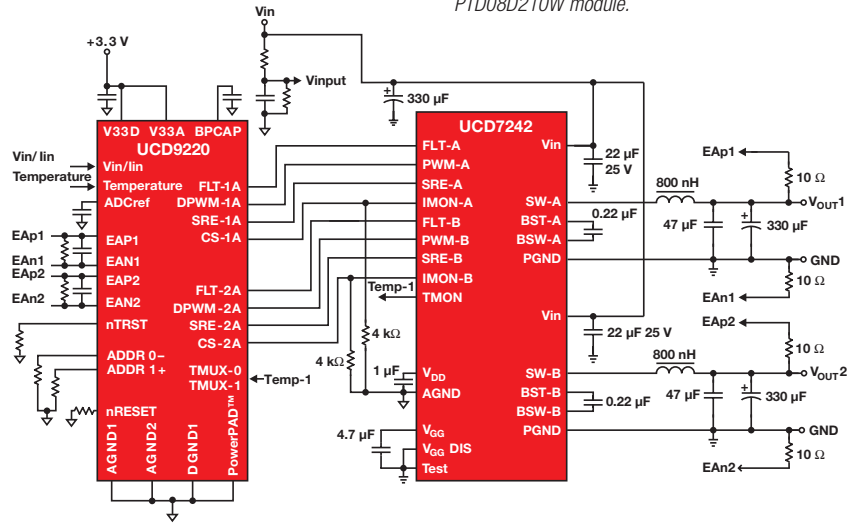

UCD7242 typical application.

Selection Guide

Device	Pin Count	Number of Outputs	Number of Phases	Maximum Fs (MHz)	PWM Resolution (ps)	Compensator	Nonvolatile Memory	Price*
Digital Point-of-Load Controllers								
UCD9240 ¹	80/64	4	8/6	2	250	3-pole/3-zero	Yes w/ECC	4.85/4.50
UCD9220	48	2	4	2	250	3-pole/3-zero	Yes w/ECC	2.65

Device	Number of Outputs	Output Configuration	Output Type ²	Peak I _{OUT} Source/Sink (A)	Rise/Fall Time (ns)	V _{CC} Range (V)	Propagation Delay (ns)	Input Threshold	Dead-Time Control	Protection Features	Price*
Digital Power MOSFET Drivers											
UCD7230	2	Non-inverting	CMOS	4/4	10/10	4.5 to 15.5	25	CMOS/TTL	Adaptive	Adjustable	0.60
UCD7231	2	Non-inverting	CMOS	6/6	10/10	4.5 to 15.5	25	CMOS/TTL	Adaptive	Adjustable	0.60
UCD7100	1	Uncommitted/Non-inverting	TrueDrive™	4/4	10/10	4.5 to 16	20	CMOS/TTL	Adaptive	Adjustable	0.99
UCD7201	2	Uncommitted/Non-inverting	TrueDrive	4/4	10/10	4.5 to 16	20	CMOS/TTL	Adaptive	Adjustable	1.20

¹ The UCD9240 has two orderable part numbers: UCD9240PFC and UCD9240RGC. The PFC suffix controls four outputs and up to eight phases.

New devices are listed in bold red.

The RGC suffix controls four outputs and up to six phases.

² Output type: TrueDrive is the hybrid bipolar/CMOS output architecture for improved current drive capability at low voltages (at Miller threshold).

*Suggested resale price in U.S. dollars in quantities of 1,000.

Device	Input Voltage (V)	Output Configuration	Current Rating (A)	Price*
Digital Power Integrated Driver/MOSFET				
UCD7242	4.5 to 18	Dual	10/10	2.65
UCD74206	4.5 to 18	Dual	6/6	2.25

*Suggested resale price in U.S. dollars in quantities of 1,000.

Device	Input Voltage (V)	Output Configuration	Current Rating (A)	Price*
Digital Power-Train Modules				
PTD08A006W	4.75 to 14	Single	6	6.90
PTD08A010W	4.75 to 14	Single	10	8.50
PTD08A015W	4.75 to 14	Single	15	9.80
PTD08A020W	4.75 to 14	Single	20	12.90
PTD08D210W	4.5 to 18	Dual	10/10	12.00

New devices are listed in bold red. Preview devices are listed in bold blue.

Power Factor Correction (PFC)

Design Factors

Control Method

Average-Current Mode (ACM) — Optimum control method to achieve PFC and low harmonic distortion.

Transition Mode (TM) — Simpler, inexpensive control with high peak currents and filtering requirements.

Interleaved — TM- and ACM-compatible multiphase, high-power, high-density topology. Delivers better EMI, smaller magnetics and reduced ripple currents.

Zero-Voltage-Transition (ZVT) Mode

— A type of soft-switching technique, which reduces EMI and allows for higher frequency operations.

Protection

- Overvoltage protection (OVP) prevents output capacitor, switches and load from overcharge condition.

- Soft-start (programmable) provides controlled start-up.
- Overcurrent protection (OCP) provides protection during overload conditions.

Performance

- Voltage feed-forward for linearized performance and faster transient response over wide line voltage range.
- Multiplier linearity and zero power detect functions improve light load operation.
- Onboard high output current drive capability without external MOSFET drivers.

Flexibility

- Ability to work with a wide line voltage range.
- Different levels of undervoltage lockout thresholds for self bias and auxiliary bias applications.
- Ability to synchronize controllers to eliminate noise issues.

Power Level

- IEC requirements are applicable to all power supplies above 75 W.
- Higher power converters may require zero-current-switching (ZCS) and ZVT-switching techniques to achieve high efficiencies.
- Some of the simpler control techniques not usable at high power levels.

Features

- From 50 W to 5 kW, TI PFC controllers deliver EN61000-3-2 compliance.
- Industry standard architecture.
- Deliver PF > 0.993.
- New BiCMOS generation reduces complexity.
- Optimized PFC/PWM “combo” controllers.
- Superior applications support.

Interleaved PFC

Interleaved PFC is gaining popularity in external and embedded-type power-supply architectures. It is exceptionally flexible and provides many cost-saving features such as passive-component size reductions, smaller EMI filtering components and higher efficiencies. TI offers both Transition Mode (UCC28060) and Continuous Conduction Mode (CCM) (UCC28070) control methods.

Other benefits of interleaving include scalability and ultrathin designs. Scalability allows for addressing many different power levels and applications.

www.ti.com/sc/device/UCC28060

www.ti.com/sc/device/UCC28061

www.ti.com/sc/device/UCC28070

Why Interleave?

- Lower system cost from ripple-current cancellation
- Enables ultraslim and high-density designs
- Lower total inductor volume
- Smaller or lower-cost EMI filter and output capacitors
- Facilitates higher efficiency

Applications

- Digital TV
- Telecom power supplies and rectifiers
- Professional and consumer audio
- Merchant power supplies
- Air conditioning and refrigeration compressors
- Variable-speed motors
- Low-profile power-supply applications

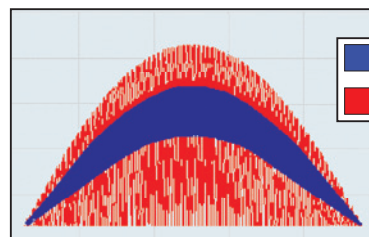
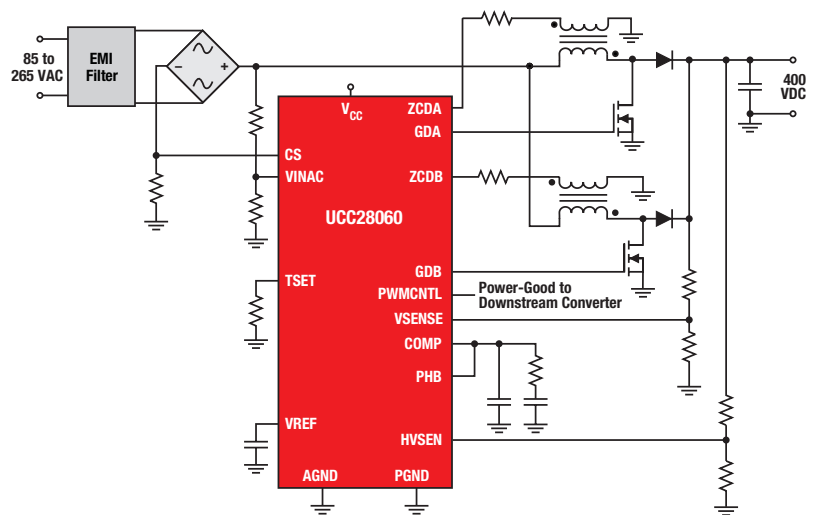

UCC28060 Transition Mode PFC with Natural Interleaving™ technique.

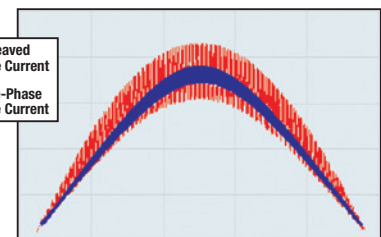

UCC28070 Continuous Conduction Mode PFC.

→ Power Factor Correction (PFC)

Selection Guide

Device	Description	Control Method ¹	Typical Power Level	Soft Switching ²	Max Frequency (kHz)	Start-Up Current (mA)	UVLO Thresholds (V)	PWM Prog. Max Duty Cycle	PWM Freq. Option	OVP	Price*
UCC28060	Natural Interleaving™ Transition Mode Controller for 80+™ and Energy Star™ Solutions	TM	100 W to 1 kW	—	Variable	5	12.6/10.35	—	—	✓	1.40
UCC28070	Continuous Conduction Mode Controller for High-Performance Applications	ACM	500 W to 2 kW+	—	300	8	10.2/9.2	—	—	✓	1.95
UCC28061	Natural Interleaving Transition Mode Controller for 80+ and Energy Star Solutions	TM	100 W to 1 kW	—	Variable	5	12.6/10.35	—	—	✓	1.40
UCC28019A	8-Pin PFC Controller	ACM	75 W to 600 W	—	65	0.01	10.5/9.5	—	—	—	0.80
UC3852	Transition Mode PFC Controller	TM	<150 W	—	Variable	1	16.3/11.5	—	—	—	1.70
UC3853/A	8-Pin PFC Controller	ACM	75 W to 300 W	—	125	0.25	11.5/9.5	—	—	✓	0.99
UC3854	PFC Controller	ACM	200 W to 2 kW+	—	200	1.5	16/10	—	—	—	1.15
UC3854A/B	Improved PFC Controller	ACM	200 W to 2 kW+	—	200	0.3	16/10 ('3854A), 10.5/10 ('3854B)	—	—	—	1.35
UC3855A/B	High Performance Soft Switching PFC Controller	ACM	400 W to 2 kW+	ZVT	500	0.15	16/10 ('3855A), 10.5/10 ('3855B)	—	—	✓	5.70
UCC38050/1	Transition Mode PFC Controller	TM	50 W to 400 W	—	Variable	0.75	15.8/9.7 ('38050), 12.5/9.7 ('38051)	—	—	✓	0.70
UCC3817A/8A	BiCMOS PFC Controller	ACM	75 W to 2 kW+	—	400	0.1	16/10 ('3817A), 10.5/10 ('3818A)	—	—	✓	1.15
UCC3819A	Tracking Boost PFC Controller	ACM	75 W to 2 kW+	—	400	0.1	10.2/9.7	—	—	✓	1.15
UCC38500/1/2/3	PFC+PWM Combo Controller	ACM	75 W to 1 kW+	—	400	0.1	16/10 ('38500/2), 10.5/10 ('38501/3)	—	1x	✓	2.35
UCC28510/1/2/3	Advanced PFC+PWM Combo Controller	ACM	75 W to 1 kW+	—	600	0.1	16.6/9.3 ('28510/2), 10.2/9.7 ('28511/3)	✓ ³	1x	✓	1.80
UCC28514/5/6/7	Advanced PFC+PWM Combo Controller	ACM	75 W to 1 kW+	—	600	0.1	16.6/9.3 ('28514/6), 10.2/9.7 ('28515/7)	✓ ³	2x	✓	1.80
UCC28521/8	Advanced PWM/PFC Combo Controller with TEM/TEM Modulation	ACM	75 W to 1 kW+	—	600	0.1	10.2/9.7	✓ ³	2x	✓	1.80

¹ACM = average current mode; TM = transition mode.

²ZVT = zero voltage transition.

³Up to 90%.

New devices are listed in bold red.

*Suggested resale price in U.S. dollars in quantities of 1,000.

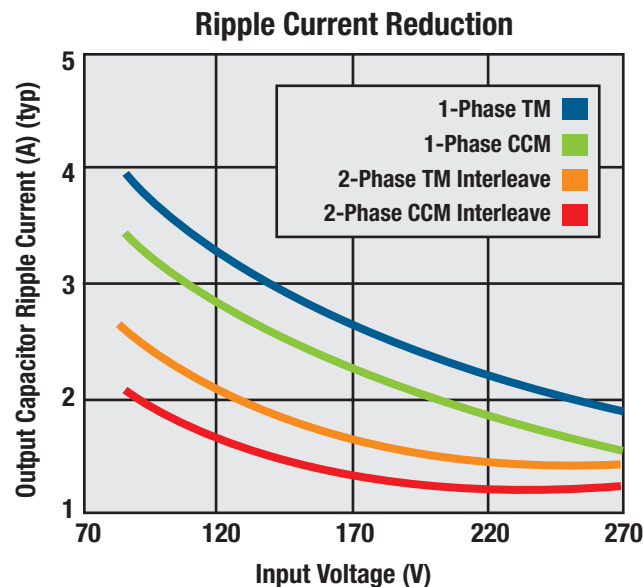

Interleaved PFC reduces ripple current in the output capacitor.

For a complete list of Resources, visit: power.ti.com

PWM Power Supply Controllers



Single-Ended Topologies

Control Method

Voltage Mode — Simple, low-noise control method for wide input and output range requirements.

Current Mode — Fast transient response with built-in current limiting.

Level of Integration

- Integrated soft-start (programmable) provides predictable start-up.
- Internal leading edge blanking to suppress switching spike from MOSFET turn-on.

Performance

- Many voltage mode controllers have input voltage feedforward for instantaneous response to input line changes.
- Most controllers have onboard high current drive capability without external MOSFET drivers.

- Lower start-up current for offline applications (for BiCMOS products with UCC prefix).
- Low operating current (for BiCMOS products with UCC prefix) for light-load efficiency.
- Programmable minimum duty cycle clamp for light-load efficiency (UCC3581).

Features

- 10-W to 350-W offline and DC/DC power supplies.
- Single-ended topology power supplies, buck, boost, flyback and forward.

Double-Ended Topologies

Current Mode — Control technique featuring fast transient response with inherent cycle-by-cycle current limiting.

Voltage Mode — Versatile, low-noise control method for wide duty cycle ranges.

Soft Switching

- Zero Voltage Transition (ZVT) soft switching techniques minimize power loss at turn-on.
- Phase shifted, ZVT controllers maximize efficiency in full-bridge converters.

Protection

- Flexible overcurrent limiting circuitry provides programmable fault protection modes.
- Programmable soft-start executes predictable start-up on initialization and after faults.
- High speed, cycle-by-cycle current limiting.
- Maximum duty cycle clamp to prevent transformer saturation.
- Programmable deadtime control to prevent cross conduction of power switches.

Low- to Medium-Power PWM Controllers (25 W to 350 W)

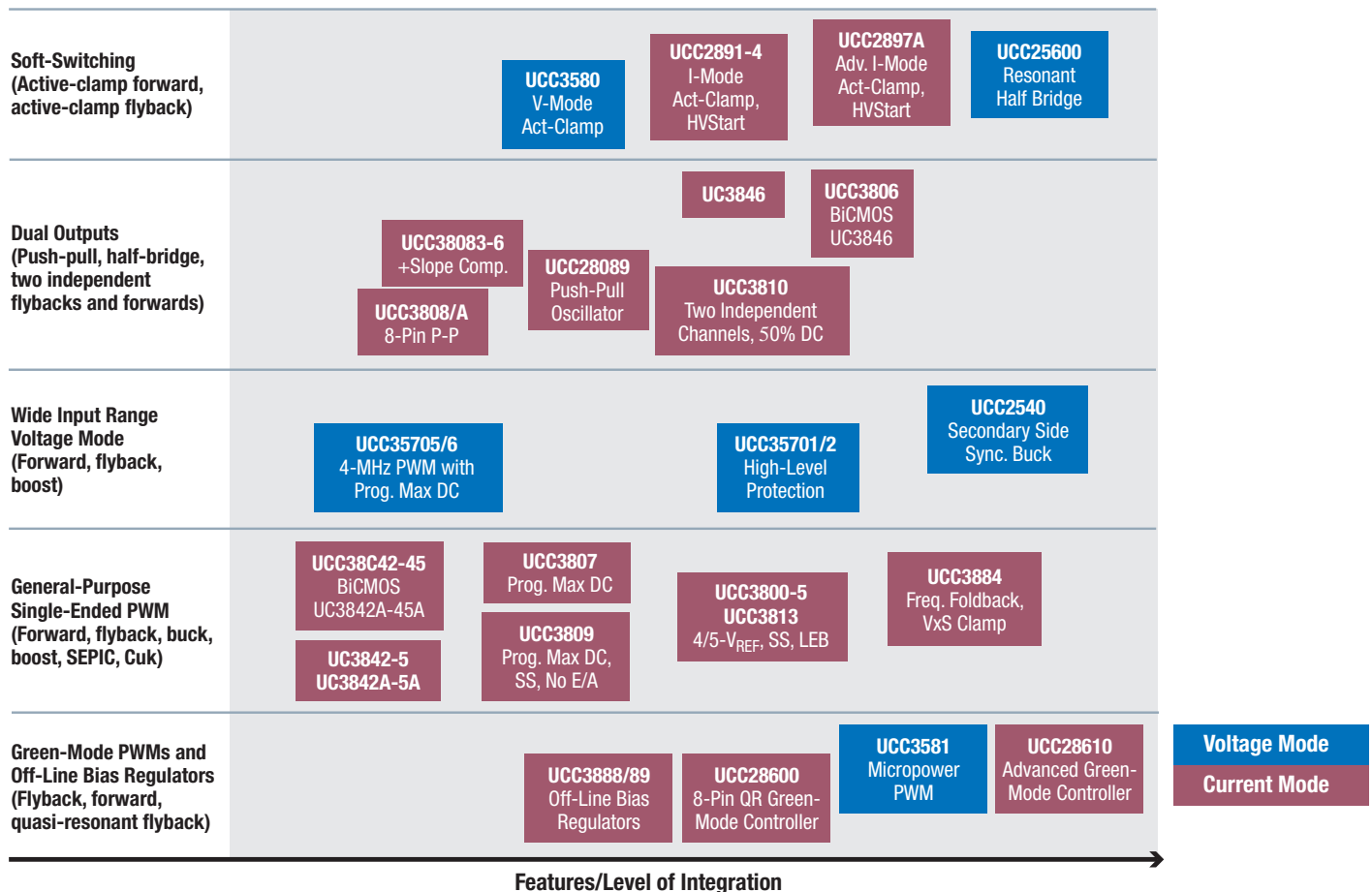

→ PWM Power Supply Controllers

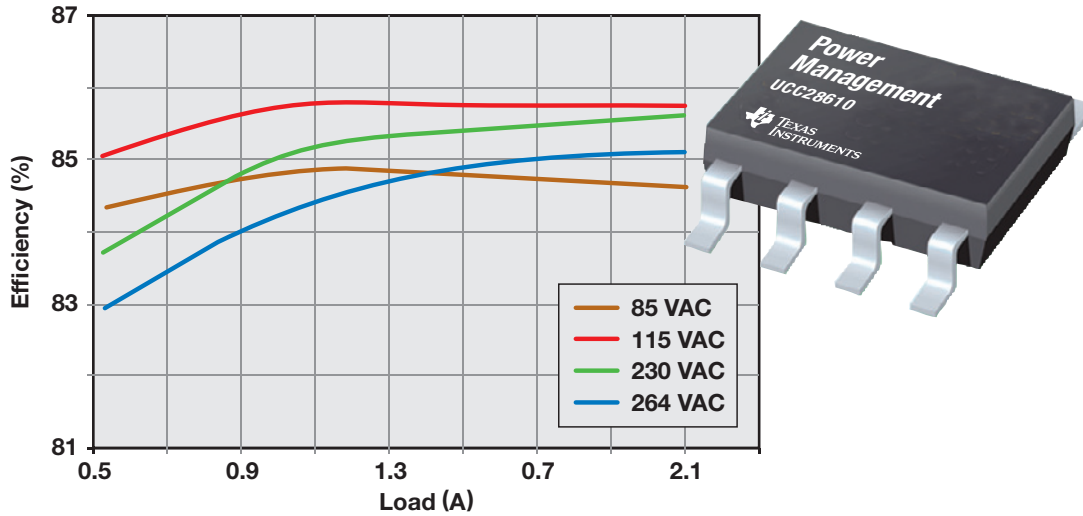

Quasi-resonant flyback using the UCC28610 achieves high efficiency and a cost-effective design.

Medium- to High-Power PWM Controllers (>300 W)

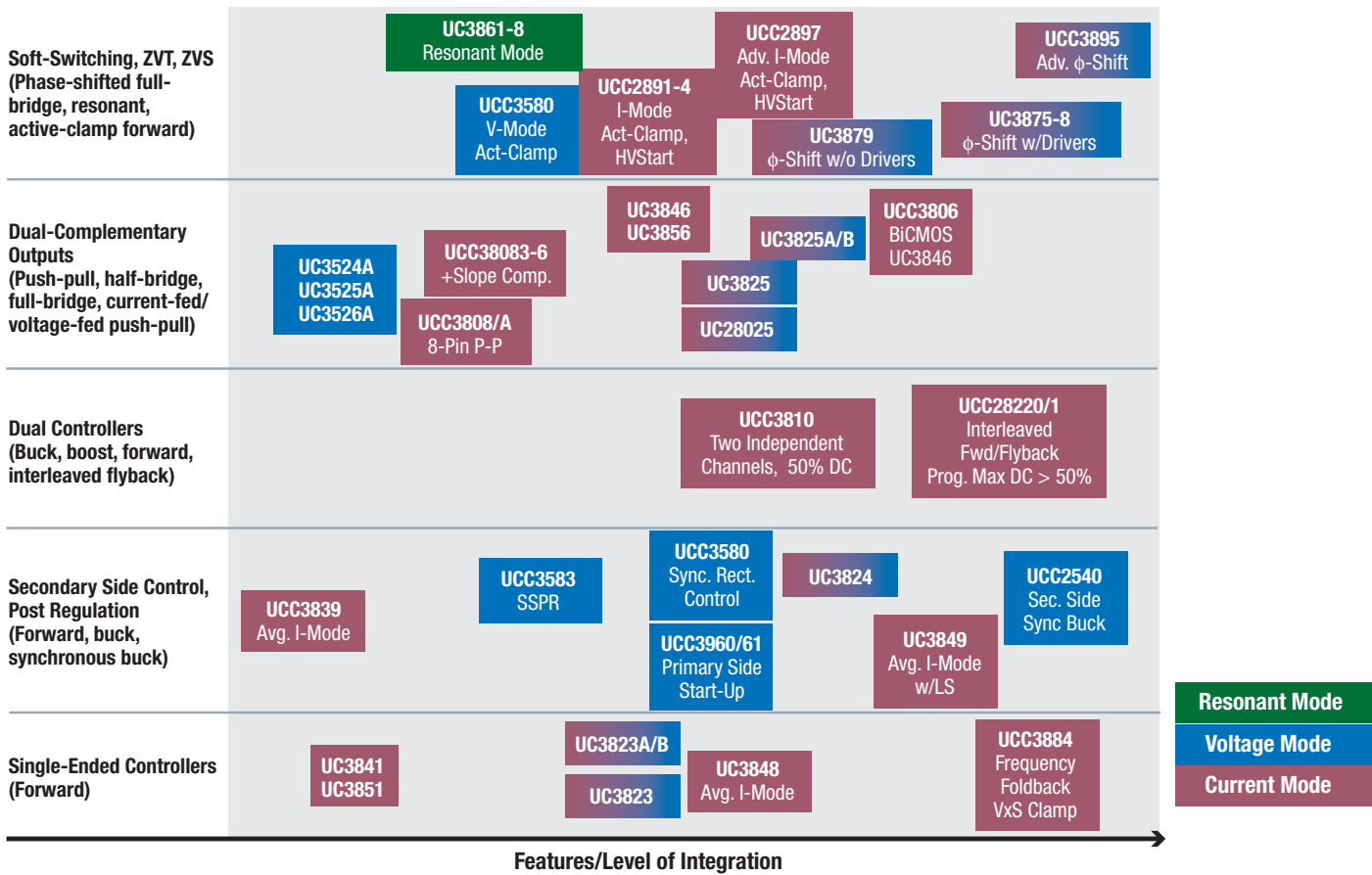

For a complete list of Resources, visit: power.ti.com



High-Performance Resonant-Mode Controller

UCC25600

Get samples, datasheets and app reports at: www.ti.com/sc/device/UCC25600

The UCC25600 high-performance resonant-mode controller is designed for AC/DC and DC/DC applications utilizing resonant topologies, especially the LLC half-bridge resonant converter.

This highly integrated 8-pin controller implements frequency-modulation control and complete system functions that simplify design. It has an innovative bounded operating frequency range that can reduce total system costs by up to 20%.

Key Features

- Variable switching frequency control
- Programmable minimum switching frequency
- Programmable dead time for best efficiency
- Programmable soft-start
- Easy ON/OFF control
- Overcurrent and overtemp protection
- Bias voltage UVLO and OVP, integrated gate

- Driver with 0.4-A source and 0.8-A sink capability
- Extended temperature range: -40°C to 125°C
- SOIC 8-pin package

Applications

- Power supplies up to 1 kW
- Digital TVs
- Consumer electronics
- Gaming adaptors

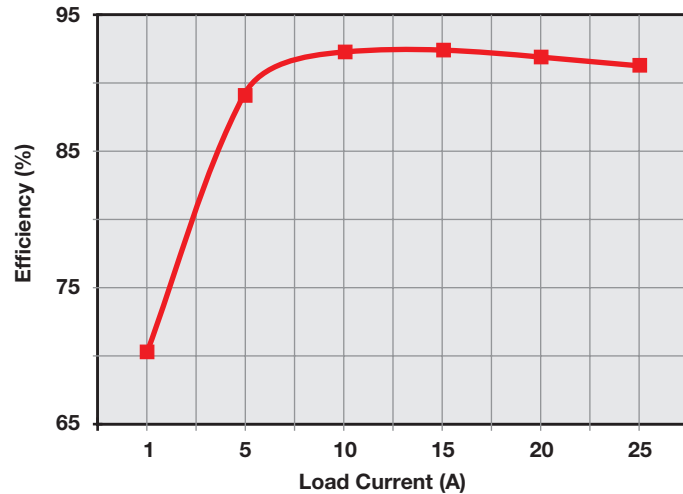

Typical UCC28230 efficiency plot.

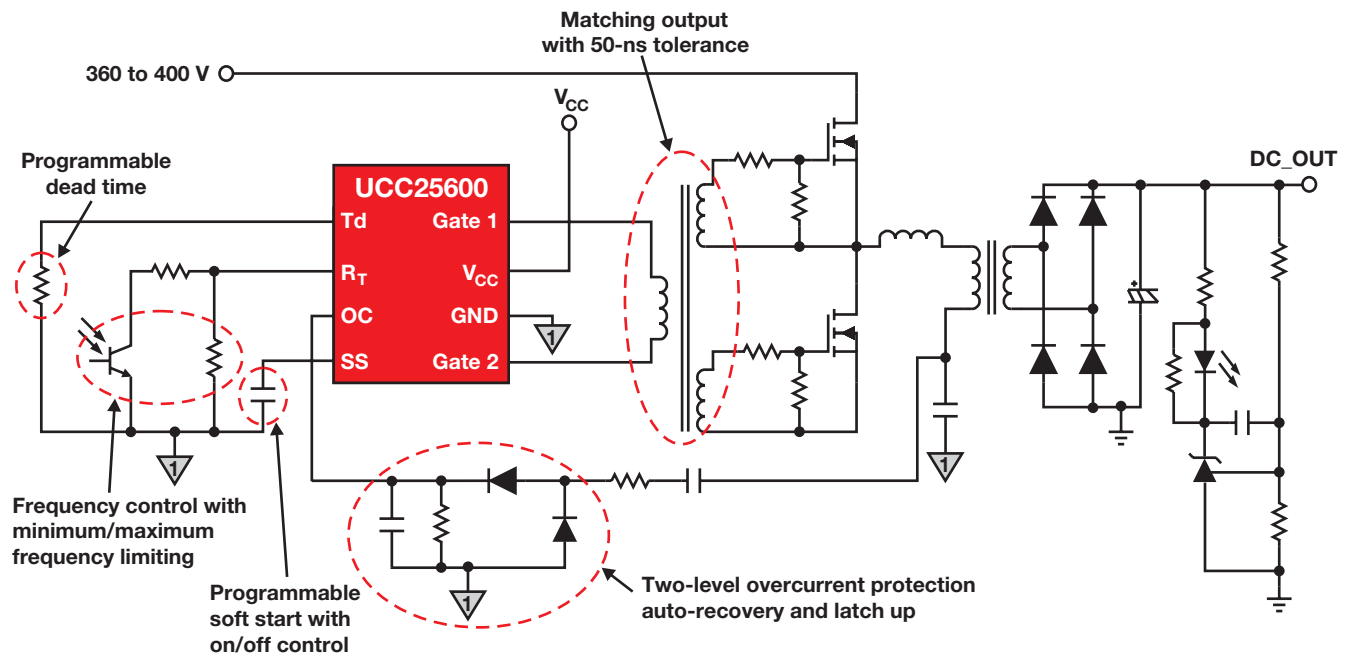

Typical application using UCC28230.

 PWM Power Supply Controllers

Selection Guide

(Device parameters continued on next page)

Device	Typical Power Level (W)	Control Method			Topologies										Maximum Practical Frequency	Start-Up Current	Operating Current	Supply Voltage (V)	110-V Start-Up Circuit	UVLO: On/Off (V)		
		Voltage Mode	Current Mode	Avg. Current Mode	Buck	Boost	Flyback (SEPIC, Cuk)	Fwd (Including 2-Switch Fwd)	Forward (D > 50%)	Interleaved Fwd/Flyback/Boost	Act-Clamp Fwd/Flyback	Push-Pull	I-Fed/V-Fed Push-Pull	Half-Bridge							Full-Bridge	ϕ-Shifted FB
Green Mode Controllers and Offline Bias Regulators																						
UCC28610	10 to 40		✓		✓		✓										140 kHz	10 µA	3.7 mA	9 to 20	—	10.7/7.55
UCC28600	50 to 150		✓				✓										130 kHz	25 µA	50 mA	30	—	13/8
UCC3888/89	<10	✓					✓										250 kHz	150 µA	1.2 mA	9	—	8.4/6.3
Intermediate Bus Controllers																						
UCC28230/1	150 to 500																2 MHz	150 µA	3 mA	−0.3 to 20	—	6.6 to 6
General-Purpose Single-Ended Controllers																						
TL3842B/3B/4B/5B	30 to 350	✓	✓		✓	✓	✓	✓									500 kHz	0.3 mA	11 mA	10 to 30	—	16/10
UC28023	50 to 750	✓	✓		✓	✓	✓	✓									1 MHz	1.1 mA	22 mA	9 to 30	—	9.2/8.4
UC3823	50 to 750	✓	✓		✓	✓	✓	✓									1 MHz	1.1 mA	22 mA	9 to 30	—	9.2/8.4
UC3823A/B	50 to 750	✓	✓		✓	✓	✓	✓									1 MHz	100 µA	28 mA	9 to 22	—	9.2/8.4/16/10
UC3842A/3A/4A/5A	30 to 350	✓	✓		✓	✓	✓	✓									500 kHz	0.5/0.3 mA	11 mA	10 to 30	—	4 Options
UCC3800/1/2/3/4/5	10 to 200	✓	✓		✓	✓	✓	✓	✓								1 MHz	100 µA	500 µA	4.1 to 15	—	5 Options
UCC3807-1-2-3	10 to 200	✓	✓		✓	✓	✓	✓									1 MHz	100 µA	1.3 mA	6.9 to 15	—	3 Options
UCC3809-1-2	10 to 200	✓	✓		✓	✓	✓	✓									1 MHz	50 µA	500 µA	8 to 19	—	2 Options
UCC3813-0/1/2/3/4/5	10 to 200	✓	✓		✓	✓	✓	✓	✓ ¹	✓ ¹							1 MHz	100 µA	500 µA	7.2 to 151	—	5 Options
UCC3884	50 to 250	✓	✓		✓	✓	✓	✓									1 MHz	200 µA	5 mA	8.9 to 15	—	8.9/8.3
UCC38C40/1/2/3/4/5	10 to 250	✓	✓		✓	✓	✓	✓									1 MHz	50 µA	2.3 mA	5 Options	—	5 Options
Wide-Input Range Voltage Mode Controllers																						
UCC35701/2	25 to 250	✓					✓	✓	✓								700 kHz	130 µA	750 µA	8.8 to 15	—	2 Options
UCC35705/6	25 to 250	✓					✓	✓	✓	✓							4 MHz	50 µA	2.5 mA	8.0 to 15	—	2 Options
Dual Output Controllers																						
TL494 or TL594	50 to 500	✓			✓	✓	✓	✓	✓	✓	✓	✓	✓	✓	✓	✓	300 kHz	—	7.5 mA	7 to 40	—	—
TL598	50 to 500	✓			✓	✓	✓	✓	✓	✓	✓	✓	✓	✓	✓	✓	300 kHz	—	15 mA	7 to 40	—	6.1/6
UC28025	50 to 750	✓	✓														1 MHz	1.1 mA	22 mA	9 to 30	—	9.2/8.4
UC3524A	50 to 500	✓															250 kHz	4 mA	5 mA	8 to 40	—	7.5/7
UC3525B - UCC3526A	50 to 500	✓															250 kHz	—	14 mA	8 to 40	—	7/7
UC3824	50 to 250	✓	✓														1 MHz	1.1 mA	22 mA	9 to 30	—	9.2/8.4
UC3825	50 to 750	✓	✓														1 MHz	1.1 mA	22 mA	9 to 30	—	9.2/8.4
UC3825A/B	50 to 750	✓	✓														1 MHz	100 µA	28 mA	9 to 22	—	16/10/9.2/8.4
UC3827-1/-2	50 to 500	✓	✓														450 kHz	1000 µA	32 mA	8.4 to 20	—	9/8.4
UC3846/56	50 to 750	✓	✓														1 MHz	1.5 mA	17 mA	8 to 40	—	7.7/7
UCC28089	25 to 250																500 kHz	130 µA	1.4 mA	8 to 15	—	10.5/8
UCC28220/1	50 to 800		✓														1 MHz/ch.	200 µA	3 mA	8 to 14.5	✓	2 Options
UCC3806	50 to 750	✓	✓														350 kHz	100 µA	1.4 mA	7 to 15	—	7.5/6.7
UCC3808-1/-2/A-1/A-2	50 to 500		✓														1 MHz	130 µA	1 mA	4.3 to 15	—	12.5/8.3/4.3/4.1
UCC38083/4/5/6	50 to 500		✓														1 MHz	130 µA	20 mA	8.3 to 15	—	12.5/8.3
UCC3810	50 to 500	✓	✓		✓	✓	✓	✓	✓								1 MHz	150 µA	2 mA	8.3 to 11	—	11.3/8.3
Soft-Switching, ZVT and ZVS Controllers																						
UCC25600	200 W to 1 kW																350 kHz	100 µA	7.5 mA	11.5 to 18	—	11.1/8.9
UC3875/6/7	200 W to 2 kW	✓	✓	✓													1+ MHz	150 µA	45 mA	10.7 to 20	—	10.7/9.3/15/9
UC3879	200 W to 2 kW	✓	✓														500 kHz	150 µA	27 mA	11 to 20	—	15.2/9/10.7/9
UCC2891/3	75 to 600		✓														1 MHz	300 µA	2 mA	8.5 to 14.5	✓	13/8
UCC2892/4	75 to 600		✓														1 MHz	300 µA	2 mA	8.5 to 14.5	—	13/8
UCC2897A	75 to 600		✓														1 MHz	300 µA	2 mA	8.5 to 14.5	✓	13/8
UCC3580-1/-2/-3/-4	50 to 500	✓															500 kHz	100 µA	1.5 mA	7 to 15	—	15/8.5/9.8/5
UCC3895	200 W to 2 kW	✓	✓	✓													1 MHz	150 µA	5 mA	11 to 17	—	11/9
Secondary-Side, Post Regulation																						
UCC3583	50 to 500																500 kHz	100 µA	3 mA	8.5 to 15	—	9/8.4

¹Value varies by part number suffix. Please check datasheet.

New devices are listed in bold red.

Note: UC2xxx and UCC2xxx devices are extended temperature-range versions of the UC3xxx and UCC3xxx devices.

PWM Power Supply Controllers



(Device parameters continued from previous page)

Device	V _{REF} (V)	V _{REF} Tol. (%)	Max Duty Cycle (%)	Soft Start	E/A	Shut-down Pin	Voltage Feed-forward	Output Drive (Sink/Source) (A)	Slope Comp	Sync Pin	Leading Edge Blanking	Package(s)							Price*	
												MSOP	SON	SSOP	TSSOP	HTSSOP-PowerPAD™	SOIC	SOIC-W (300 mil)		SOIC-W Power
Green Mode Controllers and Offline Bias Regulators																				
UCC28610	—	—	—	—	—	—	—	—	—	—	—				8				0.60	
UCC28600	—	—	99	✓	—	—	—	1/0.75	—	—	—				8				0.49	
UCC3888/89	2.5	3	5.5	✓	—	—	✓	0.2/0.15	—	—	—				8		8		0.59	
Intermediate Bus Controllers																				
UCC28230/1	5 or 3.3	1.5	99	✓	—	—	—	0.2/0.2	—	—	—		12	14					1.20	
General-Purpose Single-Ended Controllers																				
TL3842B/3B/4B/5B	5	2	100	—	✓	—	—	1/1	—	—	—				8/14		8		0.54	
UC28023	5.1	1	Prog.	✓	✓	—	—	1.5/1.5	—	✓	—					16	16		1.35	
UC3823	5.1	1	Prog.	✓	✓	—	—	1.5/1.5	—	✓	—					16	20	16	1.60	
UC3823A/B	5.1	1	Prog.	✓	✓	—	—	2/2	—	✓	—					16	20	16	4.90	
UC3842A/3A/4A/5A	5	1.5	50 or 100	—	✓	—	—	1/1	—	—	—			8/14			8	H	0.80	
UCC3800/1/2/3/4/5	5	1.5	100	✓	✓	—	—	1/1	—	—	100 ns		8	8			8		1.35	
UCC3807-1-2-3	2 (Int)	—	Prog.	✓	✓	—	—	1/1	—	—	100 ns						8		1.50	
UCC3809-1-2	5	5	90	✓	—	✓	—	0.8/0.4	—	—	—	8		8			8		0.85	
UCC3813-0/1/2/3/4/5	5 ¹	2	50 or 100	✓	✓	—	—	1/1	—	—	100 ns		8	8			8		0.80	
UCC3884	5	2.5	100	✓	✓	—	—	1/0.5	—	—	—						16		1.60	
UCC38C40/1/2/3/4/5	5	2	100	—	✓	—	—	1/1	—	—	—	8					8		0.95	
Wide-Input Range Voltage Mode Controllers																				
UCC35701/2	5	1.5	VS Clamp	✓	—	✓	✓	1.2/1.2	—	✓	—			14	14			14	2.95	
UCC35705/6	—	—	93	—	—	—	✓	0.1/0.1	—	—	—	8			8			8	0.75	
Dual Output Controllers																				
TL494 or TL594	5	5	45	—	✓	—	—	0.2/0.2	—	✓	—			16	16			16	H	0.23
TL598	5	1	45	—	✓	—	—	0.2/0.2	—	✓	—				16			16	H	0.81
UC28025	5.1	1	Prog.	✓	✓	—	—	1.5/1.5	—	✓	—				16			16		1.35
UC3524A	5	2	Prog.	✓	✓	✓	—	0.2/0.2	—	✓	—				16			16		1.70
UC3525B - UCC3526A	5	2	Prog.	✓	✓	✓	—	0.2/0.2	—	✓	—				16		20	16	1.05	
UC3824	5.1	1	Prog.	✓	✓	—	—	1.5/1.5	—	✓	—					16		16		4.55
UC3825	5.1	1	Prog.	✓	✓	—	—	1.5/1.5	—	✓	—					16	20	16	H	1.60
UC3825A/B	5.1	1.5	Prog.	✓	✓	—	—	2/2	—	✓	—					16	20	16		2.65
UC3827-1/-2	5	4	—	✓	✓	—	—	1/0.8	—	✓	—					24	28	24		3.50
UC3846/56	5	2	Prog.	✓	✓	—	—	0.5/0.5	—	✓	—					16	20	16	H	1.60
UCC28089	—	—	50	✓	—	—	—	0.5/1.0	—	✓	—				8					0.65
UCC28220/1	3.3	4.5	Prog.	✓	—	—	—	0.01/0.01	Prog.	—	—			16	16				H, A	1.60
UCC3806	5.1	3	Prog.	✓	✓	✓	—	0.5/0.5	—	✓	—		16	16	16	16	20	16		4.10
UCC3808-1/-2/A-1/A-2	—	—	Prog.	✓	✓	—	—	1.0/0.5	—	✓	—			8	8			8		1.30
UCC38083/4/5/6	5	2	50	✓	—	—	—	1.0/0.5	Prog.	—	—			8	8			8		1.10
UCC3810	5	2	50	—	✓	✓	—	1/1	—	✓	—							16		1.85
Soft-Switching, ZVT and ZVS Controllers																				
UCC25600	—	—	Variable	✓	—	—	—	0.4/0.8	—	—	—				8					0.80
UC3875/6/7	5	2	Prog.	✓	✓	—	—	Four at 2/2	—	✓	—						20	28	20	4.85
UC3879	5	2.5	Prog.	✓	✓	—	—	Four at 0.1/0.1	—	✓	—						20	28	20	3.70
UCC2891/3	5	1	Prog.	✓	—	✓	—	2/2, 2/2	Prog.	✓	—			16	16					1.50
UCC2892/4	5	1	Prog.	✓	—	✓	—	2/2, 2/2	Prog.	✓	—			16	16					1.50
UCC2897A	5	1	Prog.	✓	—	✓	—	2/2, 2/2	Prog.	✓	—			20	16					1.50
UCC3580-1/-2/-3/-4	5	1	Prog.	✓	✓	✓	✓	0.5/1, 0.3/0.3	—	—	—				16					2.40
UCC3895	5	3	Prog.	✓	✓	✓	—	Four at 0.1/0.1	—	✓	—					20	20	20		4.35
Secondary-Side, Post Regulation																				
UCC3583	5	1.5	9.5	✓	✓	—	—	0.5/1.5	—	✓	—				14			20	14	1.75

¹Value varies by part number suffix. Please check datasheet.

Note: UC2xxx and UCC2xxx devices are extended temperature-range versions of the UC3xxx and UCC3xxx devices.

[†]Devices qualified for HiRel (H) or Automotive (A) applications are available with different pricing.

*Suggested resale price in U.S. dollars in quantities of 1,000.

New devices are listed in bold red.

→ MOSFET Drivers

Design Factors

Supply Voltage Range — With internal voltage regulators, MOSFET drivers can operate over a wide input voltage range, making them flexible for many applications.

Number of Outputs — Single and dual drivers are available to complement DC/DC switching and motor control applications.

Output Configuration — Inverting, non-inverting, AND and NAND configurations are available.

TrueDrive™ Output Stage — Used in TI high-current gate drivers and controllers, the TrueDrive output architecture is constructed of bipolar and CMOS transistors in parallel. TrueDrive technology delivers high current where it is needed most—at the MOSFET Miller plateau region thresholds—and provides switching efficiency gains.

Predictive Gate Drive™ Technology

— This patented TI technology is a digital control technique to control delay times in high-efficiency, low-output-voltage synchronous buck converters. See our application notes on Predictive Gate Drive for a complete description.

120-V Dual MOSFET High-Side, Low-Side Drivers

UCC27200, UCC27201

Get samples, datasheets and app reports at: www.ti.com/sc/device/UCC27200 or [UCC27201](http://www.ti.com/sc/device/UCC27201)

Key Features

- Drives two N-channel MOSFETs in high-side, low-side configuration
- Boot voltage absolute maximum: 120 V
- On-chip 0.65-V VF, 0.6-Ω RD bootstrap diode
- Up to 1-MHz operation
- 20-ns typical propagation delay
- 2.5-A sink, 2-A source output currents
- 10-ns rise and 8-ns fall time with 1000-pF load
- 2-ns typical delay matching
- Packaging: SOIC-8, PowerPAD™ SOIC-8 and space-saving DFN (all lead-free packages)

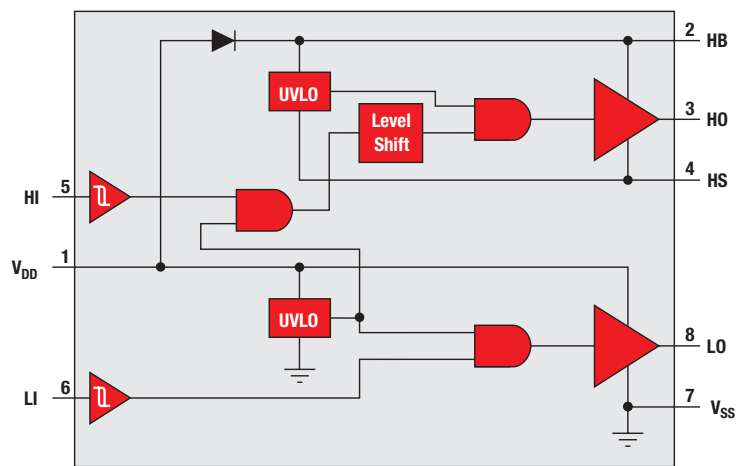

UCC27200/01 block diagram.

MOSFET Drivers Family of Products

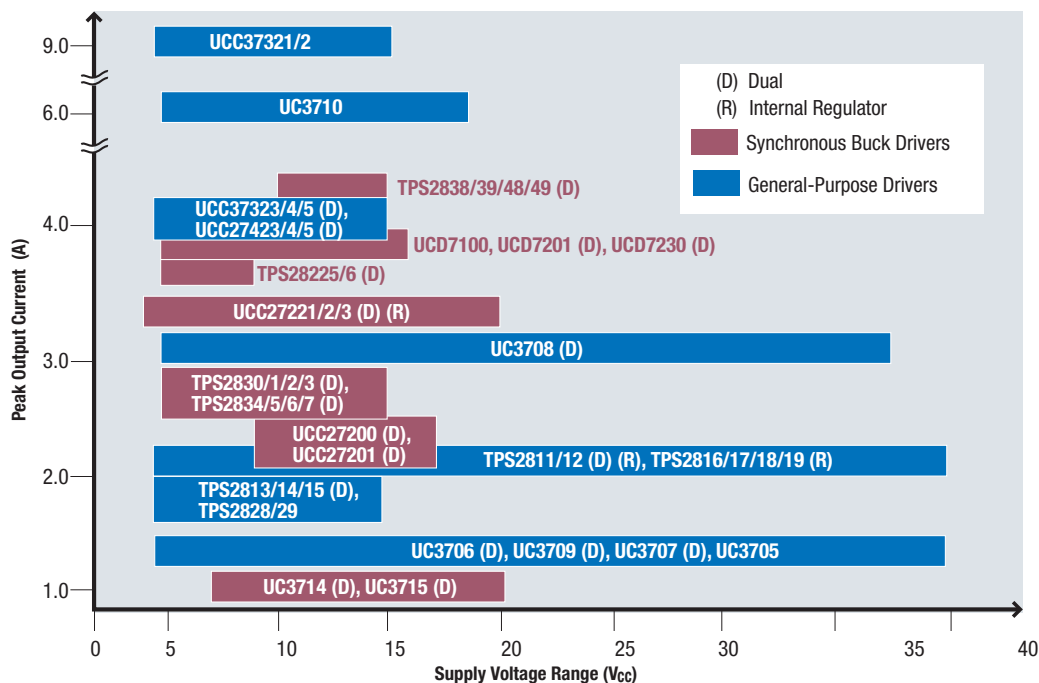



Selection Guide

Device	No. of Outputs	Output Configuration	Output Type ¹	Peak I _{OUT} Source/Sink (A)	Rise/Fall Time (ns)	V _{CC} Range (V)	Prop Delay (ns)	Input Threshold	Enable	Dead Time Control	Protection Features ²	Internal Regulator	HiRel (H) or Automotive (A) [†]	Price*
General-Purpose Low-Side Drivers														
TPS2811	2	Inverting	TrueDrive™	2.0/2.0	25/25	4 to 40	40	CMOS	—	—	—	✓		0.90
TPS2812	2	Non-inverting	TrueDrive	2.0/2.0	25/25	4 to 40	40	CMOS	—	—	—	✓		0.90
TPS2813	2	See Note 3	TrueDrive	2.0/2.0	25/25	4 to 14	40	CMOS	—	—	—	✓		0.90
TPS2814	2	Dual 2-input AND; one inverting	TrueDrive	2.0/2.0	25/25	4 to 14	40	CMOS	—	—	—	—		0.90
TPS2815	2	2-input NAND	TrueDrive	2.0/2.0	25/25	4 to 14	40	CMOS	✓	N/A	—	—		0.90
TPS2816	1	Inverting	TrueDrive	2.0/2.0	25/25	4 to 40	40	CMOS	—	N/A	—	✓		0.65
TPS2817	1	Non-inverting	TrueDrive	2.0/2.0	25/25	4 to 40	40	CMOS	—	N/A	—	✓		0.65
TPS2818	1	Inverting	TrueDrive	2.0/2.0	25/25	4 to 40	40	CMOS	—	N/A	—	✓	H	0.65
TPS2819	1	Non-inverting	TrueDrive	2.0/2.0	25/25	4 to 40	40	CMOS	—	N/A	—	✓	H	0.65
TPS2828	1	Inverting	TrueDrive	2.0/2.0	25/25	4 to 14	40	CMOS	—	N/A	—	—		0.60
TPS2829	1	Non-inverting	TrueDrive	2.0/2.0	25/25	4 to 14	40	CMOS	—	N/A	—	—	A	0.60
UC3714	2	Non-inverting	Bipolar	0.5/1.0	30/25	7 to 20	50	TTL/PWM	✓	Adj.	—	—		0.95
UC3715	2	See Note 3	Bipolar	1.0/2.0	30/25	7 to 20	50	TTL/PWM	✓	Adj.	—	—		0.90
UCC27323	2	Inverting	TrueDrive	4.0/4.0	25/25	4 to 15	35	TTL/CMOS	—	—	—	—		0.80
UCC27324	2	Non-inverting	TrueDrive	4.0/4.0	25/25	4 to 15	35	TTL/CMOS	—	—	—	—		0.80
UCC27325	2	See Note 3	TrueDrive	4.0/4.0	25/25	4 to 15	35	TTL/CMOS	—	—	—	—		0.80
UCC27423	2	Inverting	TrueDrive	4.0/4.0	25/25	4 to 15	35	TTL/CMOS	✓	—	—	—	A	0.85
UCC27424	2	Non-inverting	TrueDrive	4.0/4.0	25/25	4 to 15	35	TTL/CMOS	✓	—	—	—	H, A	0.85
UCC27425	2	See Note 3	TrueDrive	4.0/4.0	25/25	4 to 15	35	TTL/CMOS	✓	—	—	—	A	0.85
UCC37321	1	Inverting	TrueDrive	9/9	20/20	4 to 15	30	TTL/CMOS	✓	—	—	—		0.99
UCC37322	1	Non-inverting	TrueDrive	9/9	20/20	4 to 15	30	TTL/CMOS	✓	—	—	—		0.99
UCD7100PWP	1	Uncommitted/Non-inverting	TrueDrive	4/4	10/10	4.5 to 16	20	CMOS/TTL	—	Adaptive	—	—		0.99
UCD7201PWP	2	Uncommitted/Non-inverting	TrueDrive	4/4	10/10	4.5 to 16	20	CMOS/TTL	—	Adaptive	—	—		1.20
Synchronous Buck Drivers														
TPS28225	2	Non-inverting	CMOS	2.0/4.0	10/10	4.5 to 8.8	14	TTL/CMOS	✓	Adaptive	UVLO	—		0.60
TPS28226	2	Non-inverting	CMOS	2.0/4.0	10/10	4.5 to 8.8	14	TTL/CMOS	✓	Adaptive	UVLO	—		0.60
TPS2830	2	Non-inverting	TrueDrive	2.4/2.4	50/50	4.5 to 15	75	CMOS	✓	Adaptive	OVPC	—		1.05
TPS2831	2	Inverting	TrueDrive	2.4/2.4	50/50	4.5 to 15	75	CMOS	✓	Adaptive	OVPC	—		1.05
TPS2832	2	Non-inverting	TrueDrive	2.4/2.4	50/50	4.5 to 15	75	CMOS	—	Adaptive	—	—		1.00
TPS2833	2	Inverting	TrueDrive	2.4/2.4	50/50	4.5 to 15	75	CMOS	—	Adaptive	—	—		1.00
TPS2834	2	Non-inverting	TrueDrive	2.4/2.4	30/30	4.5 to 15	70	TTL	✓	Adaptive	OVPC	—		1.05
TPS2835	2	Inverting	TrueDrive	2.4/2.4	30/30	4.5 to 15	70	TTL	✓	Adaptive	OVPC	—		1.05
TPS2836	2	Non-inverting	TrueDrive	2.4/2.4	30/30	4.5 to 15	70	TTL	—	Adaptive	—	—		1.25
TPS2837	2	Inverting	TrueDrive	2.4/2.4	30/30	4.5 to 15	70	TTL	—	Adaptive	—	—		1.25
TPS2838	2	Non-inverting	TrueDrive	4/4	120	10 to 15	40	TTL	✓	Adaptive	—	✓		1.30
TPS2839	2	Inverting	TrueDrive	4/4	120	10 to 15	40	TTL	✓	Adaptive	—	✓		1.30
TPS2848	2	Non-inverting	TrueDrive	4/4	120	10 to 15	20	TTL	✓	Adaptive	—	✓		1.25
TPS2849	2	Inverting	TrueDrive	4/4	120	10 to 15	20	TTL	✓	Adaptive	—	✓		1.25
UCC27221	2	Inverting	TrueDrive	3.3/3.3	20/20	3.7 to 20	82/103	TTL	—	PGD ⁴	—	✓		1.35
UCC27222	2	Non-inverting	TrueDrive	3.3/3.3	20/20	3.7 to 20	82/103	TTL	—	PGD ⁴	—	✓		1.35
UCC27223	2	Non-inverting	TrueDrive	3.3/3.3	25/35	4.15 to 20	82/103	TTL	✓	PGD ⁴	—	✓		1.35
UCD7230	2	Non-inverting	CMOS	4/4	10/10	4.5 to 15.5	25	CMOS/TTL	—	Adaptive	Adjustable	—		0.80
High-Side Low-Side Drivers—Half Bridge, Full Bridge														
UCC27200	2	Non-inverting	TrueDrive	3/3	10/8	to 110 ⁵	20	CMOS	—	N/A	UVLO	—	A	1.30
UCC27201	2	Non-inverting	TrueDrive	3/3	10/8	to 110 ⁵	20	TTL	—	N/A	UVLO	—	A	1.30

¹ Output type: TrueDrive is the hybrid bipolar/CMOS output architecture for improved current drive capability at low voltages (at Miller threshold).

³ One inverting, one non-inverting.

New devices are listed in bold red.

² OCP = overcurrent protection, OVPC = overvoltage protection crowbar.

⁴ Predictive Gate Drive™.

⁵ Maximum boot voltage at HS pin.

[†] Devices qualified for HiRel (H) or Automotive (A) applications are available with different pricing.

*Suggested resale price in U.S. dollars in quantities of 1,000.



Design Factors

Plug-in power solutions are board-mounted, completely integrated, DC/DC converters requiring only one or two external components.

Input Voltage (V_{IN}) — Plug-in power solutions are designed to work from industry-standard DC bus voltages.

Output Current (I_{OUT}) — The I_{OUT} of the converter should match the maximum current need of your application.

Output Voltage (V_{OUT}) — Choose an adjustable or fixed V_{OUT} that meets your requirements.

Isolation — Converters with electrical input to output isolation are usually more complex and more expensive.

Features — *TurboTrans*[™], SmartSync, adjustable V_{OUT} , remote sense, over-temperature, overcurrent and output inhibit are some of the many features.

Airflow Requirements — The max current of converters often depends on airflow. Safe-operating-area (SOA) curves determine the airflow needs of converters at specific currents.

Protection — Fault protection can include short circuit, overtemperature, overcurrent and overvoltage protection.

Package — Vertical mounting uses the smallest footprint. Surface mount and horizontal through-hole are available in most product series.

16-A, 4.5-V to 14-V Input, POL Module with TurboTrans™ Technology

PTH08T220W

Get samples, datasheets and app reports at: www.ti.com/sc/device/PTH08T220W

The PTH08T220W is a high-performance, 16-A-rated, T2 point-of-load (POL) power module. Operating from an input voltage range of 4.5 V to 14 V, the PTH08T220W requires a single resistor to set the output voltage to any value over the range of 0.7 V to 5.5 V. The PTH08T220W incorporates *TurboTrans* technology, SmartSync and Auto-Track™ sequencing.

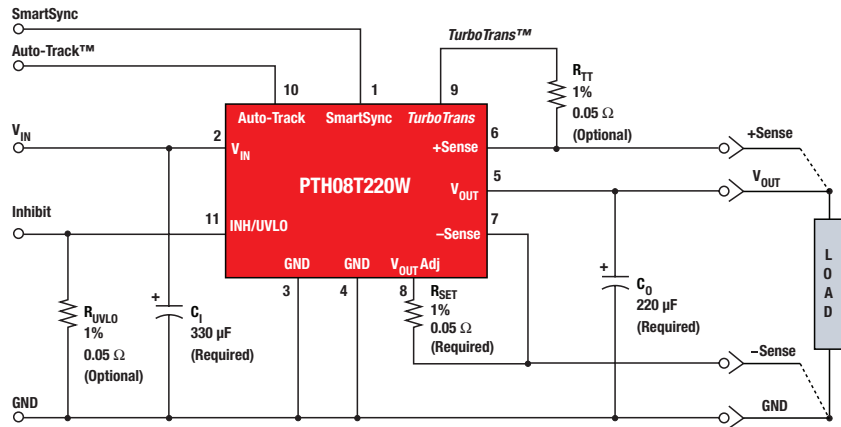

Plug-In Power Modules (POLA™ and Others) Family of Products

V_{IN}	1 A	2 A	3 A	5 A	8 A	15 A	20 A	30 A	60 A
48 V	PT4210 PT4310	PTMA PTB48540	PTMA PTB48540	PT4120 PTB48500 PTEA	PTB48560	PTB48501 PTB48502	PTB48520	PTQA PTQB	
24 V	DCP01/02 DCR01/02 DCV01 PTN78000	PT4240 PTN78060	PT4240 PTN78060	PT4140 PTN78020	PTB78560	PTB78520	PTB78520		
12 V	DCP02 DCR01/02 DCV01 PTN78000	PTN78060 PTH08000 PTH08080	PTH08T260 PTN78060	PTH08T230 PTN78020	PTH08T230 PTH12000 PTH12050 PTV12010 PTR08060	PTH08T240 PTH12060 PTH12010 PTR08100	PTH08T220 PTH12020 PTV12020	PTH08T210 PTH12030	PTH08T250 PTV08T250 PTV08040 PTH12040
5 V	DCH0105 DCP01/02 DCR01 DCV01 PTN04050	PTH04000 PTH04070	PTH04T260 PTH04000 PTH04070	PTH04T230 PTH05000	PTH04T230 PTH05050 PTV05010 PTR08060 PT6910 ♣	PTH04T240 PTH05060 PTH05010 PTR08100	PTH04T220 PTH05020 PTV05020	PTH05T210 PTH05030	PTH08T250 PTH04040
3.3 V		PTH04000 PTH04070	PTH04T260 PTH04000 PTH04070	PTH04T230 PTH03000 PT6910 ♣	PTH04T230 PTH03050 PTV03010 PT6910 ♣	PTH04T240 PTH03060 PTH03010	PTH04T220 PTH03020 PTV03020	PTH03030	PTH04040

♣ Special function; negative output

Isolated
 Non-Isolated



PTH Quad Data Rate (QDR)/Double Data Rate (DDR) Series Power Modules

PTHxx060Y

Get samples, datasheets and app reports at: www.ti.com/sc/device/PARTnumber

(Replace **PARTnumber** with **PTH03060Y**, **PTH05060Y** or **PTH12060Y**)

Key Features

- Non-isolated DC/DC modules for double data rate (DDR) and quad data rate (QDR) 1 and 2 memory bus terminations
- Generates termination voltage (V_{TT}) that will source or sink current to track an external reference voltage (V_{REF})
- V_{TT} tracks V_{DDQ} voltage with tolerance of ± 40 mV under transient conditions
- Supports V_{TT} range from 0.55 to 1.8 V
- 3.3-, 5- and 12-V input models
- Output currents up to 15 A
- POLA™ compatible

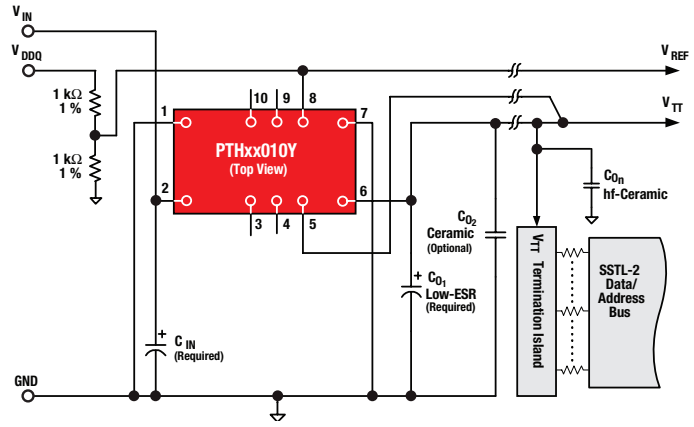

Standard application.

Selection Guide

Device ¹	Input Bus Voltage	Description	P _{OUT} or I _{OUT}	V _O Range (V)	V _O Adj.	Auto-Track™ Sequencing	POLA™	DDR-QDR	Price*
Non-Isolated Single Positive Output									
PTH03000W	3.3 V	3.3-V Input 6-A POL	6 A	0.8 to 2.5	✓				6.90
PTH03010W	3.3 V	3.3-V Input 15-A POL with Auto-Track Sequencing	15 A	0.8 to 2.5	✓	✓	✓		11.60
PTH03020W	3.3 V	3.3-V Input 22-A POL with Auto-Track Sequencing	22 A	0.8 to 2.5	✓	✓	✓		18.15
PTH03030W	3.3 V	3.3-V Input 30-A POL with Auto-Track Sequencing	30 A	0.8 to 2.5	✓	✓	✓		25.00
PTH03050W	3.3 V	3.3-V Input 6-A POL with Auto-Track Sequencing	6 A	0.8 to 2.5	✓	✓	✓		6.90
PTH03060W	3.3 V	3.3-V Input 10-A POL with Auto-Track Sequencing	10 A	0.7 to 2.5	✓	✓	✓		9.80
PTH04000W	3.3 V/5 V	3-V to 5.5-V Input 3-A POL with Auto-Track Sequencing	3 A	0.9 to 3.6	✓	✓	✓		4.50
PTH04070W	3.3 V/5 V	3-V to 5.5-V Input 3-A POL	3 A	0.9 to 3.6	✓				4.28
PTH04040W	3.3 V/5 V	3-V to 5.5-V Input 60-A POL with Auto-Track Sequencing	60 A	0.8 to 3.6	✓	✓	✓		35.00
PTH04T220/221W	3.3 V/5 V	2.2- to 5.5-V Input, 16-A T2 2nd Gen PTH POL with TurboTrans™	16 A	0.7 to 3.6	✓	✓	✓		12.60
PTH04T230/231W	3.3 V/5 V	2.2- to 5.5-V Input, 6-A T2 2nd Gen PTH POL with TurboTrans	6 A	0.7 to 3.6	✓	✓	✓		7.90
PTH04T240/241W	3.3 V/5 V	2.2- to 5.5-V Input, 10-A T2 2nd Gen PTH POL with TurboTrans	10 A	0.7 to 3.6	✓	✓	✓		10.80
PTH04T260/261W	3.3 V/5 V	2.2- to 5.5-V Input, 6-A T2 2nd Gen PTH POL with TurboTrans	3 A	0.7 to 3.6	✓	✓	✓		6.25
PTH05000W	5 V	5-V Input 6-A POL	6 A	0.8 to 3.6	✓				6.90
PTH05010W	5 V	5-V Input 15-A POL with Auto-Track Sequencing	15 A	0.8 to 3.6	✓	✓	✓		11.60
PTH05020W	5 V	5-V Input 22-A POL with Auto-Track Sequencing	22 A	0.8 to 3.6	✓	✓	✓		18.15
PTH05030W	5 V	5-V Input 30-A POL with Auto-Track Sequencing	30 A	0.8 to 3.6	✓	✓	✓		25.00
PTH05050W	5 V	5-V Input 6-A POL with Auto-Track Sequencing	6 A	0.8 to 3.6	✓	✓	✓		6.90
PTH05060W	5 V	5-V Input 10-A POL with Auto-Track Sequencing	10 A	0.8 to 3.6	✓	✓	✓		9.80
PTH05T210W	5 V	5-V Input, 30-A T2 2nd Gen PTH POL with TurboTrans	30 A	0.7 to 3.6	✓	✓	✓		18.00
PTH08000W	5 V/12 V	4.5-V to 18-V Input, 2.25-A POL with Auto-Track Sequencing	2.25 A	0.9 to 5.5	✓	✓	✓		4.50
PTH08080W	5 V/12 V	4.5-V to 18-V Input, 2.25-A POL	2.25 A	0.9 to 5.5	✓				4.28
PTH08T210W	12 V	5.5- to 14-V Input, 30-A T2 2nd Gen PTH POL with TurboTrans	30 A	0.7 to 3.6	✓	✓	✓		18.00
PTH08T220/221W	5 V/12 V	4.5- to 14-V Input, 16-A T2 2nd Gen PTH POL with TurboTrans	16 A	0.7 to 5.5	✓	✓	✓		12.60
PTH08T230/231W	5 V/12 V	4.5- to 14-V Input, 6-A T2 2nd Gen PTH POL with TurboTrans	6 A	0.7 to 5.5	✓	✓	✓		7.90
PTH08T240/241W	5 V/12 V	4.5- to 14-V Input, 10-A T2 2nd Gen PTH POL with TurboTrans	10 A	0.7 to 5.5	✓	✓	✓		10.80
PTH08T240F	5 V/12 V	4.5- to 14-V Input, 10-A T2 2nd Gen PTH POL for 3-GHz DSP Systems	10 A	0.7 to 2.0	✓	✓	✓		10.80
PTH08T250W	5 V/12 V	4.5- to 14-V Input, 50-A T2 2nd Gen PTH POL with TurboTrans	50 A	0.7 to 3.6	✓	✓	✓		36.00
PTH08T260/261W	5 V/12 V	4.5- to 14-V Input, 3-A T2 2nd Gen PTH POL with TurboTrans	3 A	0.7 to 5.5	✓	✓	✓		6.25
PTH12000L/W	12 V	12-V Input 6-A POL	6 A	0.8 to 1.8/1.2 to 5.5	✓				6.90
PTH12010L/W	12 V	12-V Input 12-A POL with Auto-Track Sequencing	12 A	0.8 to 1.8/1.2 to 5.5	✓	✓	✓		11.60
PTH12020L/W	12 V	12-V Input 18-A POL with Auto-Track Sequencing	18 A	0.8 to 1.8/1.2 to 5.5	✓	✓	✓		18.15

¹See power.ti.com for a complete product offering.

*Suggested resale price in U.S. dollars in quantities of 1,000.



Selection Guide (Continued)

Device ¹	Input Bus Voltage	Description	P _{OUT} or I _{OUT}	V _O Range (V)	V _O Adj.	Auto-Track™ Sequencing	POLA™	DDR-QDR	Price*
Non-Isolated Single Positive Output (Continued)									
PTH12030L/W	12 V	12-V Input 26-A POL with Auto-Track Sequencing	26 A	0.8 to 1.8/1.2 to 5.5	✓	✓	✓		25.00
PTH12040W	12 V	12-V Input 50-A POL with Auto-Track Sequencing	50 A	0.8 to 5.5	✓	✓	✓		35.00
PTH12050L/W	12 V	12-V Input 6-A POL with Auto-Track Sequencing	6 A	0.8 to 1.8/1.2 to 5.5	✓	✓	✓		6.90
PTH12060L/W	12 V	12-V Input 10-A POL with Auto-Track Sequencing	10 A	0.8 to 1.8/1.2 to 5.5	✓	✓	✓		9.80
PTH03010Y	3.3 V	3.3-V Input 15-A DDR Terminating Module	15 A	Follows V _{REF}	✓		✓	✓	11.60
PTH03050Y	3.3 V	3.3-V Input 6-A DDR Terminating Module	6 A	Follows V _{REF}	✓		✓	✓	6.90
PTH03060Y	3.3 V	3.3-V Input 10-A DDR Terminating Module	10 A	Follows V _{REF}	✓		✓	✓	9.80
PTH05010Y	5 V	5-V Input 15-A DDR Terminating Module	15 A	Follows V _{REF}	✓		✓	✓	11.60
PTH05050Y	5 V	5-V Input 6-A DDR Terminating Module	6 A	Follows V _{REF}	✓		✓	✓	6.90
PTH05060Y	5 V	5-V Input 10-A DDR Terminating Module	10 A	Follows V _{REF}	✓		✓	✓	9.80
PTH12010Y	12 V	12-V Input 12-A DDR Terminating Module	12 A	Follows V _{REF}	✓		✓	✓	11.60
PTH12050Y	12 V	12-V Input 6-A DDR Terminating Module	6 A	Follows V _{REF}	✓		✓	✓	6.90
PTH12060Y	12 V	12-V Input 8-A DDR Terminating Module	8 A	Follows V _{REF}	✓		✓	✓	9.80
PTN04050C	3.3 V/5 V	3-V/5-V Input, 12-W Output Step-Up (Boost) ISR	12 W	5 to 15	✓				8.00
PTN78000W/H	V _O + 2 to 36 V	Wide-Input, Wide-Output 1.5-A Positive Step-Down ISR	1.5 A	2.5 to 12/12 to 22	✓				8.00
PTN78060W/H	V _O + 2 to 36 V	Wide-Input, Wide-Output 3-A Positive Step-Down ISR	3 A	2.5 to 12/12 to 22	✓				11.00
PTN78020W/H	V _O + 2 to 36 V	Wide-Input, Wide-Output 6-A Positive Step-Down ISR	6 A	2.5 to 12/12 to 22	✓				15.00
PTR08060W	5 V/12 V	4.5- to 14-V Input, 6-A POL	6 A	0.6 to 5.5	✓				6.00
PTR08100W	5 V/12 V	4.5- to 14-V Input, 10-A POL	10 A	0.6 to 5.5	✓				8.00
PTV03010W	3.3 V	5-V Input 8-A Vertical SIP with Auto-Track Sequencing	8 A	0.8 to 2.5	✓	✓	✓		6.90
PTV03020W	3.3 V	5-V Input 18-A Vertical SIP with Auto-Track Sequencing	18 A	0.8 to 2.5	✓	✓	✓		11.60
PTV05010W	5 V	5-V Input 8-A Vertical SIP with Auto-Track Sequencing	8 A	0.8 to 3.6	✓	✓	✓		6.90
PTV05020W	5 V	5-V Input 18-A Vertical SIP with Auto-Track Sequencing	18 A	0.8 to 3.6	✓	✓	✓		11.60
PTV08T250W	12 V	8-V to 14-V Input, 50-A T2 2nd Gen PTH POL with TurboTrans™	50 A	0.8 to 3.6	✓	✓			36.00
PTV12010L/W	12 V	12-V Input 8-A Vertical SIP with Auto-Track Sequencing	8 A	0.8 to 1.8/1.2 to 5.5	✓	✓	✓		6.90
PTV12020L/W	12 V	12-V Input 18-A Vertical SIP with Auto-Track Sequencing	16 A	0.8 to 1.8/1.2 to 5.5	✓	✓	✓		11.60
Non-Isolated Single Negative Output									
PT6910	3.3 V/5 V	3.3-V/5-V Input 12-W Adjustable Plus to Minus Voltage Converter	12 W	-1.2 to -6.5	✓				26.25
PTN04050A	3.3 V/5 V	3-V to 5-V Input, 6-W Positive to Negative (Buck-Boost) ISR	6 W	-3.3 to -15	✓				8.00
PTN78000A	7 to 29 V	Wide-Input, Wide-Output 1.5-A Positive to Negative (Buck-Boost) ISR	1.5 A	-3 to -15	✓				8.00
PTN78060A	9 to 29 V	Wide-Input, Wide-Output 15-W Positive to Negative (Buck-Boost) ISR	15 W	-3 to -15	✓				11.00
PTN78020A	9 to 29 V	Wide-Input, Wide-Output 25-W Positive to Negative (Buck-Boost) ISR	25 W	-3 to -15	✓				15.00
Isolated Single Output									
DCH01_S	5	1-W Unregulated Isolated DC/DC Converter	1 W	5, 12, 15					4.25
DCP01_B	5, 24	1-W Unregulated Isolated DC/DC Converter with Synchronization	1 W	5, 12, 15					5.35
DCP02	5, 12, 24	2-W Unregulated Isolated DC/DC Converter with Synchronization	2 W	3.3, 5, 7, 9, 12, 15					6.95
DCR01	5, 12, 24	1-W Regulated Isolated DC/DC Converter with Synchronization	1 W	3.3, 5					5.95
PT4210	48 V	3- to 7-W 48-V Input Isolated DC/DC Converter	3 to 7 W	3.3 to 12					18.75
PTB48520W	48 V	25-A 48-V Input Isolated POL Converter with Auto-Track I/O	75 W	1.8 to 3.6	✓	✓			62.00
PTB48540A/B/C	48 V	10-W 48-V Input Isolated PoE Module	10 W	3.3, 5, 12	✓				26.00
PTB48560A/B/C	48 V	30-W 48-V Input Isolated POL Converter with Auto-Track I/O	30 W	3.3, 5, 12	✓	✓			25.00
PTB78520W	18 V to 60 V	20-A 18-V to 60-V Input Isolated POL Converter with Track I/O	65 W	1.8 to 3.6	✓	✓			62.00
PTB78560A/B/C	18 V to 60 V	30-W 18-V to 60-V Input Isolated POL Converter with Track I/O	30 W	3.3, 5, 12	✓	✓			25.00
PTEA4	48 V	50-W 48-V Input Isolated DC/DC Converter—Industry Std Footprint	50 W	2.5, 3.3, 12	✓				26.50
PTMA4	48 V	10-W 48-V Input Isolated DC/DC Converter—Industry Std Footprint	10 W	3.3, 5, 12	✓				20.00
PTQA4	48 V	100-W 48-V Input Isolated DC/DC Converter—Industry Std Footprint	100 W	2.5, 3.3, 5	✓				44.00
PTQB4	48 V	200-W 36- to 75-V Input Isolated Bus Converter w Auto-Track	200 W	8		✓			45.00
Isolated Multiple Output									
DCH01_D	5	1-W Unregulated Isolated DC/DC Converter	1 W	±5, ±12, ±15					4.25
DCP01_DB	5, 15, 24	1-W Unregulated Dual Isolated Converter with Synchronization	1 W	±5, ±12, ±15					5.90
DCP02_D	5, 12, 24	2-W Unregulated Dual Isolated Converter with Synchronization	2 W	±5, ±12, ±15					6.95
PTB48500A	48 V	30-W 48-V Input Isolated Dual DC/DC Converter	30 W	3.3/1.2	✓				43.00
PTB48501A/B	48 V	35-W 48-V Input Isolated Dual DC/DC Converter	35 W	3.3/1.2 or 1.5	✓				45.00
PTB48502A/B	48 V	40-W 48-V Input Isolated Dual DC/DC Converter	40 W	3.3/1.2 or 1.5	✓				49.00

¹See power.ti.com for a complete product offering.

*Suggested resale price in U.S. dollars in quantities of 1,000.

New devices are listed in bold red.

Linear and Low Dropout (LDO) Regulators



TI offers an extremely broad LDO portfolio covering applications from microampere keep-alive circuits to 7.5-A telecom loads. For a more comprehensive selection, please review pages 28–29 or visit power.ti.com for our complete portfolio.

Design Factors

Input Voltage — The minimum V_{IN} must be larger than $V_{OUT} + V_{DO}$, independent from the minimum value given in the selection table.

Efficiency — By neglecting the quiescent current (I_Q) of the LDO, efficiency can be calculated as V_{OUT}/V_{IN} .

Power Dissipation — $P_D = (V_{IN} - V_{OUT}) \times I_{OUT}$; P_D is limited by package, T_A and T_{JMAX} . Refer to application note SLVA118, “Digital Designer’s Guide to Linear Voltage Regulators and Thermal Management,” for support. For higher

power dissipation or requirements for higher efficiency, TI recommends step-down (buck) DC/DC converters/controllers (refer to pages 31–39 for products).

Capacitor Requirements — The output capacitor and especially its effective series resistance (ESR) are critical for stability. Therefore, some LDOs require tantalum output capacitors, which have high ESR. If an LDO is stable with no output capacitor or with low-ESR ceramic output capacitors, it is usually stable with all types of capacitors.

RF, Audio and Other Noise-Sensitive Applications — Select an LDO with high power supply ripple rejection (PSRR) for noise immunity from the input supply, and low output noise ($< 50 \mu\text{Vrms}$). Some LDOs have a bypass (BP) pin for adding capacitance to lower the output noise.

PG/SVS — Devices such as microprocessors, DSPs and FPGAs require a minimum voltage for proper operation. The supply voltage supervisor (SVS) function monitors the system voltages and outputs a signal when the voltages drop below a certain value, so the system can reset and prevent malfunction. An SVS asserts the reset signal after a specified delay, while a power-good (PG) function does not have a delay.

Reverse Leakage Protection — In special applications where the voltage on the output of the LDO is higher than at the input, the reverse leakage protection feature prevents current from flowing from the LDO output to the input, which can be damaging to the input supply, especially if it is a battery.

Application-Specific Multi-Output Solutions — See pages 40–41.

High-Current LDO Family with Soft Start or Tracking

TPS74701

Get samples, datasheets, evaluation modules and app reports at: www.ti.com/sc/device/TPS74701

The TPS74xxx family of LDOs provides an easy-to-use, robust power management solution for a wide variety of applications. User-programmable soft start minimizes stress on the input power source by reducing capacitive inrush current on start up. The soft start is monotonic and well suited for powering many different types of processors and ASICs. The enable input and power good output allow easy sequencing with external regulators. This complete flexibility permits the user to configure a solution that meets the sequencing requirements of FPGAs, DSPs and other applications with special start-up requirements.

Key Features

- Output voltage: Adjustable from 0.8 V to 3.3 V
- Ultralow dropout from 50 mV to 120 mV
- Soft start or tracking
- 1 or 2% accuracy over load/temp/line
- 2.2- μF or no output capacitor needed

- Packaging: Low-profile 3 x 3/5 x 5 QFN or 7-pin DDPACK
- V_{BIAS} voltage allows $>80\%$ efficiency

Applications

- DSP/FPGA power supplies
- Post regulation
- Medical equipment

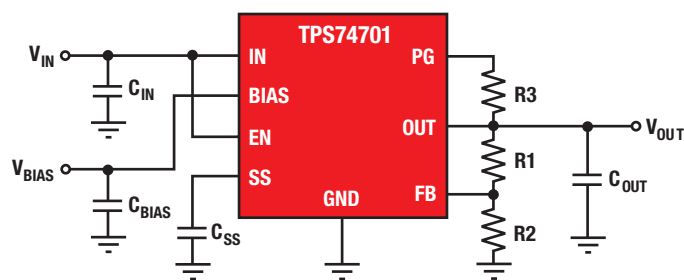

TPS74701 typical application.

Selection Guide

Device	Output Current	V_{DO} (mV)	Accuracy (%)	Feature	C_{OUT} (μF)
TPS720xx	350 mA	100	2	Soft Start	2.2
TPS747xx	500 mA	50	2	Soft Start	2.2
TPS748xx	1.5 A	60	2	Soft Start	2.2
TPS742xx	1.5 A	55	1	Soft Start	—
TPS743xx	1.5 A	55	1	Tracking	—
TPS749xx	3.0 A	120	2	Soft Start	2.2
TPS744xx	3.0 A	115	1	Soft Start	—

Linear and Low Dropout (LDO) Regulators

Low Dropout (LDO) Regulators Selection Guide

Device ¹	Min V _{IN}	Max V _{IN}	I _O (mA)	V _{DO} at I _O (mV)	I _q (µA)	Output Options		Accuracy (%)	Packages(s)								Features ²	C ₀ ³	Comments	HiRel (H) or Automotive (A) [†]	Price*
						Fixed Voltage (V)	Adj. (V)		WCSOP	SC70	SOT23	MSOP	DFN	S08	SOT23	PWP					
Positive Voltage, Single Output Devices																					
TPS797xx	1.8	5.5	50	105	1.2	1.8, 2.85, 3.0, 3.3	—	4	✓							✓	PG	1µF, C	MSP430; lowest Iq	H, A	0.34
TPS715xx	2.5	24	50	415	3.2	1.8, 1.9, 2.3, 2.5, 3.0, 3.3, 4.5, 5.0	1.2 to 15	4	✓							✓	—	1µF, C	Wide Vin low Iq	H, A	0.34
TPS714xx	2.5	10	80	620	3.2	3.3	1.2 to 8.8		✓									1µF, C	Wide Vin, low Iq, low cost		0.28
TPS715Axx	2.5	24	80	670	3.2	3.3	1.2 to 15	4				✓					—	1µF, C	Wide Vin low Iq		0.44
TPS789xx	2.7	13.5	100	115	18	1.5, 1.8, 2.5, 2.8, 3.0	—	3		✓							/EN	4.7 µF, T	Low Iq and high VIN		0.30
TPS792xx	2.7	5.5	100	38	185	2.5, 2.8, 3	1.2 to 5.5	2		✓						✓	EN, BP	1 µF, C	RF low noise; high PSRR		0.40
TPS769xx	2.7	10	100	70	18	1.2, 1.5, 1.8, 2.5, 2.7, 2.8, 3.0, 3.3, 5.0	1.2 to 5.5	3		✓						✓	/EN	4.7 µF, T	Low cost	H, A	0.29
LP2950	2.3	30	100	380	75	3.0, 3.3, 5.0	—	1									—	1 µF, C	Available in T092 and T0252		0.27
LP2981	2.2	16	100	200	600	1.8, 2.5, 2.8, 3.0, 3.3, 5	1.3 to 9	1			✓						EN	3.3 µF, C	Fast transient response		0.36
TPS717xx	2.5	6.5	150	170	50	0.9, 1.0, 1.1, 1.2, 1.3, 1.5, 1.8, 1.85, 1.9, 2.1, 2.5, 2.6, 2.7, 2.8, 2.85, 2.9, 3.0, 3.3, 4.5, EEPROM ⁴	0.9 to 6.2	1.5	✓			✓					EN, BP	1 µF, C	Ultra-high PSRR		0.36
TPS731xx	1.7	5.5	150	30	400	1.5, 1.8, 2.5, 3.0, 3.3, 5.0, EEPROM ⁴	1.2 to 5.5	1			✓						EN, BP	No Cap	Reverse leakage protection	H	0.45
TPS780xx	2.2	5.5	150	130	0.5	3.3/2.2, 2.3/3.0, 2.7/2.0, 3.0/2.5 EEPROM ⁴	1.22 to 5.25	3			✓		✓				EN, VSET	1.0 µF, C	Dual-level output, low Iq		0.50
TPS781xx	2.2	5.5	150	130	1.0	3.3/2.2, EEPROM ⁴	1.22 to 5.25	3			✓		✓				EN, VSET	1.0 µF, C	Dual-level output, low Iq		0.42
TPS782xx	2.2	5.5	150	130	1	2.3, 2.5, 2.7, 2.8, 3.0, 3.3, EEPROM ⁴	—	3			✓		✓				EN	1µF, C	Low Iq, low price		0.35
TLV700xx	2	5.5	150	125	29	1.2, 1.5, 1.8, 2.8, 3.0, 3.3	—	2	✓	✓	✓	✓					EN	1µF, C	Low price, high performance		0.18
LP2985	2.2	16	150	280	850	1.8, 2.5, 2.8, 3.3, 5.0, 10	—	1	✓	✓	✓	✓					EN	3.3 µF, C	Fast transient response		0.36
TPS730xx	2.7	5.5	200	120	180	1.8, 2.5, 2.8, 2.85, 3.0, 3.3, 4.7	1.22 to 5.5	2			✓						EN, BP	2.2 µF, C	Low price		0.23
TPS727xx	2	5.5	200	130	7.9	1.5, 1.8, 2.5	—	2	✓				✓				EN	1µF, C	Low Iq, high performance		0.48
TPS728xx	2.7	6.5	200	230	45	3.15/1.85, 1.5/1.2 EEPROM ⁴	—	3	✓				✓				EN, VSET	1.0 µF, C	Dual-level output (H/L)		0.39
TPS799xx	2.7	6.5	200	100	40	1.2, 1.3, 1.5, 1.8, 1.85, 1.9, 1.95, 2.0, 2.1, 2.5, 2.6, 2.7, 2.75, 2.8, 2.85, 3.0, 3.15, 3.2, 3.3, 4.2, 4.5 EEPROM ⁴	1.2 to 5.5	2	✓		✓		✓				EN, BP	2.2 µF, C	Low power vs. TPS793xx	A	0.30
TPS734xx	2.7	6.5	250	113	44	1.8, 3.0, 3.3, EEPROM ⁴	1.2 to 6.5	2			✓		✓				EN	2.0 µF, C	High PSRR, low noise		0.35
TPS794xx	2.7	5.5	250	145	172	1.8, 2.5, 2.8, 3.0, 3.3	1.2 to 5.5	3				✓		✓			EN, BP	2.2 µF, C	RF low noise, high PSRR		0.65
TPS732xx	1.7	5.5	250	40	400	1.3, 1.5, 1.6, 1.8, 1.9, 2.5, 3.0, 3.3, 5.0, EEPROM ⁴	1.2 to 5.5	1			✓		✓				EN, BP	No Cap	Reverse leakage protection	H, A	0.65
TPS773xx	2.7	10	250	125	90	1.5, 1.6, 1.8, 2.7, 2.8, 3.3, 5.0	1.5 to 5.5	2				✓					/EN, SVS	10 µF, T	Low noise		0.70
TPS720xx	1.1	4.5	350	100	29	1.0, 1.05, 1.2, 1.3, 1.5, 1.7, 1.8, EEPROM ⁴	—	2	✓								EN	2.2 µF, C	High PSRR		0.48
TPS736xx	1.7	5.5	400	75	300	1.25, 1.5, 1.6, 1.8, 1.9, 2.5, 3.0, 3.2, 3.3, 4.3 EEPROM ⁴	1.2 to 5.5	1			✓		✓				EN, BP	No Cap	Reverse leakage protection	H	0.85
TPS747xx	0.8	5.5	500	50	1 mA	EEPROM ⁴	0.8 to 3.6	2					✓				EN, SS, PG	2.2 µF, C	Low VOUT, low dropout		1.00
TPS735xx	2.7	6.5	500	113	46	2.5, 3.3 EEPROM ⁴	1.2 to 6.5	2					✓				EN	2.0 µF, C	High PSRR, low noise		0.75
TPS795xx	2.7	5.5	500	105	265	1.6, 1.8, 2.5, 3.0, 3.3	1.2 to 5.5	2					✓				EN, BP	1 µF, C	RF low noise, high PSRR		1.05
TPS775xx	2.7	10	500	169	87	1.5, 1.6, 1.8, 2.5, 3.3	1.5 to 5.5	2					✓				/EN, SVS	10 µF, T	Fast transient response	H, A	0.95
TPS776xx	2.7	10	500	169	87	1.5, 1.8, 2.5, 2.8, 3.3	1.2 to 5.5	2					✓				/EN, PG	10 µF, T	Fast transient response	H, A	0.70
TPS777xx	2.7	10	750	260	85	1.5, 1.8, 2.5, 3.3	1.5 to 5.5	2					✓				/EN, SVS	10 µF, T	Fast transient response		1.05
TLV1117-xx	2.7	15	800	1200	5	1.5, 1.8, 2.5, 3.3, 5.0	1.24 to 13.5	1					✓					10 µF, T	Low price		0.16
TPS737xx	2.2	5.5	1000	200	300	1.8, 1.9, 2.5, 3.0, 3.3, 4.3, EEPROM ⁴	1.2 to 5.5	3					✓				EN	1 µF, C	Low price	A	0.60
TPS725xx	1.8	6	1000	170	75	1.5, 1.6, 1.8, 2.5	1.2 to 5.5	2					✓				EN, SVS	No Cap	Low noise; SVS delay 50 ms		1.10
TPS796xx	2.7	5.5	1000	200	310	1.8, 2.5, 2.8, 3.0, 3.3	1.2 to 5.5	2					✓				EN, BP	1 µF, C	RF low noise, high PSRR		1.10
TPS767xx	2.7	10	1000	230	85	1.5, 1.8, 2.5, 2.7, 2.8, 3.0, 3.3, 5.0	1.5 to 5.5	2					✓				/EN, SVS	10 µF, T	Fast transient response	H, A	1.10
TPS768xx	2.7	10	1000	230	80	1.5, 1.8, 2.5, 2.7, 2.8, 3.0, 3.3, 5.0	1.2 to 5.5	2					✓				/EN, PG	10 µF, T	Fast transient response	H, A	0.90
TPS742xx	0.8	5.5	1500	55	2 mA	EEPROM ⁴	0.8 to 3.3	1					✓				EN, SS, PG	No Cap	Low VOUT, high accuracy		1.70
TPS743xx	0.8	5.5	1500	55	2 mA	EEPROM ⁴	0.8 to 3.3	1					✓				EN, TR, PG	No Cap	Low VOUT, high accuracy		2.00
TPS748xx	0.8	5.5	1500	60	1 mA	—	0.8 to 3.3	2					✓				EN, SS, PG	2.2 µF, C	Low VOUT		1.25
TPS786xx	2.7	5.5	1500	390	310	1.8, 2.5, 2.8, 3.0, 3.3	1.2 to 5.5	2					✓				EN, BP	1 µF, C	RF low noise, high PSRR		1.35
TPS7A45	2.2	20	1500	300	1 mA	1.5, 1.8, 2.5, 3.3	1.2 to 20	1					✓				EN	10µF, C	Wide Vin high performance		1.45
TL1963A	2.2	20	1500	340	1 mA	1.5, 1.8, 2.5, 3.3	1.21 to 21	1					✓				EN	10 µF, C	Wide Vin high performance		1.35

¹xx represents the voltage option. For example, 33 represents the 3.3-V option. The adjustable output voltage option is represented by 01.

²BP = bypass pin for noise reduction capacitor, EN = active high enable, /EN = active low enable, PG = Power Good, SS = soft-start pin, SVS = supply voltage supervisor, TR = tracking, VSET = dual-level output voltage select pin (H/L).

³C = ceramic, T = tantalum, No Cap = capacitor-free LDO.

⁴EEPROM programmable at the factory, allowing production of custom fixed voltages. Minimum quantities apply. Please contact TI.

*Suggested resale price in U.S. dollars in quantities of 1,000.

[†]Devices qualified for HiRel (H) or Automotive (A) applications are

available with different pricing. Certain voltage options are not available.

New devices are listed in bold red.

Linear and Low Dropout (LDO) Regulators



Low Dropout (LDO) Regulators Selection Guide (Continued)

Device ¹	Min V _{IN}	Max V _{IN}	I _O (mA)	V _{DO} at I _O (mV)	I _q (μA)	Output Options		Accuracy (%)	Packages(s)								Features ²	C ₀ ³	Comments	HiRel (H) or Automotive (A) [†]	Price*		
						Fixed Voltage (V)	Adj. (V)		WCS ⁴	SC70	SOT23	MSOP	QFN	S08	SOT23	PWP						TO220	PW
Positive Voltage, Single Output Devices (Continued)																							
TPS752xx	2.7	5	2000	210	75	1.5, 1.8, 2.5, 3.3	1.5 to 5.0	2								✓		✓	/EN, SVS	47 μF, T	Fast transient response	H, A	1.80
TPS744xx	0.8	5.5	3000	115	2 mA	EEPROM ⁴	0.8 to 3.3	1										✓	EN, SS, PG	No Cap	Low V _{OUT} , high accuracy		2.95
TPS749xx	0.8	5.5	3000	120	1 mA	—	0.8 to 3.3	2										✓	EN, SS, PG	2.2 μF, C	Low V _{OUT}		2.00
TPS51100	4.75	5.25	3000	1250	3	1/2 VDDQSNS	—	1.6											EN	20 μF, C	DDR/DDR2 VH power		0.80
TPS758xx	2.8	5.5	3000	150	110	1.5, 1.8, 2.5, 3.3	1.2 to 5.0	3											EN	47 μF, T	Fast transient response		2.70
UC385-x	1.7	7.5	5000	350	8 mA	1.5, 2.1, 2.5	1.2 to 6.0	1											—	100 μF, T	Fast LDO with reverse leak.		3.15
TPS756xx	2.8	5.5	5000	250	110	1.5, 1.8, 2.5, 3.3	1.2 to 5.0	3											EN	47 μF, T	Fast transient response		3.00
TPS759xx	2.8	5.5	7500	400	110	1.5, 1.8, 2.5, 3.3	1.2 to 5.0	3											/EN, PG	47 μF, T	Fast transient response		3.20
Negative Voltage, Single Output Devices																							
TPS723xx	-10	-2.7	200	280	130	-2.5	-1.2 to -9	2				✓							EN, BP	2.2 μF, C	Low noise, high PSRR		1.05
UCC384-x	-15	-3.5	500	150	200	-12.0, -5.0	-1.25 to -15	3											/EN	4.7 μF, T	Duty cycled short		1.86

¹xx represents the voltage option. For example, 33 represents the 3.3-V option. The adjustable output voltage option is represented by 01.

²BP = bypass pin for noise reduction capacitor, EN = active high enable, /EN = active low enable, PG = Power Good, SS = soft-start pin, SVS = supply voltage supervisor, TR = tracking, VSET = dual-level output voltage select pin (H/L).

³C = ceramic, T = tantalum, No Cap = capacitor-free LDO.

⁴EEPROM programmable at the factory, allowing production of custom fixed voltages. Minimum quantities apply. Please contact TI.

[†]Devices qualified for HiRel (H) or Automotive (A) applications are available with different pricing. Certain voltage options are not available.

*Suggested resale price in U.S. dollars in quantities of 1,000.

Dual Channel LDO Selection Guide

Device	I _{O1} (mA)	I _{O2} (mA)	V _{DO1} at I _{O1} (mV)	V _{DO2} at I _{O2} (mV)	I _q (μA)	Output Options		Accuracy (%)	Package(s)	V _O		Features					C ₀ ¹	Comments	Price*			
						Fixed Voltage (V)	Adj.			(min)	(max)	Enable	PG	SVS	Seq	Low Noise				V _{IN} (min)	V _{IN} (max)	
TPS51103	100	100	400	400	35	3.3/5.0	—	2	QFN	—	—	EN						4.5	28	100 μF, C	250-kHz clock output for charge pump, always-on 3.3-V, 5-mA LDO output for RTC	1.00

¹C = ceramic.

*Suggested resale price in U.S. dollars in quantities of 1,000.

Dual Output LDOs Selection Guide

Device	I _{O1} (mA)	I _{O2} (mA)	V _{DO1} at I _{O1} (mV)	V _{DO2} at I _{O2} (mV)	I _q (μA)	Output Options		Accuracy (%)	Package(s)	V _O		Features					C ₀ ¹	Comments	HiRel (H) or Automotive (A) [†]	Price*			
						Fixed Voltage (V)	Adj.			(min)	(max)	Enable	PG	SVS	Seq	Low Noise					V _{IN} (min)	V _{IN} (max)	
TPS719xx	200	200	230	230	100	1.3/2.8, 1.8/1.2, 1.8/1.3, 2.1/2.2, 2.6/1.5, 2.8/2.8, 2.85/2.85, 3.3/2.8, 3.3/3.3, 3.6/3.15 See Note 2	—	3	QFN/WCSP	0.9	3.6	EN					✓	2.5	6.5	1.0 μF	TPS718xx w/ Active Output Pulldown		0.55
TPS718xx	200	200	230	230	100	1.2/3.3, 1.8/2.7, 1.8/3.3, 2.5/1.2, 2.8/2.8, 2.8/3.0 See Note 2	—	3	QFN/WCSP	0.9	3.6	EN					✓	2.5	6.5	1.0 μF	High PSRR, Low V _{OUT}		0.55
TPS712xx	250	250	145	145	400	1.8/2.85, 1.8/Adj., 2.8/2.8, 2.8/Adj., 2.85/2.85	✓	2	QFN	1.2	5.5	EN					✓	2.7	5.5	2.2 μF, C		H	0.80
TPS713xx	250	250	145	145	400	3.3/Adj., 1.8/Adj.	✓	2	QFN	1.2	5.5	EN		✓			✓	2.7	5.5	2.2 μF, C	Integrated SVS		0.90
TPS707xx	250	150	83	125	187	See Web	✓	2	PWP	1.2	5	EN	✓	✓	✓	✓	✓	2.7	5.5	10 μF, T	See TPS708xx ³	H	1.20
TPS701xx	500	250	170	220	187	See Web	✓	2	PWP	1.2	5	EN	✓	✓	✓	✓	✓	2.7	5.5	10 μF, T	See TPS702xx ³	A	1.50
TPS767D3xx	1000	1000	350	350	85	3.3/2.5, 3.3/1.8	✓	2	PWP	1.5	5.5	EN		✓				2.7	10	10 μF, T	Dual Output Fast LDO with Integrated SVS	H, A	2.00
TPS703xx	1000	2000	160	190	185	See Web	✓	2	PWP	1.2	5.5	EN	✓	✓	✓	✓	✓	2.7	5.5	22 μF, T	See TPS704xx ³	H	2.35
TPPM0110/1	1500	300	1000	2500	1000	3.3/1.8, 3.3/1.5	—	2	—	1.8	3.3	—						4.7	5.3	100 μF, T	See TPPM0111 for 3.3-V/1.5-V Output		1.60

¹C = ceramic, T = tantalum.

²EEPROM programmable at the factory, allowing production of custom fixed voltages. Minimum quantities apply. Please contact TI.

³For independent enables instead of integrated sequencing.

[†]Devices qualified for HiRel (H) or Automotive (A) applications are available with different pricing. Certain voltage options are not available.

*Suggested resale price in U.S. dollars in quantities of 1,000.

→ Linear and Low Dropout (LDO) Regulators

Standard Linear Voltage Regulators Selection Guide

Device	V _{IN}		I _{OUT} (max) (mA)	V _{OUT} (nom) (V)	HiRel (H) or Automotive (A) [†]	Price*
	MIN (V)	MAX (V)				
LM237, LM337	-4.2	-40	1500	Adj. (-1.2 to -37)		0.29
LM317, LM317M	4.2	40	1500, 500	Adj. (1.2 to 37)		0.27
MC79Lxx/A	-7	-20	100	-5, -12, -15		0.13
TL317/L/M	4.2	40	1500/100/500	Adj. (1.2 to 35)		0.14
TL780-xx	7	25	1500	5, 12, 15		0.32
TL783	21.5	125	700	Adj. (1.25 to 125)		1.15
UA723	5	40	150	Adj. (2 to 37)		0.29
UA78Lxx/A	4.75	20	100	2.6, 5, 6.2, 8, 9, 10, 12, 15		0.11
UA78Mxx	7	25	500	3.3, 5, 6, 8, 9, 12	A	0.25
UA78xx	7	25	1500	5, 8, 10, 12, 15, 24		0.23
UA79xx	-7	-25	1500	-5, -8, -12, -15	H	0.25
UA79Mxx	-10.5	-25	500	-5, -8		0.25

[†]Devices qualified for HiRel (H) or Automotive (A) applications are available with different pricing. Certain voltage options are not available.

*Suggested resale price in U.S. dollars in quantities of 1,000.

DC/DC Controllers (External Switch)



Design Factors

Input Voltage — More than one voltage may be available on the circuit board. One voltage can operate the controller IC, while another voltage can be used in the power conversion section. Choose the most suitable voltage that can handle the current needed by the system.

Output Voltage — The output voltage can be adjusted down to the controller reference voltage by using a voltage divider.

Output Current — Output current is ultimately set by external power MOSFETs. The drive current and output current values given in the table are guidelines only! They assume no paralleling of multiple MOSFETs, and characteristics of

common MOSFETs generally available in the market. Paralleling multiple power MOSFETs can control higher currents, as long as the MOSFET drivers can adequately drive the external FETs.

Efficiency — Higher efficiency will help with thermal issues, since wasted power is converted into heat. Higher currents quickly generate more heat, so airflow and board space (and their cost) must be considered.

Switching Frequency — Higher switching frequency provides lower ripple but also lowers efficiency as the MOSFET transitions its active region more often. EMI issues may also be more complicated at higher frequency.

Accuracy — Today's advanced

processors need better accuracy to support lower core voltages. There is a cost tradeoff when a more accurate controller is needed.

Pre-Biased Operation — Voltages present on the outputs of the controller when it turns on may prevent start-up and/or cause other complications. Controllers designed for pre-biased operation can tolerate a pre-biased condition and safely start up.

Protection Features — Applications that use many expensive processors and peripheral ICs on a single board can benefit from the long-term reliability ensured by implementing the controller's protection features.

Selection Guide

All parts have soft start, short-circuit protection, and undervoltage lockout functions.

Device	Mode of Control ¹	V _{IN} (min/max) (V)	V _O (min/max) (V)	Driver Current (A)	Output Current (A) ²	Frequency (kHz)	V _{REF} Tol (%)	Internal Bootstrap	Package(s)	Pwr Good	Source & Sink ³	Pre-biased Operation	Ext Synchron Pin	Predictive Gate Drive™	DDR ⁴	Remote Sense	HiRel (H) or Automotive (A) [†]	Price*
General-Purpose DC/DC Voltage Mode Buck Controllers (All devices in this family except the TPS40200 are synchronous.)																		
TPS40000/2	V	2.25/5.5	0.7/4	1	15	300/600	1	Yes	10 MSOP	No	No	Yes	No	Yes	No	No		0.99
TPS40007/9	V	2.25/5.5	0.7/4	1	15	300/600	1	Yes	10 MSOP	No	Yes ¹¹	Yes	No	Yes	No	No		1.20
TPS40020/21	V	2.25/5.5	0.7/4	2	25	Adj. to 1000	1	Yes ¹⁰	16 HTSSOP	Yes	21 ¹¹	20	Yes	Yes	No	No		1.45
TPS40040	V	2.25/5.5	0.6/4.95	1	15	300	1	Yes	8 SON	No	Yes ¹¹	Yes	No	No	No	No		0.90
TPS40041	V	2.25/5.5	0.6/4.88	1	15	600	1	Yes	8 SON	No	Yes ¹¹	Yes	No	No	No	No		0.90
TPS40042	V	3/5.5	0.7/4.95	1.2	15	600	Ext	Yes	10 SON	No	Yes ¹¹	Yes	No	No	Yes	No		0.90
TPS40054/55/57	VFF	8/40	0.7/35	1	20	Adj. to 1000	1	Yes	16 PwrPAD	No	55, 57 ¹¹	57	Yes	No	No	No	H	1.65
TPS40056	V	10/40	0.7/35	1	20	Adj. to 1000	Ext	Yes	16 PwrPAD	No	Yes	No	Yes	No	Yes	No		1.65
TPS40060/61 ⁵	VFF	10/55	0.7/45	1	10	Adj. to 1000	1	No ⁵	16 PwrPAD	No	61	No	Yes	No	No	No		1.85
TPS40075	VFF	4.5/28	0.7/23	1	20	Adj. to 1000	1	Yes	20 QFN	Yes	Yes ¹¹	Yes	Yes	Yes	No	Yes		1.80
TPS40077	VFF	4.5/28	0.7/23	1	20	Adj. to 1000	1	Yes	16 PwrPAD	Yes	Yes ¹¹	Yes	No	Yes	No	No		1.60
TPS40100 ⁶	C	4.5/18	0.7/5.5	1.3	20	600	1	No	24 QFN	Yes	Yes ¹¹	Yes	Yes	No	No	Yes		1.95
TPS40101 ⁶	V	4.5/18	0.7/5.5	1.3	20	1000	1	No	24 QFN	Yes	Yes ¹¹	Yes	Yes	No	No	Yes		1.95
TPS40190	V	4.5/15	0.59/12.75	1.2	20	300	1	Yes	10 SON	No	Yes ¹¹	Yes	No	No	No	No		1.00
TPS40192/3	V	4.5/18	0.59/14.4	1.2	15/20	600/300	0.5	Yes	10 SON	Yes	Yes ¹¹	Yes	No	No	No	No		1.05
TPS40195 ⁷	V	4.5/20	0.59/17	1.2	20	Adj. to 600	0.5	Yes	16 TSSOP, 16 QFN	Yes	Yes ¹¹	Yes	Yes ⁷	No	No	No		1.50
TPS40200 ⁸	VFF	4.5/52	0.7/46	0.2	3	Adj. to 500	1	No ⁵	8 SOIC	No	No	No	Yes	No	No	No	H, A	0.75
TPS5124 ⁹ (dual output)	V	4.5/15	0.9/12	2	20	Adj. to 500	1	Yes	30 TSSOP	No	Yes	No	No	No	No	No		2.15
TPS51113/63	V	4.5/15	0.8/9.5	1.5	25	300/600	1	No	10 SON	Yes	Yes	Yes	No	No	No	No		0.99
TPS53114	D-CAP2	4.5/26	0.76/5.5	1.1	15	350/700	1	Yes	16 TSSOP, 16 HTSSOP	No	Yes	Yes	No	No	No	No		1.35
TPS53124 (dual output)	D-CAP	4.5/26	0.76/5.5	1.1	15	380	1	Yes	24 QFN, 28 TSSOP	No	Yes	Yes	No	No	No	No		1.95
TPS53125/26/27 (dual output)	D-CAP2	4.5/26	0.76/5.5	1.1	15	350/700		Yes	24 QFN, 24 TSSOP	No	Yes	Yes	No	No	No	No		2.35

¹V = voltage-mode control, VFF = voltage mode with voltage feed-forward compensation, and C = current-feedback control.

²Current levels of this magnitude can be supported with commonly available commercial FETs.

³The controller of choice for most applications will be the source/sink version, which has two-quadrant operation and will source or sink output current.

⁴DDR = Supports DDR memory.

⁵Drives high-side P-FET.

⁶Provides advanced startup sequencing and output voltage margining.

⁷Bidirectional 180° out-of-phase synchronization.

⁸Nonsynchronous, drives P-FETs.

⁹180° out of phase, dual outputs, overvoltage protection.

¹⁰Integrated voltage-doubler charge pump for higher drive voltage.

¹¹During soft start: source only.

[†]Devices qualified for HiRel (H) or Automotive (A) applications are available with different pricing. Certain voltage options are not available.

*Suggested resale price in U.S. dollars in quantities of 1,000.

→ DC/DC Controllers (External Switch)

Selection Guide (Continued)

All parts have soft start, short-circuit protection, and undervoltage lockout functions.

Device	Switched Outputs	Phases	V _{IN} (min/max) (V)	V _O (min/max) (V)	Driver Current (A)	Output Current (A) ¹	Frequency (kHz)	V _{REF} Tol (%)	Package(s)	Pwr Good	Overshoot Protection	Source & Sink ²	Pre-biased Operation	Ext Synch Pin	Remote Sense	Price*
Multiphase Synchronous DC/DC Buck Controllers																
TPS40090 ⁹	1	2 to 4	4.5/15	0.7/3.3	Var	30/phase	Adj. to 1000	1	24 TSSOP, 28 QFN	Yes	Yes	Yes	No	Yes	Yes	1.90
TPS40091 ¹⁰	1	2 to 4	4.5/15	0.7/3.3	Var	30/phase	Adj. to 1000	1	24 TSSOP, 28 QFN	Yes	Yes	Yes	No	Yes	Yes	1.90
TPS40131	1	2	1/40	0.7/5.8	1	50	Adj. to 1000	1	32 QFN	Yes	Yes	Yes	Yes	Yes	Yes	2.70
TPS40132	1	2	1/40	0.6/5.8	1	50	Adj. to 1000	0.8	32 QFN	Yes	Yes	Yes	Yes	Yes	Yes	2.95
TPS40140 ¹¹	1 or 2	1 or 2	2/40	0.7/5.8	1.2	25/phase	Adj. to 1000	0.5	36 QFN	Yes	Yes	Yes	Yes	Yes	Yes	3.05
TPS40180 ¹²	1	1	2/40	0.7/5.8	1.2	25	Adj. to 1000	0.75	24 QFN	Yes	Yes	Yes	Yes	Yes	Yes	2.05
TPS51727 ¹³	1	1 or 2	4.5/28	0.4/1.25	2.7	25/phase	Up to 500	1.5	40 QFN	Yes	Yes	Yes	No	No	No	1.80

Support Devices

TPS40120	6-bit digitally programmed feedback divider with VRM 10.x VID code table								14 TSSOP		0.49
----------	--	--	--	--	--	--	--	--	----------	--	------

Device	Switched Outputs	LDO Outputs	Phases	V _{IN} (min/max) (V)	V _O (min/max) (V)	Driver Current (A)	Output Current (A) ¹	Frequency (kHz)	V _{REF} Tol (%)	Control Method	Bootstrap Diode	Package(s)	Overshoot Protection	Pwr Good	DDR ³	HiRel (H) or Automotive (A) [†]	Price*
DC/DC Synchronous Buck Controllers with Light-Load Efficiency																	
TPS51020	2	1	1	4.5/28	0.85/5.5	2	20	270, 360, 450	1	Voltage	Yes	30 TSSOP	Yes	Yes	Yes		2.40
TPS5110	1	1	1	4.5/28	0.9/3.5	1.5	15	Up to 500	1	PWM	No	24 TSSOP	Yes	Yes	No		2.50
TPS51116 ¹⁴	1	1	1	3/28	1.5/3.0	0.8	10	Up to 400	1	Current, D-CAP	No	20 PwrPAD, 24 QFN	Yes	Yes	Yes		1.80
TPS51117 ¹⁴	1	0	1	1.8/28	0.75/5.5	3	10	Up to 550	1	D-CAP	Yes	14 TSSOP, 14 QFN	Yes	Yes	No		1.20
TPS51120/A TPS51121/2	2	2	1	4.5/28 4.5/32	2/5.5	3	20	270, 330, 430, 580	1	Current, D-CAP	No	32 QFN	Yes	Yes	No		2.50
TPS51124 ¹⁴	2	0	1	3/28	0.76/5.5	3	10	300, 360, 420	1	D-CAP	No	24 QFN	Yes	Yes	No		2.10
TPS51125	2	2	1	5.5/28	2/5.5	0.8/1.0	20	325	1	D-CAP	No	24 QFN	Yes	Yes	No		2.15
TPS51220	2	2	1	4.5/28	1/12	1.5	25	Adj. to 1000	1	Current, D-CAP	Yes	32 QFN	Yes	Yes	No		2.60
TPS5130	3	1	1	4.5/28	0.9/5.5	1.5	15	Up to 500	1.5	PWM	No	48 QFP	Yes	Yes	No	A	2.85
TPS51511 ¹⁴	1	1	1	3/28	0.75/3.3	0.8	10	Up to 550	1	Current, D-CAP	Yes	20 QFN	Yes	Yes	No		1.90
TPS51123	2	2	1	5.5/30	2/5.5	—	20	200 to 460	1	D-CAP	Yes	24 QFN	Yes	Yes	No		2.15
TPS51217/8 ¹⁵	1	0	1	3/30	0.7/26	—	20	290 to 430	0.5	D-CAP	Yes	10 SON	Yes	Yes	No		1.30
TPS51513 ¹⁶	1	0	1	3/30	0.7/1.05	8	27	250 to 500	0.5	D-CAP+	Yes	32 QFN	Yes	Yes	No		1.30
TPS51610/11	1	0	1	3/30	0.3/1.5	8	27	200 to 500	0.5	D-CAP+	Yes	32 QFN	Yes	Yes	No		1.50
TPS51620/21	1	0	2	3/30	0.3/1.5	8	54	250 to 500	0.5	D-CAP+	Yes	40 QFN	Yes	Yes	No		2.50

Device	Synch	Switched Outputs	LDO Outputs	V _{IN} (min/max) (V)	V _O (min/max) (V)	Driver Current (A)	Output Current (A) ¹	Frequency (kHz)	V _{REF} Tol (%)	Control Method	Bootstrap Diode	Package(s)	Pwr Good	DDR ³	Remote Sense	HiRel (H) or Automotive (A) [†]	Price*
Other Topology DC/DC Controllers																	
TPS40210/1 ¹⁷	No	1	0	4.5/52	5/250	0.8	6	Adj. to 1000	2	Current	No	10 MSSOP/SON	No	No	No	A	1.10
TPS43000 ¹⁸	Yes	1	0	1.8/9	0.8/8	1.2	6	Adj. to 2000	2	Voltage	No	16 TSSOP	No	No	No		2.25
TPS51100	No	0	1	4.75/5.25	0.6/1.7	—	3	—	Ext	LDO	No	10 PwrPAD	No	Yes	Yes		0.80
TPS51200	No	0	1	0.3/3.6	0.3/3.6	—	2	—	Ext	LDO	No	10 SON	Yes	Yes	Yes	A	0.90
TPS64200/1/2/3 ¹⁹	No	1	0	1.8/6.5	1.2/6.5	—	3	—	2	Hyster	No	23 SOT	No	No	No		0.55
UC3572	Flyback	1	0	4.75/30	0/-48	0.5	5	300	2	Voltage	No	8 DIL/SOIC	No	No	No		1.05

DC/DC Controllers Without Drivers

TL1451A	Buck, boost, flyback	2	0	3.6/50	2.5/50	0.02	3	Adj. to 500	4	Var	No	16 PDIP/SOIC/SO/SSOP/TSSOP	No	No	No	H	0.95
TL5001	Buck, boost, flyback	1	0	3.6/40	1/50	0.02	3	Adj. to 500	3	Var	No	8 PDIP/SO/SOIC	No	No	No	H, A	0.45

¹Current levels of this magnitude can be supported with commonly available commercial FETs.

²The controller of choice for most applications will be the source/sink version, which has two-quadrant operation and will source or sink output current.

³DDR = Supports DDR memory.

⁴Drives high-side P-FET.

⁵Provides startup sequencing.

⁶Available 180° out-of-phase synchronization.

⁷Nonsynchronous, drives P-FETs.

⁸180° out of phase, dual outputs, overvoltage protection.

⁹Binary outputs.

¹⁰Tri-state outputs.

¹¹Stackable to 16 phases.

¹²Stackable to 8 phases, reference is trimmable.

¹³D-CAP mode control, internal boot-strap diode.

¹⁴5-V bias required.

¹⁵Has dynamic output voltage-change capability, 340-kHz frequency.

¹⁶Custom 0.3- to 1.5-V output voltage range available. Contact TI factory.

¹⁷Overvoltage protection, source only.

¹⁸External synch pin.

¹⁹Drives high-side P-FET.

[†]Devices qualified for HiRel (H) or Automotive (A) applications are available with different pricing. Certain voltage options are not available.

*Suggested resale price in U.S. dollars in quantities of 1,000.

DC/DC Converters (Integrated Switch)



Design Factors

Efficiency and Solution Size — Use of inductive switching converters with integrated switches is recommended when highest conversion efficiency and smallest solution size are desired.

TI's family of low-power DC/DC converters (TPS6xxx) and SWIFT™ (TPS54xxx) point-of-load step-down DC/DC converters achieve 97% peak efficiencies. Synchronous rectification not only replaces the cost of an external Schottky rectifier diode but also increases the converter efficiency by up to 10%. Higher efficiency will directly translate into additional operating time in battery-powered applications and smaller power dissipation in high-current applications, easing thermal design.

Integrating the high- and low-side switching FETs reduces board space, as only resistors and capacitors along with

one inductor are required externally for operation. Depending on the output current, DC/DC converters come in packages such as CSP (1.2 A), SOT-23 (600 mA), QFN-10 (1.2 A) and TSSOP-28 (14 A), further reducing solution size.

Output Current — Output current is typically limited by the size of the integrated FETs and is rated for the minimum input voltage (end-of-discharge voltage in battery systems) for the TPS6xxx series. The TPS54xxx output current denotes the continuously available output current; higher peak-currents are achievable to ensure proper supply at start-up of high-performance DSP, FPGA and ASIC systems. For boost converters, the datasheet specifies the current limit of the built-in switches. A rough estimate of the output current can be obtained using the formula:

$$I_{OUT} = 0.65 \times I_{Switch(min)} \times (V_{IN}/V_{OUT})$$

For output currents below 300 mA and efficiencies under 90%, inductorless charge-pump DC/DC regulators can be a cost and space-efficient alternative (see pages 38–39).

Input Voltage — DC/DC converters can operate from a wide range of input sources: power modules, wall supplies or batteries. The TPS6xxx series with its small packaging and quiescent current is optimized for low-power, battery-operated applications. For battery-powered systems the input voltage changes over a wide range while the battery is being discharged. For this reason converter selection depends on the given battery technology and number of cells.

Output Voltage — Lower voltages are required for today's advanced DSPs, FPGAs and ASICs. To allow maximum flexibility, both fixed and adjustable output voltages down to 0.7 V are available.

18-V Input, 38-V Output Boost Converter

TPS61175

NEW

Get samples, datasheets, evaluation modules and application notes at: www.ti.com/sc/device/TPS61175

The TPS61175 is a monolithic switching regulator with integrated 3-A, 40-V power switch that supports input voltage from multicell batteries and from regulated 5-V, 12-V power rails. The device employs current-mode control architecture. The switching frequency can be set with an external resistor or synchronized to an external clock. The frequency is programmable from 200 kHz to 2.2 MHz to avoid critical frequencies when the application is noise sensitive.

Key Features

- Wide V_{IN} from 2.9 V to 18 V allows two or three Li-ion cell applications
- Support of 12-V industrial or automotive power rails
- Ideal for SEPIC or flyback configurations
- Enables high-power boost applications due to 3-A switch
- High-efficiency power conversion of up to 93%

- Switching frequency:
 - Programmable: 200 kHz to 2.2 MHz
 - Can synchronize to external clock
- Skip-mode switching cycle for output regulation at light loads which results in a higher efficiency across the complete load range
- User-defined soft start to limit inrush current during startup
- 14-pin HTSSOP package for best thermal behavior

Applications

- 5-V to 12-V and 24-V power conversion
- Boost/SEPIC/flyback configuration
- Lead-acid battery support
- ADSL modems
- TV tuner

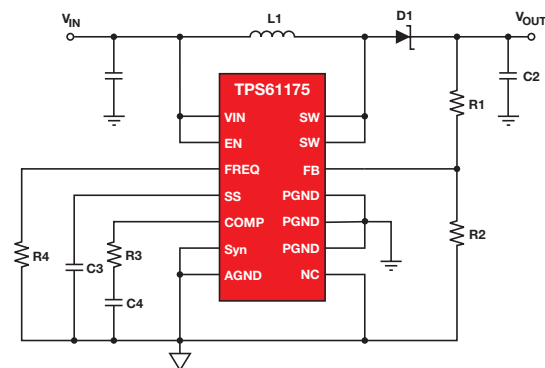

TPS61175 typical application.

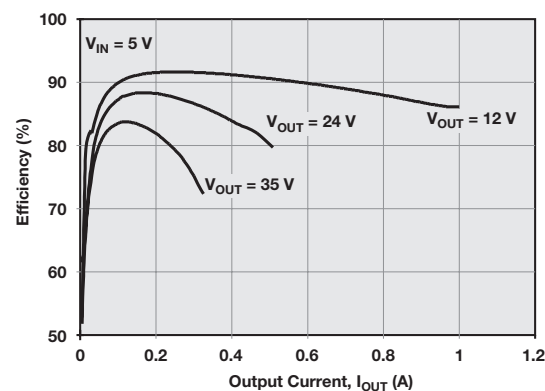

TPS61175 efficiency.

→ DC/DC Converters (Integrated Switch)

DC/DC Step-Down Converters (Integrated Switch) Family of Products

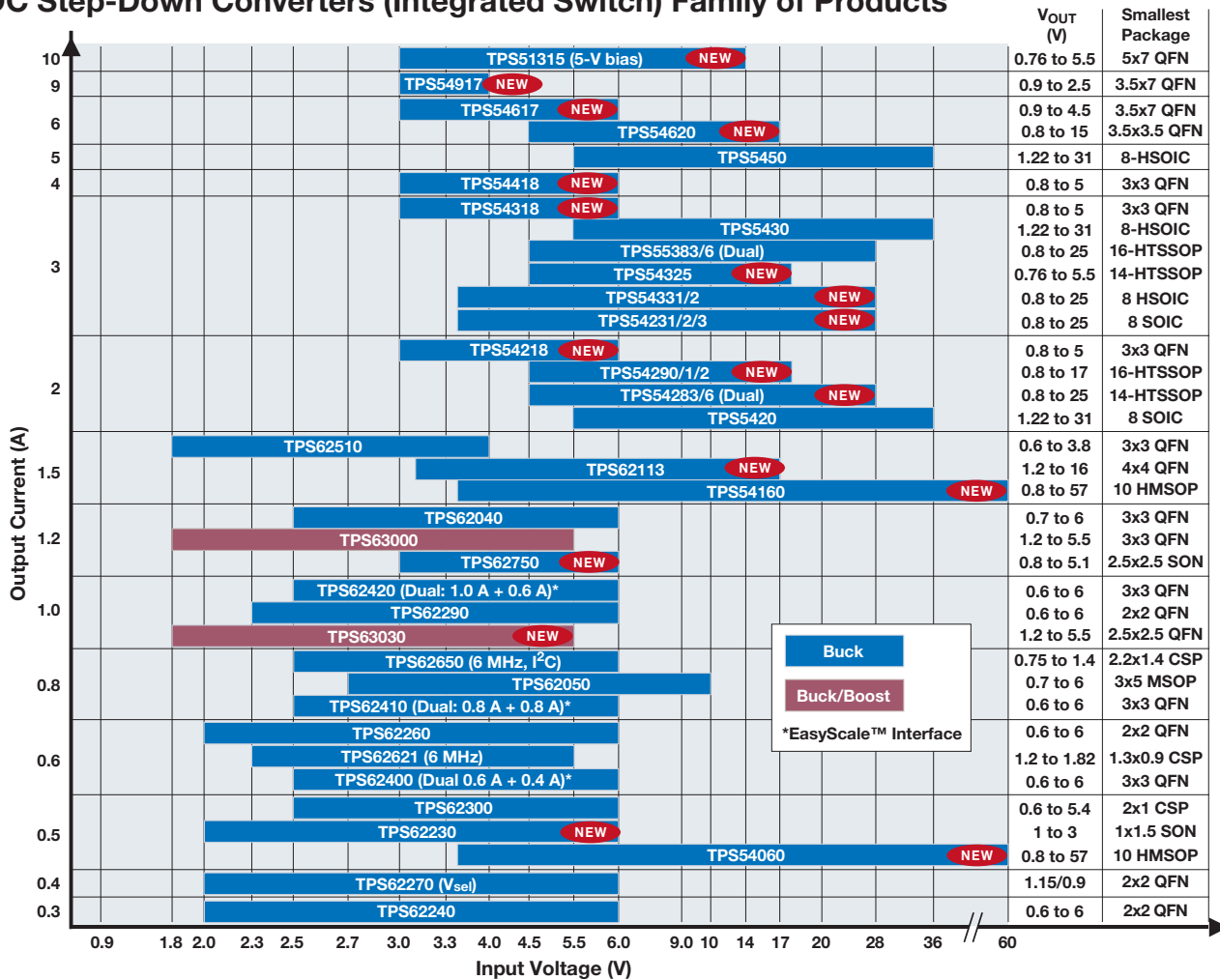

DC/DC Step-Up Converters (Integrated Switch) Family of Products

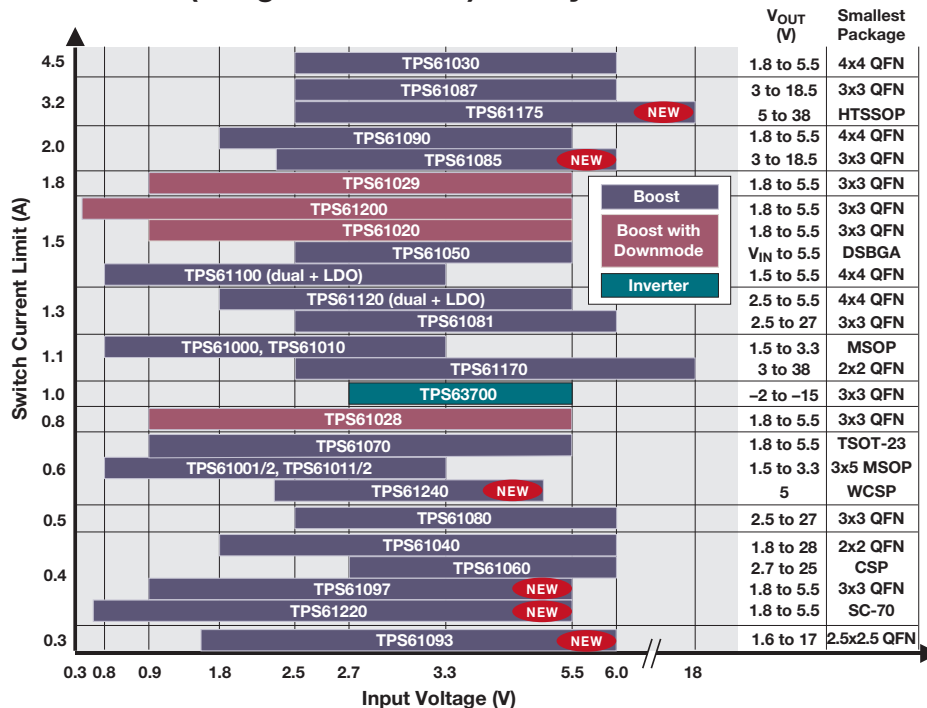

DC/DC Converters (Integrated Switch)



Selection Guide

Device	I _{OUT} (mA)	V _{IN} (V)	Min V _{OUT} (V)	Fixed V _{OUT} Options (V)	Max Duty Cycle (%)	Switching Frequency (kHz)	Features										EVM	Package(s)	Price*
							Power Good Pin	Sync Pin	180° Out-of-Phase Switching	Adj. Soft Start	Current Limit and Thermal Shutdown	Synchronous Buck	Light-Load Efficiency	Internal Compensation	Sequencing/Tracking	Active Bus Termination (DDR)			
SWIFT™ Step-Down (Buck) Regulators																			
TPS54040	500	3.5 to 42	0.8	—	98	100 to 2500	✓	✓		✓	✓		✓		✓	10 HMSOP	1.45		
TPS54060	500	3.5 to 60	0.8	—	98	100 to 2500	✓	✓		✓	✓		✓		✓	10 HMSOP	1.90		
TPS5410	1000	5.5 to 36	1.23	—	87	500					✓		✓		H, A	8 SOIC	1.60		
TL2575	1000	4.75 to 40	1.23	3.3, 5, 12, 15	93	52					✓		✓			5 TQ263/220, PDIP	1.31		
TL2575HV	1000	4.75 to 60	1.23	3.3, 5, 12, 15	93	52					✓		✓			5 TQ263/220, PDIP	1.98		
TPS54140	1500	3.5 to 42	0.8	—	98	100 to 2500	✓	✓		✓	✓		✓		A	10 HMSOP	1.90		
TPS54160	1500	3.5 to 60	0.8	—	98	100 to 2500	✓	✓		✓	✓		✓		A	10 HMSOP/QFN	2.10		
TPS54290/1/2 (dual)	1500/2500	4.5 to 18	0.8	—	90	300/600/1200			✓		✓		✓	✓		16 HTSSOP	2.95		
TPS40222	1600	4.5 to 8.0	0.8	—	90	1250				✓	✓		✓			6 SON	0.70		
TPS54218	2000	2.95 to 6.0	0.8	—	98	200 to 2000	✓	✓		✓	✓					16 QFN (3x3 mm)	1.50		
TPS54231/2/3	2000	3.5 to 28	0.8	—	93	570/1000/300				✓	✓		✓			8 SOIC	1.25		
TPS54225	2000	4.5 to 18	0.76	—	90	700	✓			✓	✓		✓			14 HTSSOP	1.45		
TPS54226	2000	4.5 to 18	0.76	—	90	700	✓			✓	✓		✓			14 HTSSOP	1.50		
TPS54283/6 (dual)	2000 each	4.5 to 28	0.8	—	90/85	300/600			✓		✓		✓	✓		14 HTSSOP	2.40		
TPS5420	2000	5.5 to 36	1.23	—	87	500					✓		✓		H, A	8 SOIC	1.70		
TPS54318	3000	2.95 to 6.0	0.8	—	98	200 to 2000	✓	✓		✓	✓					16 QFN (3x3 mm)	2.00		
TPS54310/1/2/3/4/5/6	3000	3.0 to 6.0	0.9	Adj., 0.9, 1.2, 1.5, 1.8, 2.5, 3.3	90	280 to 700	✓	✓ ¹		✓	✓		✓ ²		H, A	20 HTSSOP	2.25		
TPS54317	3000	3.0 to 6.0	0.9	—	90	280 to 1600	✓	✓		✓	✓					24 QFN	2.50		
TPS54372	3000	3.0 to 6.0	0.2	—	90	280 to 700	✓			✓	✓			✓	A	20 HTSSOP	2.25		
TPS54331	3000	3.5 to 28	0.8	—	93	570				✓	✓					8 SOIC	1.35		
TPS54325	3000	4.5 to 18	0.76	—	90	700	✓			✓	✓		✓			14 HTSSOP	1.55		
TPS54326	3000	4.5 to 18	0.76	—	90	700	✓			✓	✓		✓			14 HTSSOP	1.60		
TPS54350/2/3/4/5/6/7	3000	4.5 to 20	0.9	Adj., 1.2, 1.5, 1.8, 2.5, 3.3, 5	80	250 to 700	✓	✓	✓		✓		✓ ²		H	16 HTSSOP	1.85		
TPS5430	3000	5.5 to 36	1.23	—	87	500					✓		✓		H, A	8 HSOIC	1.85		
TPS54383/6 (dual)	3000 each	4.5 to 28	0.8	—	90/85	300/600			✓		✓		✓	✓		14 HTSSOP	2.65		
TPS55383/6 (dual)	3000 each	4.5 to 28	0.8	—	90/85	300/600			✓		✓		✓			16 HTSSOP	2.65		
TPS54332	3500	3.5 to 28	0.8	—	93	1000				✓	✓					8 HSOIC	1.40		
TPS54418	4000	2.95 to 6.0	0.8	—	98	200 to 2000	✓	✓		✓	✓					16 QFN (3x3 mm)	2.15		
TPS5450	5000	5.5 to 36	1.23	—	87	500					✓		✓		H, A	8 HSOIC	2.25		
TPS54610/1/2/3/4/5/6	6000	3.0 to 6.0	0.9	Adj., 1.2, 1.5, 1.8, 2.5, 3.3, 5	90	280 to 700	✓	✓ ¹		✓	✓		✓ ²		H, A	28 HTSSOP	3.20		
TPS54617	6000	3.0 to 6.0	0.9	—	90	280 to 1600	✓	✓		✓	✓					34 QFN (3.5x7 mm)	3.30		
TPS54672	6000	3.0 to 6.0	0.2	—	90	280 to 700	✓			✓	✓			✓		28 HTSSOP	3.20		
TPS54620	6000	4.5 to 17	0.8	—	98	200 to 1600	✓	✓		✓	✓		✓			QFN (3.5x3.5 mm)	1.95		
TPS54910	9000	3.0 to 4.0	0.9	—	90	280 to 700	✓	✓		✓	✓					28 HTSSOP	3.65		
TPS54972	9000	3.0 to 4.0	0.2	—	90	280 to 700	✓			✓	✓			✓		28 HTSSOP	3.65		
TPS51315	10000	3 to 14 ³	0.76	—	100	100 to 1000				✓	✓	✓	✓			QFN (5x7 mm)	2.65		
TPS54010	14000	2.25 to 4.0	0.9	—	90	280 to 700	✓	✓		✓	✓					28 HTSSOP	4.25		

¹Fixed V_{OUT} options do not have a sync pin.

²Adjustable versions are externally compensated.

³Requires 4.5- to 5.5-V bias input.

[†]Devices qualified for HiRel (H) or Automotive (A) applications are available with different pricing. Certain voltage options are not available.

*Suggested resale price in U.S. dollars in quantities of 1,000.

New devices are listed in bold red.

 **DC/DC Converters (Integrated Switch)**
Selection Guide (Continued)

Device	I _{OUT} (mA)	Switch Current Limit (typ) (mA)	V _{IN} (V)	V _{OUT} Adj. (V)	V _{OUT} Fixed (V)	Peak Efficiency (%)	Switching Frequency (typ) (kHz)	Recommended Inductor Size (µH)	Quiescent Current (typ) (µA)	Shutdown Current (typ) (µA)	Low Battery	Power Good	Undervoltage Lockout	Thermal and/or Short-Circuit Protection	Package(s)				EVM	HiRel (H) or Automotive (A) [†]	Price*	
															Chipscale (WCSP)	SOT-23	MSOP	QFN				SOIC
Low-Power Step-Down (Buck) Regulators — Small, Efficient, Low I_q																						
TPS62200	300	670	2.5 to 6.0	0.7 to 6.0	—	95	1000	10	15	0.1			✓	✓		6				✓	A	0.75
TPS62201/2/3/4	300	670	2.5 to 6.0	—	1.5/1.8/3.3/1.6	95	1000	10	15	0.1			✓	✓		6					A	0.75
TPS62205/7/8	300	670	2.5 to 6.0	—	2.5/1.2/1.875	95	1000	10	15	0.1			✓	✓		6					A	0.75
TPS62240	300	700	2.0 to 6.0	0.6 to 6.0	—	95	2250	2.2	15	0.1			✓	✓		5		6		✓		0.90
TPS62242/3	300	700	2.0 to 6.0	—	1.2/1.8	95	2250	2.2	15	0.1			✓	✓				6				0.90
TPS62220	400	880	2.5 to 6.0	0.7 to 6.0	—	95	1250	4.7	15	0.1			✓	✓		6				✓		0.85
TPS62221/2/3/4/5	400	880	2.5 to 6.0	—	1.5/1.8/2.3/1.6/2.2	95	1250	4.7	15	0.1			✓	✓		6						0.85
TPS62228/9	400	880	2.5 to 6.0	—	1.875/1.7	95	1250	4.7	15	0.1			✓	✓		6						0.85
TPS62270/2/3	400	700	2.0 to 6.0	—	1.15/0.9-3.3/ 2.1-3.3/2.5	95	2250	2.2	15	0.1			✓	✓				6		✓		0.95
TPS62400	400 + 600	800/1000	2.5 to 6.0	0.6 to 6.0	—	95	2250	2 x 3.3	30	0.1								10		✓		1.15
TPS62401/2	400 + 600	800/1000	2.5 to 6.0	—	1.1/1.575, 1.2/1.895	95	2250	2 x 3.3	30	0.1								10				1.15
TPS62230/1/2/3/4/8/9	500	840	2.05 to 6	—	2.5/1.8/1.2/2.25/1.0	94	3000	1	22	0.1			✓	✓				6		✓		0.45
TPS62320	500	740	2.5 to 6.0	0.6 to 5.4	—	90	3000	1	86	0.1			✓	✓		8		10				1.20
TPS62321	500	740	2.5 to 6.0	—	1.5	93	3000	1	86	0.1			✓	✓		8		10				1.20
TPS62260	600	1000	2.0 to 6.0	0.6 to 6.0	—	95	2.25	2.2	15	0.1			✓	✓		5		6		✓	A	0.95
TPS62261/2	600	1000	2.0 to 6.0	—	1.2/1.8	95	2.25	2.2	15	0.1			✓	✓				6				0.95
TPS62560/1	600	1000	2.5 to 5.5	0.85 to 5.5	—	95	2.25	2.2	15	0.1			✓	✓		5		6		✓		0.65
TPS62562	600	1000	2.5 to 5.5	—	1.8	95	2.25	2.2	15	0.1			✓	✓				6				0.65
TPS62620/1/2/4	600	1100	2.3 to 5.5	—	1.82/1.8/1.5/1.2	90	6000	0.47	31	0.2			✓	✓		6						0.85
TPS62420	600 + 1000	1000/1400	2.6 to 6.0	0.6 to 6.0	—	95	2250	2 x 3.3	30	0.1								10		✓		1.20
TPS62700	650	1100	2.5 to 6.0	1.3 to 3.09	—	90	2000	3.3	10	0.01			✓	✓		8				✓		1.00
TPS62250	700	1000	2.0 to 6.0	0.6 to 6.0	—	95	2250	2.2	15	0.1			✓	✓				6				1.00
TPS62350	800	1300	2.7 to 6.0	0.75 to 1.5375	—	88	3000	1.0	30	0.1			✓	✓		12		10		✓		1.00
TPS62050/1	800	1400	2.7 to 10.0	0.7 to 6.0	—	95	850	10	12	1.5	✓	✓	✓	✓				10		✓		1.60
TPS62052/4/6	800	1400	2.7 to 10.0	—	1.5/1.8/3.3	95	850	10	12	1.5	✓	✓	✓	✓				10		✓		1.60
TPS62351/2/3/4/5	800	1500	2.7 to 6.0	0.75 to 1.975	—	88	3000	1.0	30	0.1			✓	✓		12		10		✓		1.00
TPS62410	800 + 800	1200/1200	2.6 to 6.0	0.6 to 6.0	—	95	2250	2 x 3.3	30	0.1								10				1.20
TPS62650	800	1500	2.3 to 5.5	0.75 to 1.4375	—	86	6000	0.47	38	0.5			✓	✓	✓							1.05
TPS62290	1000	1400	2.3 to 6.0	0.6 to 6.0	—	95	2.25	2.2	15	0.1			✓	✓				6		✓		1.15
TPS62291/3	1000	1400	2.3 to 6.0	—	3.3/1.8	95	2.25	2.2	15	0.1			✓	✓				6				1.15
TPS62590	1000	1400	2.5 to 5.5	0.75 to 5.5	—	95	2.25	2.2	15	0.1			✓	✓				6		✓		0.80
TPS63000	1200	1800	1.8 to 5.5	1.2 to 5.5	—	96	1500	2.2	30	0.1			✓	✓				10		✓		2.00
TPS63001/2	1200	1800	1.8 to 5.5	—	3.3/5	96	1500	2.2	30	0.1			✓	✓				10			A	2.00
TPS62040	1200	2000	2.5 to 6.0	0.7 to 6.0	—	95	1250	6.2	18	0.1			✓	✓				10	10	✓		1.40
TPS62042/3/4/6	1200	2000	2.5 to 6.0	—	1.5/1.6/1.8/3.3	95	1250	6.2	18	0.1			✓	✓				10	10		A	1.40
TPS62750	1300	2400	2.9 to 6	1.5 to 5.1	—	92	2250	2.2	0.78 mA	0.3			✓	✓				10		✓		1.20
TPS62510	1500	2000	1.8 to 3.8	0.6 to 3.8	—	97	1500	2.2	18	0.1								10		✓		1.55
TPS62110	1500	2400	3.1 to 17	1.2 to 16	—	95	1000	6.8	18	1.5	✓	✓	✓	✓				16		✓	H	1.30
TPS62111/2/3	1500	2400	3.1 to 17	—	3.3/5	95	1000	6.8	18	1.5	✓	✓	✓	✓				16		✓	H	1.30
TPS62060	1600	2700	2.3 to 6.0	0.6 to 6.0	—	94	3000	1.0	18	0.1			✓	✓				8		✓		1.35
TPS62065	2000	3300	2.3 to 6.0	0.6 to 6.0	—	94	3000	1.0	18	0.1			✓	✓				8		✓		1.55

[†] Devices qualified for HiRel (H) or Automotive (A) applications are available with different pricing.

Certain voltage options are not available.

*Suggested resale price in U.S. dollars in quantities of 1,000. *Suggested resale price in U.S. dollars in quantities of 1,000.

New devices are listed in **bold red**.
Preview devices are listed in **bold blue**.

DC/DC Converters (Integrated Switch)



Selection Guide (Continued)

Device	I _{OUT} (mA) ¹	Switch Current Limit (typ) (mA)	V _{IN} (V)	V _{OUT} Adj. (V)	V _{OUT} Fixed (V)	Peak Efficiency (%)	Switching Frequency (typ) (kHz)	Recommended Inductor Size (μH)	Quiescent Current (typ) (μA)	Shutdown Current (typ) (μA)	Integrated LDO I _{OUT} (mA)/V _{OUT} (V)	Low Battery	Power Good	Undervoltage Lockout	Thermal and/or Short-Circuit Protection	Package(s)					EVM	HiRel (H) or Automotive (A) [†]	Price*		
																WCGSP (Chip scale)	SOT-23	MSOP	QFN	TSSOP				SOIC	
Step-Up Regulators — Up to 6-A Switch Limit																									
TPS61220	50	400	0.7 to 5.5	1.8 to 5.5	—	95	—	4.7	5.5	0.2	—			✓	✓							✓		0.65	
TPS61221/2	50	400	0.7 to 5.5	—	3.3/5	95	—	4.7	5.5	0.2	—			✓	✓							✓		0.65	
TPS61041	50	250	1.8 to 6.0	V _{IN} to 28	—	87	1000	10	28	0.1	—			✓	✓			5				✓	A	0.65	
TPS61040	90	400	1.8 to 6.0	V _{IN} to 28	—	87	1000	10	28	0.1	—			✓	✓			5				✓	A	0.70	
TPS61042/3/5	100	500	1.8 to 6.0	V _{IN} to 28	—	85	1000	4.7	35	1	—			✓	✓					8		✓		0.75	
TPS61011/2/3	100	480/560/930	0.8 to 3.3	—	1.5/1.8/2.5	95	500	10	36	1	—	✓		✓	✓					10					1.10
TL497A	—	500	4.5 to 12	(V _{IN} + 2) to 30	—	85	—	—	11 mA	6000	—			✓	✓						14	14			0.86
TPS61001/2/3	100	500/650/900	0.8 to 3.3	—	1.5/1.8/2.5	85	500	33	50	0.2	—	✓		✓	✓					10					0.95
TPS61097-33	150	350	0.9 to 5.5	—	3.3	90	—	10	4	0.005	—			✓	✓			5		6					0.80
TPS61080	—	500	2.5 to 6.0	V _{IN} to 27	—	87	1200	4.7	—	—	—			✓	✓					10		✓			1.35
TPS61004/5/6	200	950/1000/1100	0.8 to 3.3	—	2.8/3/3.3	85	500	33	50	0.2	—	✓		✓	✓					10					0.95
TPS61014/5/6	200	1010/1060/1130	0.8 to 3.3	—	2.8/3/3.3	95	500	10	36	1	—	✓		✓	✓					10					1.10
TPS61000	200	1100	0.8 to 3.3	1.5 to 3.3	—	85	500	33	50	0.2	—	✓		✓	✓					10			✓		0.95
TPS61010	200	1130	0.8 to 3.3	1.5 to 3.3	—	95	500	10	36	1	—	✓		✓	✓					10			✓		1.10
TPS61028	200	800	0.9 to 5.5	1.8 to 5.5	—	96	720	6.8	25	0.1	—	✓		✓	✓					10			✓		0.85
TPS61070/1/2/3	250	700	0.9 to 5.5	1.8 to 5.5	—	90	1200 ²	4.7	19	1	—			✓	✓			6							0.80
TPS61093	300	1.1	1.6 to 6	V _{IN} to 17	—	88	1200	10	0.9 mA	1	—			✓	✓					10			✓		1.45
TPS61081	450	1200	2.5 to 6.0	V _{IN} to 27	—	87	1200	4.7	—	—	—			✓	✓					6			✓		1.45
TPS61240	450	600	2.3 to 5.5	—	5	90	3500	1	30	1.5	—			✓	✓			6		6			✓		0.80
TPS61241	450	700	2.3 to 5.5	—	5	90	3500	1	30	1.5	—			✓	✓			6					✓		0.80
TPS61170	500	1200	3.0 to 18	V _{IN} to 38	—	93	1200	10	—	1	—			✓	✓										1.40
TPS61020	500	1500	0.9 to 5.5	1.8 to 5.5	—	96	720	6.8	25	0.1	—	✓		✓	✓					10			✓		0.95
TPS61024/5/7	500	1500	0.9 to 5.5	1.8 to 5.5	3/3/3/5	96	720	6.8	25	0.1	—	✓		✓	✓					10					0.95
TPS61026/9	600	1800	0.9 to 5.5	1.8 to 5.5	—	96	720	6.8	25	0.1	—	✓		✓	✓					10			✓		1.10
TPS61090	700	2200	1.8 to 5.5	1.8 to 5.5	—	96	600	6.8	20	0.1	—	✓		✓	✓					16			✓		1.70
TPS61091/2	700	2000	1.8 to 5.5	—	3.3/5	96	600	6.8	20	0.1	—	✓		✓	✓					16			✓		1.70
MC34063A	750	1500	3 to 40	3 to 39.5	—	—	100	—	—	1	—			✓	✓					8		8	✓		0.21
TPS61200	800	1500	0.3 to 5.5	0 to V _{IN}	—	90	1250	2.2	50	1	—			✓	✓					10			✓		1.10
TPS61201/2	800	1500	0.3 to 5.5	0 to V _{IN}	3.3/5	90	1250	2.2	50	1	—			✓	✓					10			✓		1.10
TPS61030	1000	4500	1.8 to 5.5	1.8 to 5.5	—	96	600	6.8	20	0.1	—	✓		✓	✓					16	16		✓		2.10
TPS61031/2	1000	4500	1.8 to 5.5	—	3.3/5	96	600	6.8	20	0.1	—	✓		✓	✓					16	16		✓		2.10
TPS61175	1300	3800	2.9 to 18	V _{IN} to 38	—	95	2200	10	—	<1.5	—			✓	✓					14			✓		1.80
Step-Up (Boost) Regulators with Integrated LDO (Dual Output)																									
TL499A	100	—	1.1 to 10	2.9 to 30	—	85	—	—	—	15	100/Adj.			✓	✓							8			1.08
TPS61100	200	1500	0.8 to 3.3	1.5 to 5.5	—	95	500	10	65	0.5	120/Adj.	✓	✓	✓	✓					24	20		✓		1.50
TPS61103/6/7	200	1500	0.8 to 3.3	—	3.3/3.3/3.3	95	500	10	65	0.5	120/Adj., 1.5, 1.8	✓	✓	✓	✓					24	20				1.50
TPS61120	500	1300	1.8 to 5.5	2.5 to 5.5	—	95	500	10	40	0.2	200/Adj.	✓	✓	✓	✓					16	16		✓		1.65
TPS61121/2	500	1300	1.8 to 5.5	—	3.3/3.6	95	500	10	40	0.2	200/1.5, 3.3	✓	✓	✓	✓					16	16				1.65
Buck-Boost Regulators																									
TPS61130	300	1300	1.8 to 5.5	2.5 to 5.5	—	90	500	10	40	0.2	200/Adj.	✓	✓		✓					16	16		✓		1.55
TPS61131/2	300	1300	1.8 to 5.5	—	3.3/3.3	90	500	10	40	0.2	200/1.5, 3.3	✓	✓		✓					16	16				1.55
TPS63030/31	800	1000	1.8 to 5.5	1.2 to 5.5	3.3	96	2400	1.5	25	0.1	—			✓	✓					10			✓		1.20
TPS63000/1/2	1200	1800	1.8 to 5.5	1.2 to 5.5	3.3/5.0	90	1800	2.2	30	0.1	—			✓	✓					10			✓	A	1.50
TPS63010/11/12	1200	2200	2 to 5.5	1.2 to 5.5	3.3/3.4/2.8/2.9	96	2600	1.5	30	0.1	—			✓	✓			20					✓		1.50
Inverting Regulators																									
TL497A	—	500	4.5 to 12	-1.2 to -25	—	85	—	—	11 mA	6000	—										14	14			0.86
TPS63700	360	1000	2.7 to 5.5	-2 to -15	—	84	1400	4.7	—	0.014	—									10			✓		1.65
MC34063A	750	1500	3 to 38	-1.25 to -36.3	—	—	100	—	0.330 mA	—	—			✓	✓					8		8	✓		0.21
TPS5430	1500	4000	5.5 to 36	-1.23 to -31	—	87	500	15	4.4 mA	50	—			✓	✓							8	✓	H, A	1.85

¹For boost converters, max. I_{OUT} can be estimated with 0.65 x switch limit x (V_{OUT}/V_{OUT}).

²PWM/PPM (TPS61070); PWM only (TPS61071).

[†]Devices qualified for HiRel (H) or Automotive (A) applications are available with different pricing. Certain voltage options are not available.

*Suggested resale price in U.S. dollars in quantities of 1,000.

New devices are listed in bold red.

→ Inductorless DC/DC Regulators (Charge Pumps)

Design Factors

Efficiency and Solution Size — Use of charge pumps is recommended when a tradeoff between efficiency and solution size needs to be made. Higher efficiency will directly translate into additional operating time in battery-powered applications. Charge pumps achieve peak efficiencies of 90% and typically require only a few capacitors for operation. No inductors, diodes or FETs are needed. Charge pumps come in small packages such as SOT-23 and MSOP-8, which further reduce solution size.

Output Current — Charge pump converters allow for small, power-efficient and cost-effective DC/DC solutions with output currents less than 300 mA and output voltage less than 6 V. If larger output currents, higher output voltages or greater efficiency are required, use of an inductive switching converter is more cost- and space-efficient (pages 31–37).

Output Ripple and Noise — TI charge pumps reduce output voltage ripple to a minimum by operating a pair of integrated charge pump loops with a phase shift of 180 degrees. This helps to avoid the cost of additional filtering at the output. Charge pumps also tend to generate less noise than an equivalent inductive switching converter of equal output current rating. This may be important in RF-sensitive or low-noise applications.

Inductorless DC/DC Regulators (Charge Pumps) Family of Products

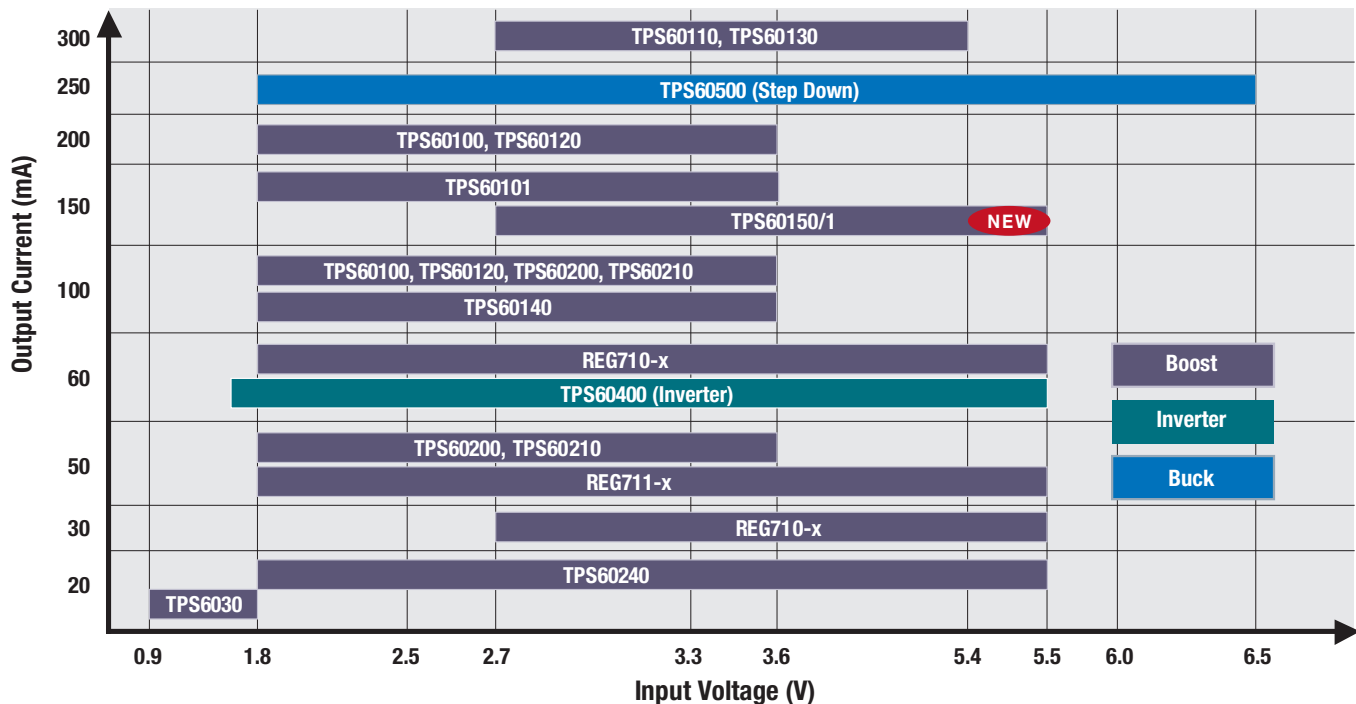

For a complete list of Resources, visit: power.ti.com

Inductorless DC/DC Regulators (Charge Pumps)



Selection Guide

Device	I _{OUT} (mA)	V _{IN} (V)	V _{OUT} Adj. (V)	V _{OUT} Fixed (V)	Efficiency (%)	Switching Frequency (max) (kHz)	Quiescent Current (typ) (μA)	Shutdown Current (typ) (μA)	Features						Package(s)				EVM	HiRel (H) or Automotive (A) [†]	Price*
									Shutdown	Low Battery	Power Good	Undervoltage Lockout	Current Limit	Thermal Limit	SOT-23	QFN	MSOP	TSSOP			
Step-Down (Buck) Regulators																					
TPS60500	250	1.8 to 6.5	0.8 to 3.3	—	90	1200	40	0.05	✓		✓	✓	✓	✓			10		✓	0.80	
TPS60501	250	1.8 to 6.5	—	3.3	90	1200	40	0.05	✓		✓	✓	✓	✓			10			0.80	
TPS60502	250	1.8 to 6.5	—	1.8	90	1200	40	0.05	✓		✓	✓	✓	✓			10			0.80	
TPS60503	250	1.8 to 6.5	—	1.5	90	1200	40	0.05	✓		✓	✓	✓	✓			10			0.80	
Boost Regulators																					
TPS60100	200	1.8 to 3.6	—	3.3	90	300	50	0.05	✓			✓	✓				20	✓		0.90	
TPS60101	100	1.8 to 3.6	—	3.3	90	300	50	0.05	✓			✓	✓				20			0.80	
TPS60110	300	2.7 to 5.4	—	5.0	90	300	60	0.05	✓			✓	✓				20	✓		0.95	
TPS60111	150	2.7 to 5.4	—	5.0	90	300	60	0.05	✓			✓	✓				20			0.85	
TPS60120/1	200	1.8 to 3.6	—	3.3	85	450	55	0.05	✓	✓ ¹	✓ ¹	✓	✓				20	✓		0.90	
TPS60122/3	100	1.8 to 3.6	—	3.3	85	450	55	0.05	✓	✓ ¹	✓ ¹	✓	✓				20			0.80	
TPS60124/5	200	1.8 to 3.6	—	3.0	85	450	55	0.05	✓	✓ ¹	✓ ¹	✓	✓				20			0.90	
TPS60130/1	300	2.7 to 5.4	—	5.0	90	450	60	0.05	✓	✓ ¹	✓ ¹	✓	✓				20	✓		0.95	
TPS60132/3	150	2.7 to 5.4	—	5.0	90	450	60	0.05	✓	✓ ¹	✓ ¹	✓	✓				20			0.95	
TPS60140/1	100	1.8 to 3.6	—	5.0	70	450	65	0.05	✓	✓ ¹	✓ ¹	✓	✓				20	✓		0.80	
TPS60150	140	2.7 to 5.5	—	5.0	90	1500	4.7	0.01	✓					✓		6		✓		0.55	
TPS60200/1	100	1.8 to 3.6	—	3.3	90	400	40	0.05	✓	✓ ¹	✓ ¹	✓	✓			10		✓		0.80	
TPS60202/3	50	1.8 to 3.6	—	3.3	90	400	40	0.05	✓	✓ ¹	✓ ¹	✓	✓			10				0.70	
TPS60204/5	100	1.8 to 3.6	—	3.3	90	400	35	0.05	✓	✓ ¹	✓ ¹	✓	✓			10				0.80	
TPS60210/1	100	1.8 to 3.6	—	3.3	90	400	35	2	Snooze	✓ ¹	✓ ¹	✓	✓			10		✓		0.80	
TPS60212/3	50	1.8 to 3.6	—	3.3	90	400	35	2	Snooze	✓ ¹	✓ ¹	✓	✓			10				0.70	
TPS60230/1	125	2.7 to 6.5	—	5.5 ²	85	1250	160	0.1	✓			✓	✓	✓		16		✓		0.55	
TPS60240	12	1.8 to 5.5	—	3.3	90	160	250	0.1					✓	✓		8				0.60	
TPS60241	12	2.7 to 5.5	—	5.0	90	160	250	0.1					✓	✓		8		✓		0.60	
TPS60242	12	1.8 to 5.5	—	3.0	90	160	250	0.1					✓	✓		8				0.60	
TPS60243	12	1.8 to 5.5	—	2.7	90	160	250	0.1					✓	✓		8				0.60	
TPS60300/2	20	0.9 to 1.8	—	3.3	90	900	35	1	✓			✓ ³	✓			10		✓		0.75	
TPS60301/3	20	0.9 to 1.8	—	3.0	90	900	35	1	✓			✓ ³	✓			10				0.75	
TPS60310/2	20	0.9 to 1.8	—	3.3	90	900	35	2	Snooze			✓ ³	✓			10				0.70	
TPS60311/3	20	0.9 to 1.8	—	3.0	90	900	35	2	Snooze			✓ ³	✓			10				0.70	
TL7660	20	1.5 to 10	—	< 2 V _{IN}	99	10.35	80	—							8	8				0.72	
Buck-Boost Regulators																					
REG710-2.5	30	1.8 to 5.5	—	2.5	90	1000	65	0.01	✓				✓	✓	6					0.50	
REG710-2.7	30	1.8 to 5.5	—	2.7	90	1000	65	0.01	✓				✓	✓	6					0.50	
REG710-3	30	1.8 to 5.5	—	3.0	90	1000	65	0.01	✓				✓	✓	6					0.50	
REG710-3.3	30	1.8 to 5.5	—	3.3	90	1000	65	0.01	✓				✓	✓	6			✓		0.50	
REG71050	60	2.7 to 5.5	—	5.0 ²	90	1000	65	0.01	✓				✓	✓	6			✓		0.55	
REG710-5	60	2.7 to 5.5	—	5.0 ²	90	1000	65	0.01	✓				✓	✓	6			✓		0.50	
REG71055	60	3.0 to 5.5	—	5.5 ²	90	1000	65	0.01	✓				✓	✓	6				A	0.55	
REG711-2.5	50	1.8 to 5.5	—	2.5	90	1000	60	0.01	✓				✓	✓		8				0.65	
REG711-2.7	50	1.8 to 5.5	—	2.7	90	1000	60	0.01	✓				✓	✓		8				0.65	
REG711-3	50	1.8 to 5.5	—	3.0	90	1000	60	0.01	✓				✓	✓		8				0.65	
REG711-3.3	50	1.8 to 5.5	—	3.3	90	1000	60	0.01	✓				✓	✓		8				0.65	
REG711-5	50	2.7 to 5.5	—	5.0	90	1000	60	0.01	✓				✓	✓		8				0.65	
Inverting Regulators																					
LT1054	100	3.5 to 15	—	-5.0	—	25	2500	100	✓									✓	A	1.44	
TPS60400	60	1.6 to 5.5	-(1.6 to 5.5)	—	99	50 to 250	125	—							5			✓	A	0.35	
TPS60401	60	1.6 to 5.5	-(1.6 to 5.5)	—	99	28	65	—							5				A	0.35	
TPS60402	60	1.6 to 5.5	-(1.6 to 5.5)	—	99	70	120	—							5				A	0.35	
TPS60403	60	1.6 to 5.5	-(1.6 to 5.5)	—	99	300	425	—							5				A	0.35	

¹Features apply respectively to device numbers shown. For example, only the TPS60120 has the Low Battery feature and only the TPS60121 has the Power Good feature.

²White LED driver.

³Feature applies only to second device shown. For example, only the TPS60302 has the Power Good feature.

[†]Devices qualified for HiRel (H) or Automotive (A) applications are available with different pricing.

*Suggested resale price in U.S. dollars in quantities of 1,000.

New devices are listed in bold red.

→ Power Management Units

Design Factors

Efficiency and External Component Count

— Integrated power conversion devices typically feature a combination of different power converters ranging from LDOs to charge pumps and inductive DC/DC regulators. Multiple LDO devices may offer the most channels and least external components per given package size but are least efficient. Devices with several inductive DC/DC converters require a larger package and external inductors, but they typically provide the best conversion efficiency and longest battery life for portable applications.

Package — Due to the integration level, power dissipation capability needs to be taken into consideration. Most packages for highly integrated devices have a thermal pad at the bottom for optimal thermal performance.

Dynamic Voltage Scaling (DVS)

— DVS is a feature typically used in power-management units (PMUs) and DC/DC converters that power DSPs and other processors. This feature allows the system controller to change the output voltage of the converter when needed. In portable applications, every micro-ampere of either ground current or leakage current saved adds up to enhanced

battery life. Scaling down the voltage applied to the processor reduces the leakage current. Reducing the applied voltage also helps to run the microprocessor under lowered clock frequencies, thereby saving valuable battery power during idle or sleep mode. Devices with an I²C interface allow DVS by changing the output voltages of the converters and LDOs on the fly, achieving significant dynamic power savings. Devices with logic high/low levels allow DVS by using a dedicated pin of the DC/DC converter. This pin needs to be connected to a

logic high or logic low level from the processor's GPIO to set the output voltage of the DC/DC accordingly.

Integration Level — Application-specific power management devices offer different levels of integration and address specific power needs of the end equipment. They may feature building blocks such as chargers, linear regulators, DC/DC controllers or DC/DC converters. Some devices also integrate specific communication interfaces such as I²C to control voltages and other functions.

Analog Companion with USB and Audio

TPS65950

NEW

Get samples, datasheets, evaluation modules and app reports at:

www.ti.com/sc/device/TPS65950

Optimized for OMAP3503/15/25/30 family. Analog companion IC integrating power, stereo audio codec, high-speed USB 2.0 OTG, battery charger and other functions in a small 7x7-mm BGA package.

Family options:

- TPS65950: charger, audio, USB 2.0 OTG, DCDC, LDO
- TPS65930: audio, USB 2.0 OTG, DCDC, LDO
- TPS65920: USB 2.0 OTG, DCDC, LDO

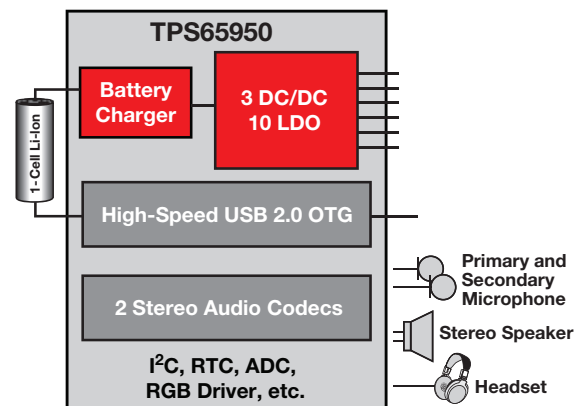

PMU with All Power for Portable Applications

TPS65070

NEW

Get samples and datasheets at: www.ti.com/sc/device/TPS65070

General-purpose PMU integrating a linear battery charger with dynamic power-path management (DPPM), three step-down converters, two general-purpose LDOs, a touch-screen controller and a WLED boost converter (up to 2x 10 LEDs). Internal and external sequencing. Available for different processors in a small 6x6-mm QFN package.

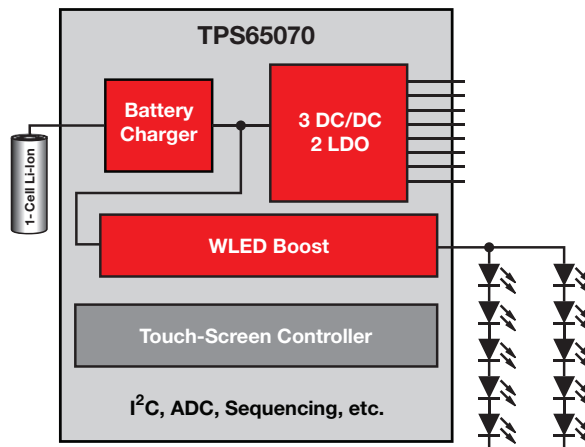



Selection Guide

Device	V _{IN} (V)	No. of Regulator Outputs	Charger	Audio Codec	USB 2.0 OTG Transceiver	WLED Boost	DCDC Step-Down Converter	DCDC Step-Down Controller	LDO	Communication Interface	Description	Package	HiRel (H) or Automotive (A) [†]	Price*
Power Management for Consumer, Industrial and Other Applications														
TPS65200	2.5 to 6.5	0	Li-Ion			✓	—	—	—	i ² C	With current shunt monitor	WCSP-36		2.35
TPS65720/1	4.3 to 28	2	Li-Ion				1	—	1	i ² C	Bluetooth headsets and other apps. Also QFN	WCSP-25		1.65
TPS65000/1	1.8 to 6.0	3	—				1	—	2	—	General purpose. TPS65001 with supervisor	QFN-16		1.40
TPS75003	2.2 to 6.5	3	—				—	2	1	—	PMU for FPGA, DSP and ASIC	QFN-20	H	2.05
TPS65705	3.3 to 6	3	—				2	—	1	—	General purpose	WCSP-16		1.35
TPS65230/1	10.8 to 22	3	—				2	1	—	i ² C	With two 0.5A or 1A USB switches. For STB apps.	HTSSOP-48		2.80
TPS65232	10.8 to 22	3	—				2	1	—	—	Wide input voltage range. Also TSSOP package.	QFN-40		2.45
TPS65010/1/2/3/4	2.5 to 20.0	4	Li-Ion				2	—	2	i ² C	General purpose PMU with charger	QFN-48		2.55
TPS65053/8	2.5 to 6.0	5	—				2	—	3	—	Low-cost	QFN-24		1.85
TPS65070/3	4.3 to 17	5	Li-Ion			✓	3	—	2	i ² C	With touchscreen controller.	QFN-48		3.95
TPS65020/1/2	2.5 to 6.0	6	—				3	—	3	i ² C	PMU with high-current DCDC	QFN-40		3.05
TPS65023	2.5 to 6.0	6	—				3	—	3	i ² C	PMU for OMAP and other processors	QFN-40	A	3.30
TPS650240/1/2/3/4/5	2.5 to 6.0	6	—				3	—	3	Logic H/L	General purpose, with logic high/low voltage scaling	QFN-32	A	2.95
TPS650250	2.5 to 6.0	6	—				3	—	3	—	All Vout externally adjustable	QFN-32		2.95
TPS65050/1/2/4/6	2.5 to 6.0	6	—				2	—	4	Logic H/L	General purpose	QFN-32		1.95
TPS65920	2.7 to 4.5	7	—		✓		3	—	4	2x i ² C	Optimized for OMAP35x processors	BGA-139		4.50
TPS65930	2.7 to 4.5	7	—	✓	✓		3	—	4	2x i ² C	Optimized for OMAP35x processors	BGA-139		5.95
TPS65950	2.7 to 4.5	13	Li-Ion	✓	✓		3	—	10	2x i ² C	Optimized for OMAP35x processors	BGA-209		8.15
TPS658600/10/20	4.3 to 16.5	14	Li-Ion			✓	3	—	11	i ² C	Optimized for nvidia processors	BGA-121		6.95
Integrated Power Management for Digital Still Cameras														
TPS65510	2.6 to 5.5	5	—			✓	—	—	4	—	Battery backup with boost converter	QFN-16		1.50
TPS65530	1.5 to 5.5	9	—				7	1	1	—	9-channel DC/DC	QFN-48		4.20
TPS65520	1.5 to 5.0	13	—				7	1	5	—	13-channel DC/DC + LDO	BGA-121		4.95

[†]Devices qualified for HiRel (H) or Automotive (A) applications are available with different pricing.

*Suggested resale price in U.S. dollars in quantities of 1,000.

New devices are listed in **bold red**.

Preview devices are listed in **bold blue**.

DSPs and Other Processors Supported by TI Power-Management Units (PMUs)

Processor	Part Number	PMU
TI	DM320	TPS65021
	DM335/DM355/DM365	TPS65053
	DM357	TPS65023
	DM365	TPS65510 + TPS65530A, TPS65053
	DM643x	TPS650243
	DM644x	TPS65023
	OMAP3503/15/25/30	TPS65950/30/20, TPS65073, TPS650731, TPS65023
	AM3505/17	TPS650732, TPS65023
	OMAP-L1xx	TPS65070, TPS65023
	C2834x	TPS650061
	C6742/6/8	TPS65070, TPS65023
	C6745/7	TPS65023
Freescale	IMX27	TPS65053
	IMX31	TPS650240
	IMX35	TPS650250
Marvell	PXA270	TPS65021/2
Nvidia	APX2500/ 2600	TPS658600
	Tegra 600/ 650	TPS658610/20
RMI	AU1200/ 1300	TPS65021
Samsung	S3C2410/2/3	TPS65051/2
	S3C2440/2	TPS65056
	S3C2443-400MHz	TPS650240
	S3C2443-533MHz	TPS650241
	S3C6400-533MHz	TPS650245
Sif	S3C6410	TPS650240, TPS65074
	TITAN 2	TPS650244
	ATLAS 4	TPS65072

Reference designs for these TI processor families are available online. Bookmark these pages and check often to find new designs for the latest DSP and microprocessor generations. PMU solutions with and without battery charger:

www.ti.com/pmu

TI power-management reference designs:

www.ti.com/processorpower

→ LED Lighting Controller

LED Lighting Power Controller

UCC28810, UCC28811

Get samples, datasheets and evaluation modules at: www.ti.com/sc/device/UCC28810 or [UCC28811](http://www.ti.com/sc/device/UCC28811)

The UCC28810 and UCC28811 are general-lighting power controllers for low- to medium-power applications that require power-factor correction and EMC compliance. The devices can control a flyback, buck or boost converter operating in critical-conduction mode.

Features

- Transition-mode controller for low-cost, AC-input LED lighting applications
- Implements single-stage power-factor-corrected LED driver
- Enhanced transient response with slew-rate comparator
- Interfaces with traditional wall dimmers

Applications

- AC-input, general-lighting applications using high-brightness LEDs
- Industrial, commercial and residential lighting fixtures
- Outdoor lighting: Street, roadway, parking, construction and ornamental LED lighting fixtures

Reference Designs

Device	Description
UCC28810EVM-001	25-W, 700-mA PFC from universal AC flyback LED driver
UCC28810EVM-002	100-W, 0.9-A PFC from universal AC LED driver
UCC28810EVM-003	Multi-transformer current-sharing universal AC LED driver

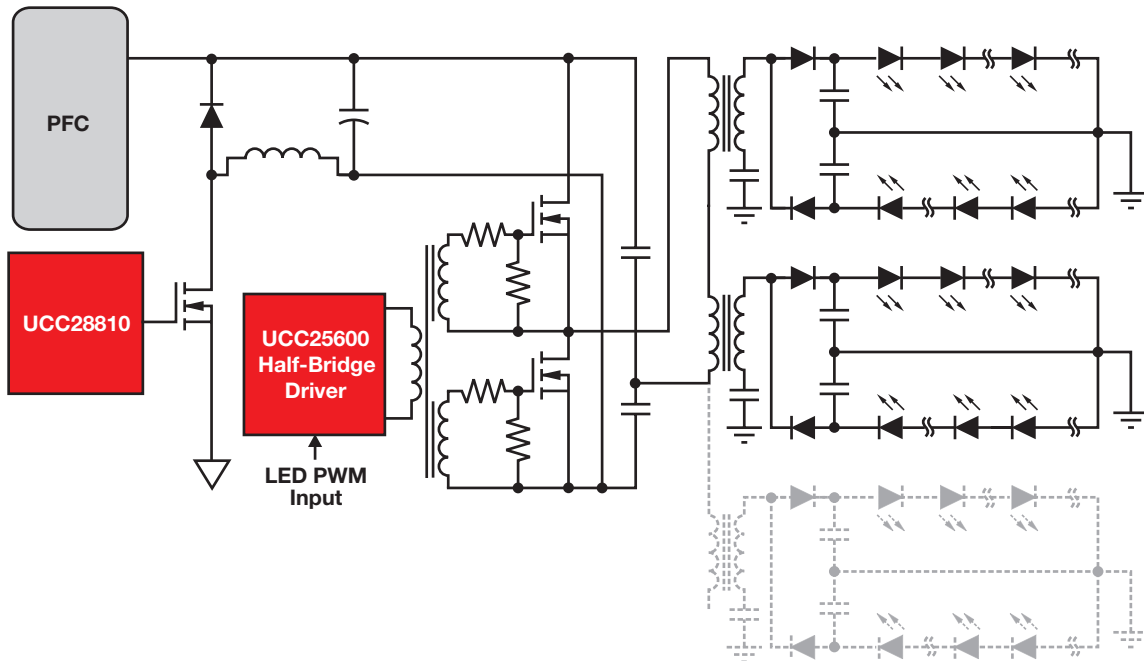

For a complete LED solutions and reference designs, visit: www.ti.com/led

White LED Backlight, High-Current LED and LED Flashlight Drivers



Design Factors

Series or Parallel LED Configuration

— Drives the driver topology. Inductive boost converters provide the necessary high voltage to a series LED string. This requires only one current regulation loop and two connection points for the LED string.

Charge pumps typically drive parallel LEDs; but unless each LED is current-regulated, each leg requires a current-set resistor.

Current Regulation — Avoids brightness variations in LED strings or legs that consist of LEDs with different forward voltages (V_f).

Overvoltage Protection (OVP)

— Protects the inductive driver from destruction in case faulty LEDs open the LED string.

Dimming — LED drivers typically feature analog and/or digital dimming to adjust the LED brightness.

LED and OLED Drivers Function Guide

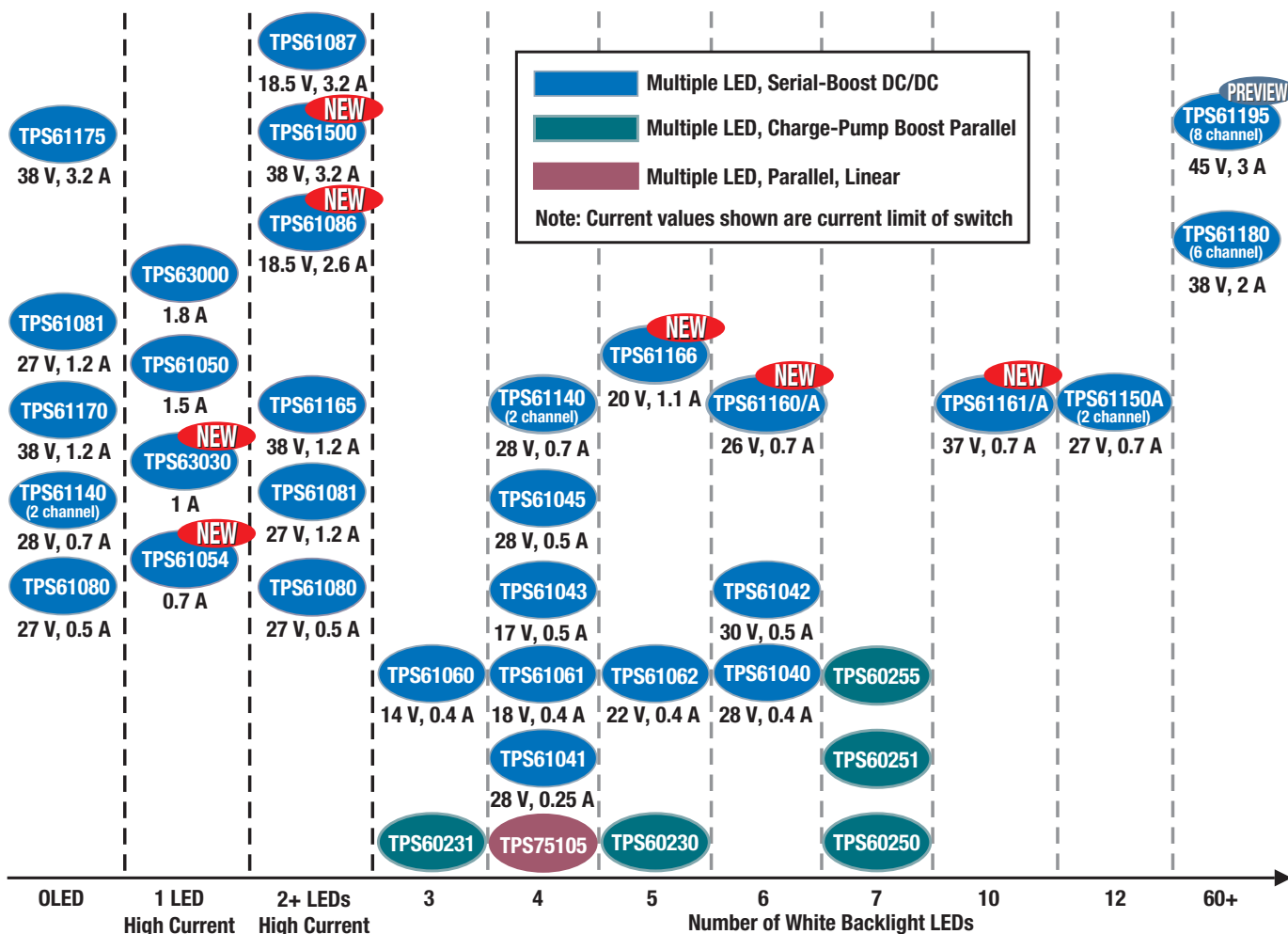

→ White LED Backlight, High-Current LED and LED Flashlight Drivers

Selection Guide

Device	V _{IN} (V)	Synchronous	Type	Number of LEDs ¹	OLED Capable	LED Configuration	Switch Current Limit (typ) (mA)	Current Regulation	Overvoltage Protection (min) (V)	Output Capacitor	Load-Disconnect During Shutdown	Dimming ²	Peak Efficiency ³ (%)	Quiescent Current (typ) (mA)	Shutdown Current (typ) (µA)	Package(s)	HiRel (H) or Automotive (A) [†]	Price*
LED Backlighting																		
TPS61041	1.8 to 6.0	No	Inductive	4	No	Series	250	No	No	1 µF	No	Yes	85	0.028	0.1	SOT-23	A	0.65
TPS61040	1.8 to 6.0	No	Inductive	6	No	Series	400	No	No	1 µF	No	Yes	86	0.028	0.1	SOT-23	A	0.65
TPS61043	1.8 to 6.0	No	Inductive	4	No	Series	400	Yes	17	100 nF	Yes	Yes	85	0.038	0.1	QFN-8		0.71
TPS61042	1.8 to 6.0	No	Inductive	6	No	Series	500	Yes	28	100 nF	Yes	Yes	85	0.038	0.1	QFN-8		0.75
TPS61045	1.8 to 6.0	No	Inductive	6	Yes	Series	500	Yes	28	100 nF	Yes	Yes	85	0.038	0.1	QFN-8		0.90
TPS61140	2.5 to 6.0	Yes	Inductive	4 + 1 OLED	Yes	2 Series	2 x 550	Yes	28	—	No	1-pin	82	2	1.5	QFN-10		1.16
TPS61150A	2.5 to 6.0	Yes	Inductive	Up to 2 x 6	No	2 Series	2 x 550	Yes	28	—	No	1-pin	83	2	1.9	QFN-10		1.16
TPS61166	2.5 to 6.0	Yes	Inductive	5	No	Series	1100 ⁴	Yes	19	4.7 µF	Yes	Yes		1.5	1	QFN-10		1.35
TPS61160	2.7 to 18	No	Inductive	6	No	Series	700	Yes	26	1 µF	No	1-pin	90	1.8	1	QFN-6		0.72
TPS61160A	2.7 to 18	No	Inductive	6	No	Series	700	Yes	26	1 µF	No	Yes	90	1.8	1	QFN-6		0.72
TPS61161	2.7 to 18	No	Inductive	10	No	Series	700	Yes	38	1 µF	No	1-pin	90	1.8	1	QFN-6	A	0.76
TPS61161A	2.7 to 18	No	Inductive	10	No	Series	700	Yes	38	1 µF	No	Yes	90	1.8	1	QFN-6		0.76
TPS61165	3.0 to 18	No	Inductive	10 to 40	No	Series	1200	Yes	38	1 µF	No	1-pin	90	2.3	1	QFN-6		1.10
TPS61060	2.7 to 6.0	Yes	Inductive	3	No	Series	400	Yes	14	220 nF	Yes	Yes	83	—	1	QFN-8/WCSP-8		0.85
TPS61061	2.7 to 6.0	Yes	Inductive	4	No	Series	400	Yes	18	220 nF	Yes	Yes	82	—	1	QFN-8/WCSP-8		0.90
TPS61062	2.7 to 6.0	Yes	Inductive	5	No	Series	400	Yes	22	220 nF	Yes	Yes	81	—	1	QFN-8/WCSP-8		0.97
TPS61500	2.9 to 18	No	Inductive	8	No	Series	3000	Yes	35	4.7 µF	No	Yes	93	—	—	TSSOP-14		1.60
REG71050	3.2 to 5.5	—	Charge pump	3	No	Parallel	—	No	—	2.2 µF	—	No	92	0.065	0.01	SOT-23		0.55
TPS60230/1	2.7 to 6.5	—	Charge pump	5, 3	No	Parallel	—	Yes	—	1 µF	—	Yes	85	0.200	0.1	QFN-16		0.55
TPS60250/5	2.7 to 6.0	—	Charge pump	7	No	Parallel	—	Yes	—	4.7 µF	—	i ² C	—	6.7	1.3	QFN-16		0.90
TPS60251	2.7 to 6.0	—	Charge pump	7 + Aux	No	Parallel	—	Yes	—	4.7 µF	—	i ² C	—	6.7	1.3	QFN-24		0.90
TPS75103/5	2.7 to 5.5	—	LDO	2 or 4	No	Parallel	—	Yes	—	—	—	Yes	—	0.18	0.1	WCSP-9		0.65
TCA6507	1.65 to 3.6	—	Parallel	7	No	Parallel	—	—	—	—	—	—	—	—	—	WCSP-12/QFN-12		0.80
High-Current LED Driver																		
TPS61058/9	2.7 to 5.5	Yes	Inductive	1	No	Series	1100	No	No	3 x 22 µF	Yes	—	5.5	—	0.1	QFN-10		0.80
TPS61050/2	2.5 to 6.0	Yes	Inductive	1	No	Series	2000	Yes	No	10 µF	Yes	i ² C	90	8.50	1	QFN-10/WCSP-12		0.95
TPS61054/55	2.5 to 6.0	Yes	Inductive	1	No	Series	2000	Yes		10 µF	Yes	Yes	90	8.50	0.3	QFN-10/WCSP-12		0.90
TPS61080/1	2.5 to 6.0	No	Inductive	7	Yes	Series	700/1300	No	27	4.7 µF	Yes	No	94	1	1	QFN-10		1.35
TPS61180/1/2	5 to 24	No	Inductive	10 x 6	No	6 Series	2000	Yes	38	4.7 pF	No	Yes	93	1	2	QFN-16		1.90

¹More LEDs can be driven in parallel string configuration.

²May be via ENABLE pin, CONTROL pin or analog feedback network.

³Depends on LED current, input voltage, number of LEDs, ILED pin.

⁴Output current is limited to 300 mA.

[†]Devices qualified for HiRel (H) or Automotive (A) applications are available with different pricing.

*Suggested resale price in U.S. dollars in quantities of 1,000.

New devices are listed in **bold red**.
Preview devices are listed in **bold blue**.

LED Display Drivers



Design Factors

Dot Correction — Creates uniform LED brightness. Gives the ability to dynamically control the output current.

Grayscale — Provides an enhanced color spectrum per LED equivalent with the number of grayscale steps available.

Output Voltage Monitor — Monitors voltages at constant current output terminals to detect LED failure and short circuit.

LED Open Detection — Indicates a broken or disconnected LED at an output terminal.

Thermal Error Flag — Indicates an overtemperature condition.

Watchdog Timer — Turns output off when scan signal is stopped.

Thermal Shutdown — Turns output off when junction temperature exceeds its limit.

24-Channel, 12-Bit PWM LED Driver with 7-Bit Dot Correction TLC5951

Get samples, datasheets, evaluation modules and app reports at:

www.ti.com/sc/device/TLC5951

The TLC5951 is a 24-channel, constant-current sink driver. Each channel has individually adjustable, 4096-step (12-bit), pulse width modulation (PWM) grayscale brightness control and 128-step (7-bit), constant-current dot correction. The output channels are grouped into three groups of eight channels, and each channel group has 256-step (8-bit) global brightness control.

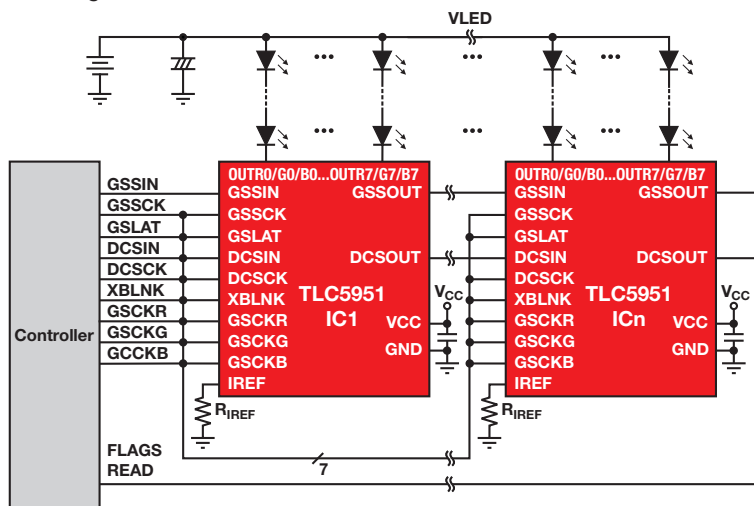

LED Display Drivers Function Guide

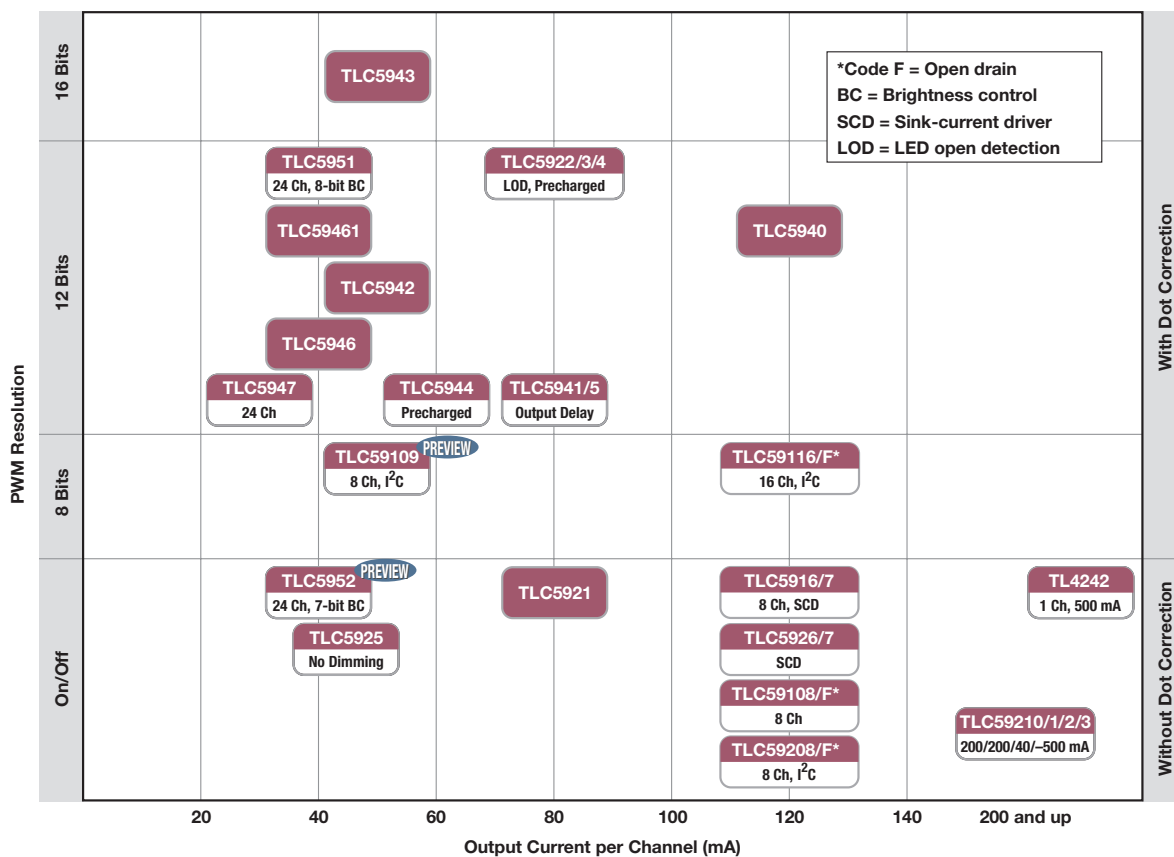

 LED Display Drivers

Selection Guide

Device	No. of Chan.	V _{IN} Min (V)	V _{IN} Max (V)	Output Current I _{LED} (mA)	Channel-to-Channel Accuracy (%)	Dev.-to-Dev. Accuracy (%)	Recharged FET	Short Detection	Open Detection	Overtemperature Detection	Brightness Control (Bits)	Dot Correction (Bits)	PWM Grayscale Control (Bits)	Comments	HiRel (H) or Automotive (A) [†]	Price*
TL4242	1	4.5	42	500	—	—		✓	✓	✓						0.65
TLC5916	8	3.3	5.5	120	±3 (Max)	±6 (Max)			✓	✓	8				A	0.35
TLC5917	8	3.3	5.5	120	±3 (Max)	±6 (Max)		✓	✓	✓	8				A	0.35
TLC59108	8	3	5.5	100	±3 (Max)	—			✓	✓	8		8	Constant-current output, I ² C		0.595
TLC59108F	8	3	5.5	100	±3 (Max)	—			✓	✓	8		8	Open-drain output, I ² C		0.595
TLC59208F	8	3	5.5	50	±3 (Max)	—			✓	✓	8		8	Open-drain output but changes the I ² C addressing capability, I ² C		0.63
TLC59116	16	3	5.5	100	±6 (Max)	—			✓	✓	8		8	Constant-current output, I ² C		0.735
TLC59116F	16	3	5.5	100	±6 (Max)	—			✓	✓	8		8	Open-drain output, I ² C		0.735
TLC59210	8	3	5.5	200	—	—								Clear function and clock pin for data latch		0.525
TLC59211	8	3	5.5	200	—	—								No clear function and clock pin for data latch		0.49
TLC59212	8	3	5.5	40	—	—										0.49
TLC59213/A	8	3	5.5	−500	—	—								"A" version has 15 ns (non-"A" is 25 ns)		0.525
TLC5921	16	4.5	5.5	80	±1	±4 (Max)			✓	✓						0.525
TLC5922	16	3	5.5	80	±1	±4							7			0.735
TLC5923	16	3	5.5	80	±1	±4			✓	✓			7			1.19
TLC5924	16	3	5.5	80	±1	±4	✓		✓	✓			7			0.805
TLC5925	16	3.3	5	45	±4 (Max)	±6 (Max)				✓						0.63
TLC5926	16	3	5.5	120	±6 (Max)	±6 (Max)			✓	✓	8				A	0.56
TLC5927	16	3	5.5	120	±6 (Max)	±6 (Max)		✓	✓	✓	8				A	0.735
TLC5928	16	3	5.5	35	±1	±1			✓	✓						0.595
TLC5930	12	3	3.6	40	±1	—				✓	6	8	10			1.085
TLC5940	16	3	5.5	120	±1	±2			✓	✓			6	12		0.98
TLC5941	16	3	5.5	80	±1	±2			✓	✓			6	12	A	0.875
TLC5942	16	3	5.5	50	±1.5	±3			✓	✓			7	12		0.84
TLC5943	16	3	5.5	50	±1.5	±3		✓	✓	✓	7		16			0.945
TLC5944	16	3	5.5	60	±1	±3	✓	✓	✓	✓			6	12		0.525
TLC5945	16	3	5.5	80	±1	±2			✓	✓			6	12		0.805
TLC5946	16	3	5.5	40	±1	±2			✓	✓			6	12		0.875
TLC59461	16	3	5.5	40	±1	±2			✓	✓			6	12	No auto-off function	0.875
TLC5947	24	3	5.5	30	±2	±2				✓			12	30-V V _{LED} , internal oscillator		0.525
TLC5951	24	3	5.5	40	±1.5	±3		✓	✓	✓	8	7	12, 10, 8			1.575
TLC5952	24	3	5.5	35	±1	±3		✓	✓	✓	7					0.64

[†] Devices qualified for HiRel (H) or Automotive (A) applications are available with different pricing.

*Suggested resale price in U.S. dollars in quantities of 1,000.



Simplified LCD Bias-Power Application

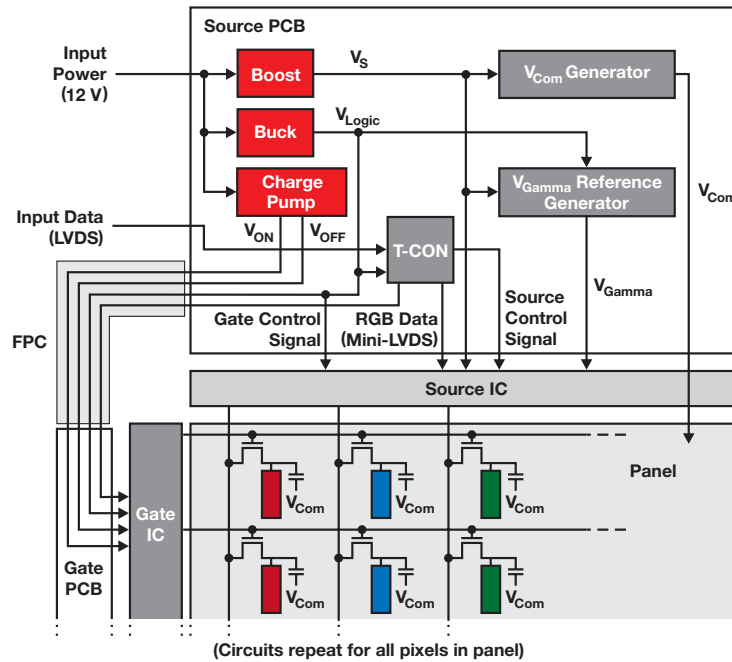

Selection Guide

Device	V _{IN} (V)	Boost I _{Limit} (min) (A)	Buck I _{Limit} (min) (A)	Features ¹							Price*
				Isolation Switch	V _{GH}	V _{GL}	GVS	V _{Com}	HVS	Other	
Solutions for Large LCDs (TVs)											
TPS61087	5	3.2	—	—	External	External	—	—	—	—	1.60
TPS65160/A	12	2.8	2	External	Driver	Driver	—	—	—	—	2.14
TPS65161	12	2.8	2.3	External	Driver	Driver	—	—	—	—	2.78
TPS65161A	12	3.7	2.3	External	Driver	Driver	—	—	—	—	2.78
TPS65161B	12	3.7	2.5	External	Driver	Driver	—	—	—	—	2.78
TPS65162	12	2.8	2.8	Integrated	Driver	Driver	Yes	2 op amps	—	—	2.45
TPS65163	12	2.8	2.5	External	External regulator	External regulator	Yes	—	—	9-ch level shifter, LCD discharge, reset generator	2.32
TPS65166	12	4.2	2.6	External	External regulator	Inverting buck-boost	—	—	AV _{DD}	Shunt regulator VGL2	1.53
TPS65167	12	3.5	2.5	External	Integrated	Driver	Yes	—	AV _{DD} , V _{GH}	LDO logic, controller, temp sensor	2.10
TPS65167A	12	3.5	2.5	External	Integrated	Driver	Yes	—	AV _{DD}	LDO logic, controller, temp sensor	2.10

Device	V _{IN} (V)	Boost I _{Limit} (min) (A)	Features ¹								HiRel (H) or Automotive (A) [†]	Price*
			Overvoltage Protection	Isolation Switch	V _{Logic}	V _{GH}	V _{GL}	GVS	V _{Com}	HVS		
Solutions for Medium LCDs (Monitors)												
TPS61085	5	2	Yes	—	—	External	External	—	—	—	—	0.95
TPS61087	5	3.2	Yes	—	—	External	External	—	—	—	—	1.60
TPS65100	5	1.6	Yes	—	LDO controller	Integrated	Driver	—	1 buffer	—	A	1.87
TPS65101	5	1.6	Yes	—	LDO controller	Integrated	Driver	—	1 buffer	—	—	1.87
TPS65105	5	0.96	Yes	—	LDO controller	Integrated	Driver	—	1 buffer	—	—	1.87
TPS65140	5	1.6	Yes	—	LDO controller	Integrated	Driver	—	—	—	A	1.71
TPS65141	5	1.6	Yes	—	LDO controller	Integrated	Driver	—	—	—	—	1.71
TPS65145	5	0.96	Yes	—	LDO controller	Integrated	Driver	—	—	—	A	1.71
TPS65150	5	2	Yes	External	—	Driver	Driver	Yes	1 buffer	—	—	1.92
TPS65165	5	4.4	Yes	—	—	Integrated	Driver	Yes	2 op amps, 1 buffer	AV _{DD} , V _{GH}	—	1.80

[†]V_{GH} = Positive LCD rail voltage, V_{GL} = Negative LCD rail voltage, GVS = Gate-voltage shaping for V_{GH}, V_{Com} = LCD V_{Com} voltage source, and HVS = High-voltage stress-test control.

[†]Devices qualified for HiRel (H) or Automotive (A) applications are available with different pricing. *Suggested resale price in U.S. dollars in quantities of 1,000.

→ LCD Bias Power

Selection Guide (Continued)

Device	V _{IN} (V)	Boost I _{Limit} (min) (A)	Features ¹								HiRel (H) or Automotive (A) [†]	Price*
			Overvoltage Protection	Isolation Switch	I _{Logic}	V _{GH}	V _{GL}	GVS	V _{Com}	Other		
Solutions for Small LCDs (Notebooks)												
TPS61085	2.3 to 6	2	Yes	—	—	External	External	—	—			0.95
TPS61087	2.5 to 6	3.2	Yes	—	—	External	External	—	—			1.60
TPS65100	2.7 to 5.8	1.6	Yes	—	LDO controller	Integrated	Driver	—	1 buffer		A	1.87
TPS65101	2.7 to 5.8	1.6	Yes	—	LDO controller	Integrated	Driver	—	1 buffer			1.87
TPS65105	2.7 to 5.8	0.96	Yes	—	LDO controller	Integrated	Driver	—	1 buffer			1.87
TPS65140	2.7 to 5.8	1.6	Yes	—	LDO controller	Integrated	Driver	—	—		A	1.71
TPS65141	2.7 to 5.8	1.6	Yes	—	LDO controller	Integrated	Driver	—	—			1.71
TPS65145	2.7 to 5.8	0.96	Yes	—	LDO controller	Integrated	Driver	—	—		A	1.71
TPS65150	1.8 to 6	2	Yes	External	—	Driver	Driver	Yes	1 buffer			1.92
TPS65146	2.5 to 6	2	Yes	—	LDO	Driver	External	Yes	1 buffer	LDO for gamma, reset (/XAO), LCD discharge		1.80

¹V_{GH} = Positive LCD rail voltage, V_{GL} = Negative LCD rail voltage, GVS = Gate-voltage shaping for V_{GH} and V_{Com} = LCD V_{Com} voltage source.

[†]Devices qualified for HiRel (H) or Automotive (A) applications are available with different pricing.

*Suggested resale price in U.S. dollars in quantities of 1,000.

Multichannel Bias Power for E-Paper Display

TPS65180

The TPS65180 is a power management IC that is ideal for powering an electronic paper display (EPD). In addition to the bias supplies required by the display drivers and timing controller, the IC also supports display temperature sensing.

Features

- 3- to 6-V input voltage range
- Positive charge-pump driver (VDDH): +22 V at 10 mA
- Negative charge-pump driver (VEE): -20 V at 12 mA
- Two adjustable LDOs
 - +15 V at 120 mA (Default output VPOS)
 - -15 V at 120 mA (Default output VNEG)
 - VPOS + VNEG = ±50 mV
- Adjustable VCOM driver
 - 0 to -2.75 V
 - 8-bit resolution
 - 15-A (max) integrated switch
- Integrated temperature sensor
- Packaging: 7x7-mm QFN

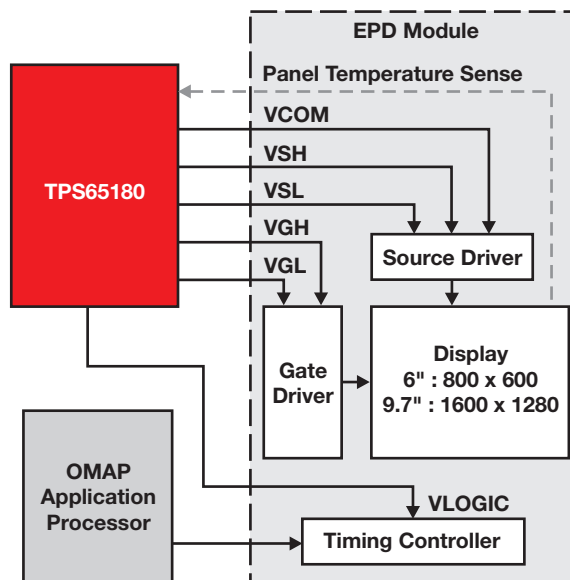

Photoflash Capacitor Chargers and Xenon Flashlight Drivers



Design Factors

Transformer — The output voltage of the converter is set by the turns ratio of the flyback transformer. The switching frequency is determined by the primary inductance of the flyback transformer. These two factors, along with the necessary voltage rating of the secondary, are key requirements for selecting the transformer.

Flash Capacitor — The flash capacitor must be rated for photoflash applications. The flash capacitor usually has low inductance in order to handle the surge currents during a flash. Capacitors not rated for photoflash applications will have a short lifespan in this application.

IGBT — Look for a photoflash rating when selecting an IGBT used to trigger the flash tube. There are several IGBTs that can withstand the voltage and surge currents associated with the flash; however, they usually come in a very large package since these ratings are for continuous duty. The photoflash-rated IGBT has the same ratings but comes in a small package since the loads are all surge and not continuous.

Flash Tube — Selection of a flash tube is based on several system-level considerations such as desired light spectrum, physical size, mounting method, trigger method, required light power, flash frequency, flash voltage, encapsulation

material and tube coatings. Customers should determine which lamp to select for their specific applications.

Trigger Transformer — Selection of the trigger transformer should be performed once a lamp has been selected. Each

lamp has a specific trigger energy needed to initiate a flash.

Efficiency — The efficiency of the converter is greatly impacted by the recovery time of the high-voltage diode. The faster the diode, the better the efficiency.

Integrated Photoflash Charger and IGBT Driver

TPS65552A

Get samples, datasheets, evaluation modules and app reports at:

www.ti.com/sc/device/TPS65552A

The TPS65552A offers a complete solution for charging a photoflash capacitor from a battery input, and subsequently discharging the capacitor to the xenon tube. The device includes an integrated power switch, IGBT driver, and control logic blocks for charge applications.

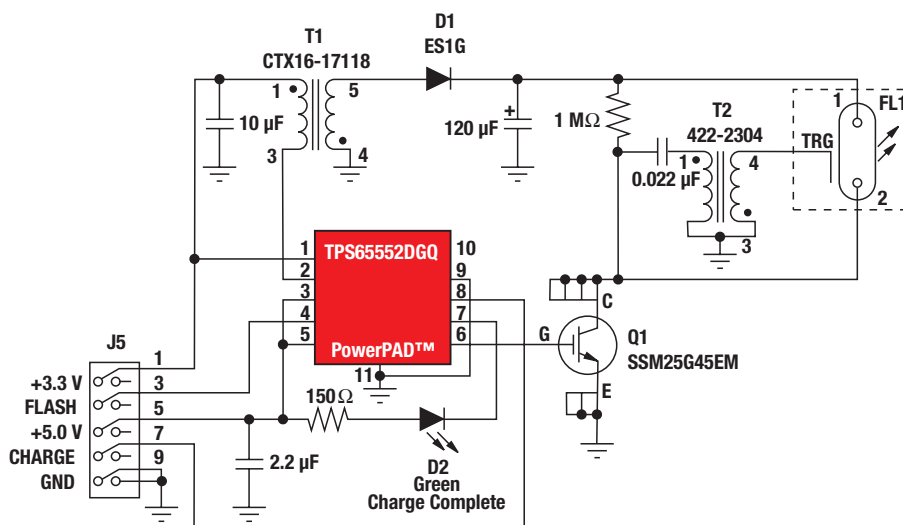

TPS65552A application circuit.

Selection Guide

Device ¹	Input Voltage (V)	V _{CC} (V)	Programmable Peak Current (A)	IGBT Driver	Maximum On Time	Overshoot Protection	Thermal Monitor	Package(s)	Price*
TPS65552A	1.8 to 12	5	0.95 to 1.8	✓	✓	✓	✓	10-pin MSOP, 16-pin QFN	1.25
TPS65560	1.6 to 12	3	0.9 to 1.8	✓	✓	✓	✓	16-pin QFN	0.85
TPS65561	1.6 to 12	3	1.1 to 2.2	✓	✓	✓	✓	16-pin QFN	0.95
TPS65562	1.6 to 12	3	0.9 to 1.8	✓	✓	✓	✓	16-pin QFN	0.95
TPS65563A	1.6 to 12	5.5	0.5 to 2	✓		(OCP only)	✓	16-pin QFN	0.70
TPS65573	1.6 to 12	5.5	0.5 to 1.5	✓		(OCP only)	✓	12-pin SON	0.55

¹All devices have a power-switch rating of 50 V.

*Suggested resale price in U.S. dollars in quantities of 1,000.

→ Charger Front-End Protection

Li+ Charger Front-End Protection IC

bq24314

Get samples, datasheets, evaluation modules and app reports at: www.ti.com/sc/device/bq24314

Charger front-end protection ICs provide protection from input overvoltage, input overcurrent and battery overvoltage conditions. The tri-level protection offers maximum safety when charging a handheld device. With integrated FET, the protection IC comes in 2x2-mm and 3x4-mm SON packages.

Features

- 30-V maximum input
- Up to 1.5-A input current
- Thermal shutdown
- Enable input

- Provides protection for three variables:
 - Input overvoltage (rapid response <1 μ s)
 - User-programmable overcurrent with current limiting
 - Battery overvoltage

Applications

- Mobile phones and smart phones
- Portable navigation devices
- MP3 Players
- Low-power handheld devices
- Bluetooth headsets

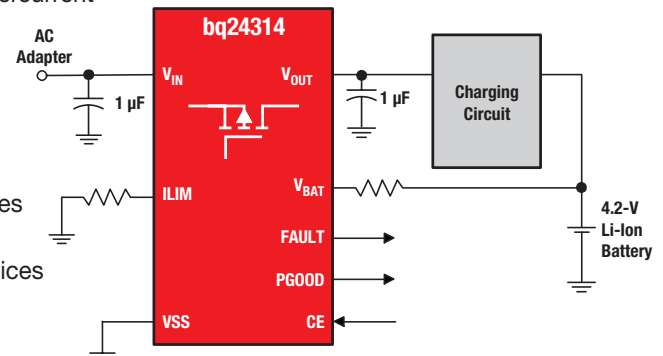

Selection Guide

Device	V _{IN} Max (V)	OVP (V)	OCP	Battery OVP (V)	LDO Output (V)	Max Operating Current (μ A)	Package(s)	EVM	Comments	Price*
bq24300/4/5	30	10.5	Fixed 300 mA	4.35	5.5/4.5/5.5	500	8-QFN/SON	✓	Reverse polarity protection	0.55
bq24305/8	30	6.3	Fixed 700 mA or Prog.	4.35	5	500	8-QFN/SON	✓	Reverse polarity protection	0.55
bq24314/A	30	5.85	Prog. <1.5 A	4.35	—	600	8/12-QFN/SON	✓	Fault indication	0.55/0.65
bq24315	30	5.85	Prog. <1.5 A	4.35	5.5	600	8-QFN/SON	✓	Fault indication	0.55
bq24316	30	6.5	Prog. <1.5 A	4.35	—	600	8/12-QFN/SON	✓	Fault indication	0.55
bq24380	30	6.3	No OCP	4.35	5.5	250	8-QFN/SON	✓	Fault indication	0.55
bq24381	30	7.1	No OCP	4.35	5	250	8-QFN/SON	✓	Fault indication	0.55
bq24382	30	10.5	No OCP	4.35	5	250	8-QFN/SON	✓	Fault indication	0.55
bq24350/2	30	6.17/7.1	Fixed 1.2 A	4.35	5.5	500	8-QFN/SON	✓	Integrated Charge FET	0.55

*Suggested resale price in U.S. dollars in quantities of 1,000.

→ Battery Charge Management

Design Factors

Battery Chemistry — Each battery chemistry has unique requirements for its charge algorithm, which is critical for maximizing its capacity, cycle life and safety.

Control Topology — A simple linear topology works well in applications with low-power (e.g., one- or two-cell Li-Ion) battery packs that are charged at less than 1 A. A switch-mode topology is ideally suited for fast charging from USB ports or for large battery packs that require charge rates >1 A. The switch-mode conversion minimizes heat generation during charging.

Input Voltage — Wide input-voltage range of the IC and input overvoltage protection offer maximum safety and allow use of low-cost unregulated wall adapters.

Li-Ion Charger with Automatic USB Detection

bq24050

Get samples, datasheets, evaluation modules and app reports at:

www.ti.com/sc/device/bq24050

The bq24050 can intelligently detect if a power source is a dedicated power adapter or a USB port. This feature allows a system to immediately start fast charging if a USB transceiver is not available because of a discharged battery.

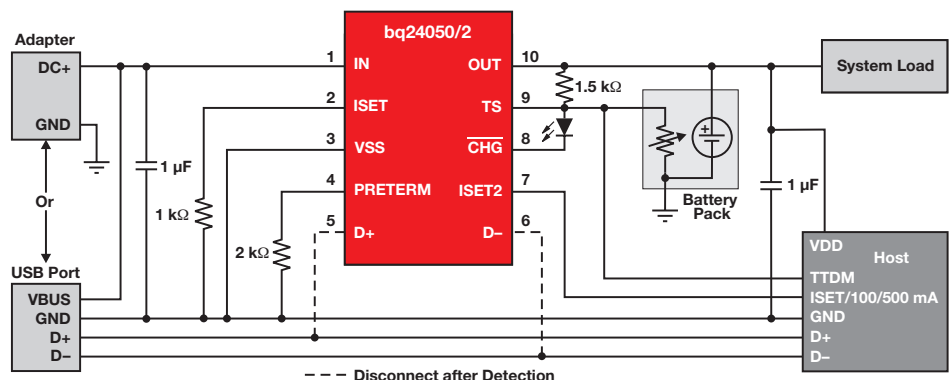



Selection Guide

Device	Number of Cells	Control Topology ¹	Integrated Power FET	Charge Current Internal FET	V _{IN} Max	Primary Charge Termination Method ²	Safety Timer	Temp Monitor	Packaging						EVM	Comments	Price*	
									WCSP	QFN/MLP	MSOP	TSSOP	SOIC	DIP				
Multi-Chemistry (Li-Ion and NiCd/NiMH)																		
bq2000/T	Multiple	Switching	No	—	7 V	PVD, $\Delta T/\Delta t$, min current	Yes	Yes				8	8	8	✓	Charges NiCd, NiMH, and Li-Ion	1.50	
bq24705	Multiple	Switching	No	—	30 V	Host controlled	No	No	24						✓	Small 4x4-mm package	1.85	
bq24721C	3 or 4	Switching	No	—	30 V	SMBus	No	Yes	32						✓	SMBus and system power selector	2.70	
bq24750A/51B	2, 3 or 4	Switching	No	—	30 V	Host controlled	No	Yes	28						✓	System power selector, Energy Star Low Iq	2.50	
bq24747	1 to 4	Switching	No	—	30 V	SMBus	Yes	No	28						✓	Level 2 charger with input current-detect comp.	2.90	
Li-Ion Chemistry																		
bq2057/C	1	Linear	No	—	18 V	Min current	No	Yes				8	8	8	✓	Low dropout, 4.1/4.2 V regulation, AutoComp™	0.90	
bq2057T/W	2	Linear	No	—	18 V	Min current	No	Yes				8	8	8	✓	Low dropout, 8.2/8.4 V regulation, AutoComp	0.80	
bq24010	1	Linear	Yes	1.0 A	18 V	Min current	Yes	No	10						✓	Allows use of unregulated wall supplies with high max V _{IN}	0.99	
		Parameter		bq24010		bq24012		bq24013		bq24014		bq24018						
		Optional Functions ³		PG, TS, 4.2 V		PG, CE, 4.2 V		CE, TTE, 4.2 V		CE, TS, 4.2 V		PG, TS, 4.36 V						
bq24020	1	Linear	Yes	1.0 A	7 V	Min current	Yes	Yes	10						✓	Autonomous USB and AC-adaptor supply management	0.99	
		Parameter		bq24020		bq24022		bq24023		bq24024		bq24025		bq24026		bq24027		
		Optional Functions ³		CE and TS		PG and CE		CE and TTE		TTE and TS		CE and TS		TE and TS		PG and CE		
		Fast Charge Timer/Taper Timer		5/Yes		5/Yes		5/Yes		5/Yes		7/No		7/No				
bq24030	1	Linear	Yes	1.5 A	18 V	Min current	Yes	Yes	20						✓	Dynamic Power-Path Management powers the system and charges battery	1.95	
		Parameter		bq24030†		bq24031†		bq24032A		bq24035		bq24038						
		Output for AC Input Condition		Regulated to 6 V		Regulated to 6 V		Regulated to 4.4 V		Cutoff at 6 V		Regulated to 4.4 V						
		Charge Regulation Voltage (V)		4.2		4.1		4.2		4.2		4.36						
bq24040	1	Linear	Yes	0.8 A	30 V	Min current	Yes	Yes	10						✓	USB compliant charger	1.15	
bq24050	1	Linear	Yes	0.8 A	30 V	Min current	Yes	Yes	10						✓	Automatic USB detection	1.45	
bq24060	1	Linear	Yes	1 A	18 V	Min current	Yes	Yes	10						✓	Thermal regulation, overvoltage protection, LDO mode	0.99	
		Parameter		bq24060		bq24061		bq24064										
		Optional Functions ³		TS		CE		TS										
		Input Overvoltage (V)		6.5		6.5		10.5										
bq24072	1	Linear	Yes	1.2 A	28 V	Min current	Yes	Yes	16						✓	Dynamic Power-Path Management, USB compliant	1.60	
		Parameter		bq24072		bq24073		bq24074		bq24075/T		bq24079/T						
		V _{BAT}		4.2 V		4.2 V		4.2 V		4.2 V		4.1 V						
		V _{QVP}		6.6 V		6.6 V		10.5 V		6.6 V		6.6 V						
		V _{OUT(REG)}		V _{BAT} + 225 mV		4.4 V		4.4 V		5.5 V		5.5 V						
		Pin #15		TD		TD		TERM		SYSOFF		SYSOFF						
bq24080	1	Linear	Yes	1.0 A	7 V	Min current	Yes	Yes	10						✓	Simple integrated charger	0.95	
		Parameter		bq24080		bq24081		bq24083										
		Optional Functions ³		PG and CE		TE and TS		PG and CE										
		Charge Regulation Voltage (V)		4.2		4.2		4.1										
bq24090	1	Linear	Yes	0.8 A	7 V	Min current	Yes	Yes	10						✓		0.88	
bq24100/8	1	Switching	Yes	2.0 A	20 V	Min current	Yes	Yes	20							bq24120 offers enhanced EMI performance	2.15	
bq24103/113	1 or 2	Switching	Yes	2.0 A	20 V	Min current/Host controlled	Yes	Yes	20							bq24123 offers enhanced EMI performance	2.40	
bq24105 [†] /115	1 to 3	Switching	Yes	2.0 A	20 V	Min current/Host controlled	Yes	Yes	20							bq24125 offers enhanced EMI performance	3.50	
bq25010/2/5/7	1	Linear	Yes	500 mA	7 V	Min current	Yes	No	20						✓	USB, integrated DC/DC converter	2.00	
bq2954	Multiple	Switching	No	—	—	Min current	Yes	Yes							✓	PWM control, low/high-side current sense	2.50	
NiCd/NiMH Chemistry																		
bq2002/C/E/F	Multiple	Current-limited	No	—	—	– ΔV , PVD, $\Delta T/\Delta t$	Yes	Yes				8	8		✓	Low-cost nickel charge ICs	1.00	
bq2004/E/H	Multiple	Switching	No	—	—	– ΔV , PVD, $\Delta T/\Delta t$	Yes	Yes				16	16		✓	Selectable timers and pulse-trickle rates	2.20	
bq2005	Multiple	Switching	No	—	—	– ΔV , $\Delta T/\Delta t$	Yes	Yes				20			✓	Sequential fast charge of two battery packs	2.20	
Lead-Acid Chemistry																		
bq24450	Multiple	Linear	No	—	40 V	Max V, min I	No	No				16	16		✓	Temp-compensated internal reference	2.75	
UC3909	Multiple	Switching	No	—	40 V	Max V, min I	No	Yes				20	20			Differential current sense input	3.05	
bq2031	Multiple	Switching	No	—	—	Max V, – $\Delta^2 V$, min I	Yes	Yes				16	16		✓	Three user-selectable charge algorithms to accommodate cyclic and standby applications	2.80	

¹Current-limited = gating control of external, current-regulated/limited source.

²PVD = peak voltage detection; $\Delta T/\Delta t$ = rate of temperature rise; host controlled = system processor must terminate charging;

– ΔV = negative voltage change; max V = maximum voltage; min I = minimum current; $\Delta^2 V$ = second difference of cell voltage.

³TS = temperature sensing; PG = power good; CE = charge enable; TTE = timer and termination enable.

[†]Devices qualified for Automotive applications are available with different pricing.

*Suggested resale price in U.S. dollars in quantities of 1,000.

Battery Fuel Gauges

Design Factors

Battery Chemistry — Each battery chemistry has different operating characteristics, such as discharge profiles and self-discharge rate. TI gas gauge ICs are developed by chemistry to account for these differences to accurately display remaining energy in the battery.

Features

TI gas gauges and battery monitors accurately track battery activity to compute the remaining battery capacity and system run-time. They feature:

- Simple communication protocols.
- High-resolution analog-to-digital converters for accurate charge/discharge measurement.
- Integrated CPU on gas gauges to compute remaining battery capacity and run-time.
- Advanced charge management satisfies JEITA specification of variable charging current and voltage with battery conditions.

99% Accurate Gas Gauge Maximizes Run-Time

bq20z40, bq20z45, bq20z60, bq20z65

Get samples, datasheets, evaluation modules and app reports at:

www.ti.com/sc/device/bq20z40

The dynamic Impedance Track™ gas gauge algorithm in the bq20z40 extends battery usability, allowing use of the full chemical capacity available in a battery pack. Additional features include instant state-of-charge and real-time impedance learning. Impedance Track also enables reduction in development and production time. Remaining capacity is reported over the entire life of the battery pack with better than 99% accuracy. The bq20z40 is ideally suited for battery packs used in medical and industrial equipment, back-up batteries and laptop computers.

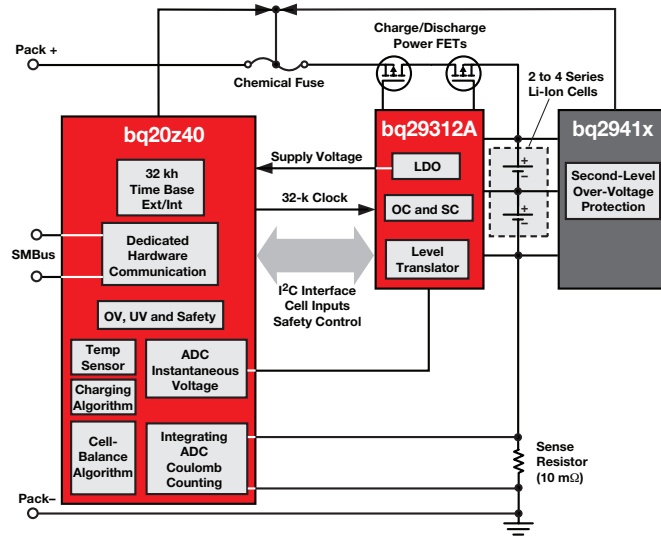

Typical gas-gauge application.

Battery Fuel Gauges Family of Products

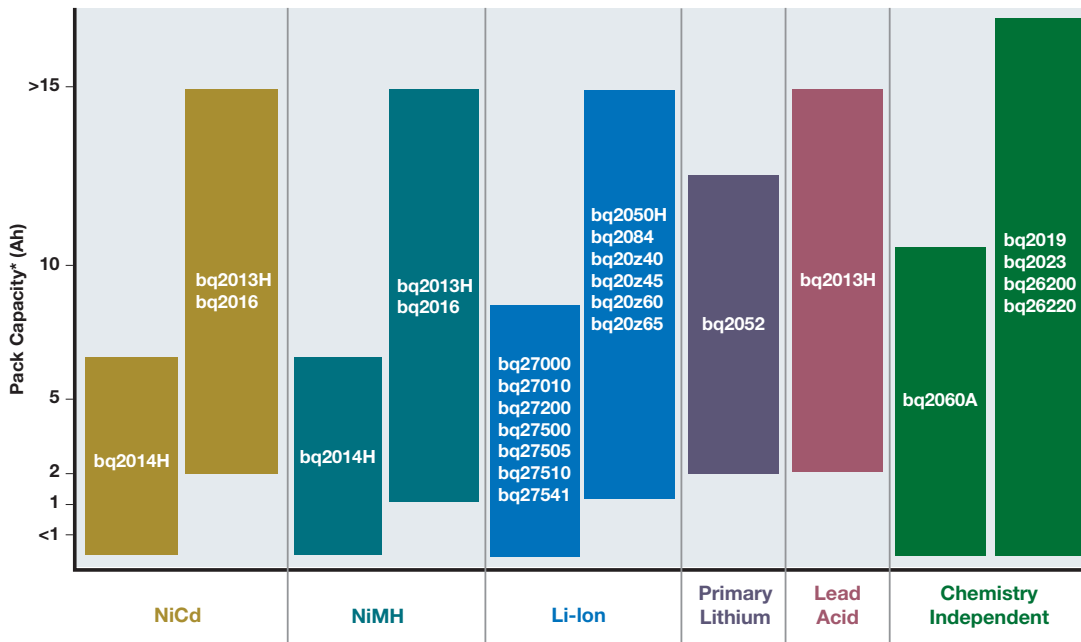

*Pack capacity ratings provide an approximate range for each gas gauge.



Selection Guide

Device	Approx. Battery Capacity (mAh)	Min Max Series Cell	Number of LEDs	Communication Protocol	Other Features	Safety Enhancement	Package	Price*
NiCd, NiMH Chemistry								
bq2013H	2000 to 15000	—	5	Single wire (HDQ)	Programmable offset error compensation	No	16-pin SOIC	3.70
bq2014H	500 to 6000	—	5	Single wire (HDQ)	Register compatible with bq2050H	No	16-pin SOIC	3.70
bq2016	1000 to 4500	—	5	Single wire (HDQ)	Automatic offset calibration	No	28-pin SSOP	3.00
Lithium-Ion, Lithium-Polymer Chemistry								
bq2050H	500 to 6000	—	5	Single wire (HDQ)	Register compatible with bq2014H	Yes	16-pin SOIC	3.70
bq2084	800 to 10000	2 to 4	3, 4 or 5	2 wire (SMBus)	SBS 1.1 works with bq29312 based on bq2083; includes bq2050 dataset via single wire interface	Yes	38-pin TSSOP	4.00
bq20z40R1	800 to 32000	2 to 4	No LED	SMBus	Impedance Track™ fuel gauge for use with bq29330 protector	Yes	20-pin TSSOP	3.40
bq20z45R1	800 to 32000	2 to 4	No LED	SMBus	Impedance Track fuel gauge with integrated protector	Yes	38-pin SMB	4.40
bq20z60R1	800 to 32000	2 to 4	3, 4 or 5	SMBus	Impedance Track fuel gauge for use with bq29330 protector	Yes	30-pin TSSOP	3.90
bq20z65R1	800 to 32000	2 to 4	3, 4 or 5	SMBus	Impedance Track fuel gauge with integrated protector	Yes	44-pin SMB	4.90
bq27000	300 to 6000	1	—	HDQ	Single-cell fuel gauge with fixed-voltage EOD	No	10-pin DRK	1.15
bq27200	300 to 6000	1	—	I ² C	Single-cell fuel gauge with fixed-voltage EOD	No	10-pin DRK	1.15
bq27010	300 to 6000	1	—	HDQ	Single-cell fuel gauge with compensated-voltage EOD	No	10-pin DRK	1.25
bq27210	300 to 6000	1	—	I ² C	Single-cell fuel gauge with compensated-voltage EOD	No	10-pin DRK	1.25
bq27500	300 to 6000	1	—	I ² C	Single-cell system-side fuel gauge w/ Impedance Track technology	No	12-pin QFN	1.35
bq27510	300 to 6000	1	—	I ² C	Single-cell system-side fuel gauge w/ Impedance Track technology with integrated LDO	No	12-pin QFN	1.45
bq27541	300 to 6000	1	—	I ² C	Single-cell battery-side fuel gauge w/ Impedance Track technology with authentication challenger	No	12-pin QFN	1.45
bq27501	300 TO 6000	1	—	I ² C	Single-cell system-side fuel gauge w/ Impedance Track technology with battery ID resistor	No	12-pin QFN	1.35
bq27505	300 TO 6000	1	—	I ² C	Single-cell system-side fuel gauge w/ Impedance Track technology	No	12-ball CSP	1.40
bq27550	300 to 6000	1	—	HDQ	Single-cell battery-side fuel gauge w/ Impedance Track technology with integrated protector, LDO and authentication challenger	No	12-pin QFN	1.55
bq27520	300 to 6000	1	—	I ² C	Single-cell system-side fuel gauge w/ Impedance Track technology with integrated LDO	No	15-ball CSP	1.50
bq78PL114	1000 to 650,000	3 to 12	—	SMBus	High-power gas gauge with protection and advanced cell balancing	—	48-pin QFN	4.50
bq76PL102	1000 to 650,000	1 to 2	—	PowerLAN	2-cell cell expansion to bq78PL114	—	12-pin QFN	1.50
Primary Lithium Chemistry								
bq2052	1000 to 12000	1	2, 4 or 5	Single wire (HDQ)	Automatic discharge compensation	No	16-pin SOIC	4.00
Lead Acid Chemistry								
bq2013H	2000 to 15000	10	5	Single wire (HDQ)	Programmable offset error compensation	No	16-pin SOIC	3.70
Multi-Chemistry								
bq2060A	800 to 10000	0.1	4 or 5	SMBus or HDQ16	SBS 1.1 extended cold temp cell modeling and high temp safety enhancement, improved bq2060	Yes	28-pin SSOP	3.90
Battery Monitors								
bq2019	>20000	1	—	Single wire (HDQ)	64-bit ID ROM and 1 program output non-volatile memory	—	8-pin TSSOP	1.95
bq2023	>20000	0.25	—	Single wire (SDQ)	64-bit ID ROM and 1 program output automatic offset error calibration	—	8-pin TSSOP	2.00
bq26200	>20000	0.25	—	Single wire (HDQ)	High-performance battery, coulomb counter	—	8-pin TSSOP	2.00
bq26220	>20000	0.25	—	Single wire (HDQ)	64-bit ID ROM and 1 program output on-chip voltage measurement	—	8-pin TSSOP	2.05

*Suggested resale price in U.S. dollars in quantities of 1,000.

New devices are listed in bold red.

For a complete list of Resources, visit: power.ti.com

→ Lithium-Ion Protection

Design Factors

Number of Series Cells — A battery is constructed from a string of series and parallel cells. Each series cell, or group of paralleled cells, requires protection from overcharge, overdischarge and short-circuit conditions.

Threshold Voltage — Li-Ion and Li-Polymer cells are produced by many manufacturers. Some manufacturers' technologies create cells of different maximum stress voltages, otherwise known as the "overvoltage threshold." This data is available from the cell supplier.

Threshold Tolerance — The overvoltage threshold has a tolerance that needs to be accounted for in the design for safety reasons.

Shutdown Current — In battery pack applications, constant current draw needs to be very low to preserve battery life.

Charge/Discharge Current — The pass element associated with each protection IC is rated for maximum current whether it be an internal or external FET.

Lithium-Ion Protection Family of Products

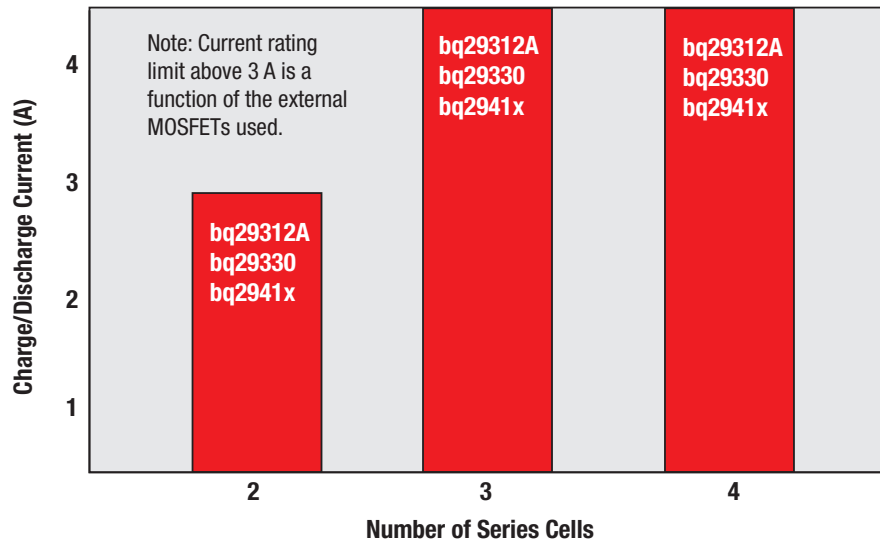

Features

- BiCMOS process results in low current consumption.
- Different overvoltage thresholds allow one design to work with several cell suppliers.
- Sleep current consumption of less than 3.5 μA enables extended battery life.
- 50 mV precision internally trimmed thresholds maximize safety.
- Short-circuit protection eliminates the need for an external fuse.

Selection Guide

Device	Number of Series Cells	Charge/Discharge Current (A)	Threshold Voltage (V_{OV})	Shutdown Current (μA)	Other Features	Package	Price*
bq29312A	2, 3 or 4	External FET	bq2084 ¹ , bq20z80 ¹	1	Integrated LDO, works directly with bq2084 and bq20z80 gas gauge	24-pin TSSOP	1.00
bq29330	2, 3 or 4	External FET	bq20z90 ¹	1	Integrated LDO, works directly with bq20z90 gas gauge	20-pin TSSOP	1.00
bq2941x	2, 3 or 4	—	x = voltage level	1	Second overvoltage safety for chemical fuse activation	8-pin TSSOP	0.45
bq77PL900	5 to 10	External FET	Voltage and Current	—	Standalone or host controlled protector with cell balancing	48-pin SSOP	2.95

¹ Controlled by bq208x, bq20z8x or bq20z9x gas gauge.

See individual datasheets for full details.

*Suggested resale price in U.S. dollars in quantities of 1,000.

New devices are listed in bold red.

For a complete list of Resources, visit: power.ti.com

Authentication for Batteries and Peripherals



Design Factors

Original equipment manufacturers specify products to achieve required performance and safety goals. Authentication ensures that connected devices fulfill the established requirements and are safe for the consumer.

Features

TI authentication devices use three levels of security.

- **Identification Number** — The host controller can request an identification number that is answered with a fixed response.
- **CRC Algorithm** — The host processor sends a random challenge and reads the response that is an encoding of the challenge and a shared secret key through a CRC with a shared secret polynomial.
- **SHA-1 Encryption** — The host processor sends a random challenge and reads the response that is an encoding of the challenge and a shared secret key through the SHA-1 cryptographic primitive.

Single-Cell Battery Pack with Gas Gauge and Authentication

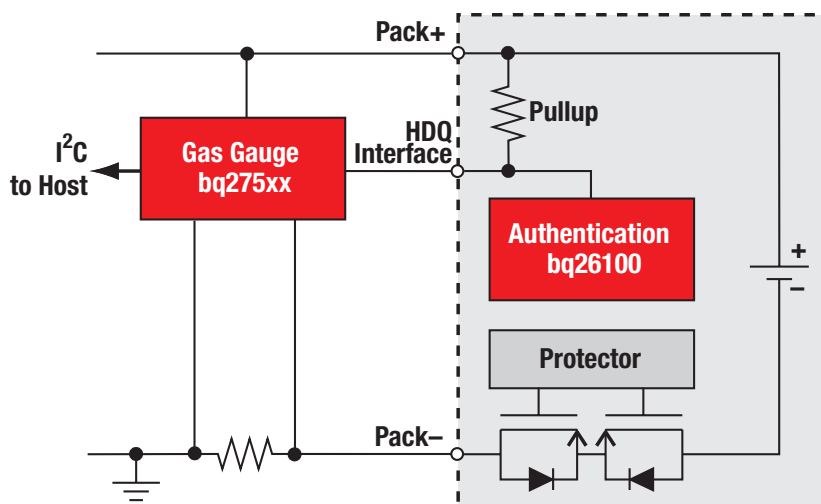

Selection Guide

Device	Interface	Pins	Security	Temp (°C)	Price*
bq2022A	SDQ	3	ID number	-40 to 85	1.25
bq2024	SDQ	3	ID number	-40 to 85	1.25
bq26150	HDQ	5	CRC algorithm	-20 to 70	1.25
bq26100	SDQ	5	SHA-1 encryption	-20 to 70	1.30

*Suggested resale price in U.S. dollars in quantities of 1,000.

Hot Swap and Power Distribution



Design Factors

The concept of providing power along with data is as old as plain old telephone service, but the formal standard for providing power along Ethernet lines is much more recent. Though the original Power-over-Ethernet (PoE) specification was approved in 2005, the IEEE ratified a superseding standard in summer 2009—the IEEE 802.3at. Both standards specify behavior for devices receiving power across Ethernet lines, known as “powered devices” (PDs), and methods for injecting power onto the line, used in equipment known as “power sourcing equipment” (PSE).

Powered Devices (PDs)—A powered device typically has a front-end IC to pull power off of the Ethernet line and safely pass it through to the rest of the system. It is important that these PD front ends be robust enough to withstand 100-V surges while ensuring that the current is ramped in a controlled fashion into the PD. Most PD front ends, like the TPS23753A, incorporate a DC/DC converter to downconvert the PoE voltage to a suitable voltage. The 802.3at Type I PDs (adherents of the original 802.3af standard, with some updates) are guaranteed at 12.95 W, while 802.3at applications are allowed up to 25.5 W of power.

Power-over-Ethernet

Power Sourcing Equipment (PSE)—PSE is typically found in either Ethernet switches (“endspan”) or a device between the Ethernet switch and the PD (“midspan”). In both cases, power is injected onto the line for a PD to use. PSE is responsible for querying the PDs and legacy clients to ensure that they want power to be applied and that they do not pull more power than allowed. All PSE performs some level of hardware authentication for initial power application to PDs, while newer 802.3at PSEs can query with either an additional hardware layer or a software layer of communication to provide more than 12.95 W of power to the PD.



Power-over-Ethernet

New PoE Products for a New Standard!

High-Power/High-Efficiency PoE Interface and DC/DC Controller

TPS23754/6

The TPS23754/6 incorporates a high-power PD front end along with a DC/DC converter capable of highly efficient, isolated downconversion topologies. With full 802.3at compliance and an additional gate driver for secondary-side active clamp rectification, the

TPS23754/6 is an easy choice for high-power PoE applications.

Key Features

- 802.3at-hardware compliant
- Secondary gate driver for active clamp rectification

- Support for auxiliary power-supply selection using APD pin
- 100-V monolithic process for robust operation

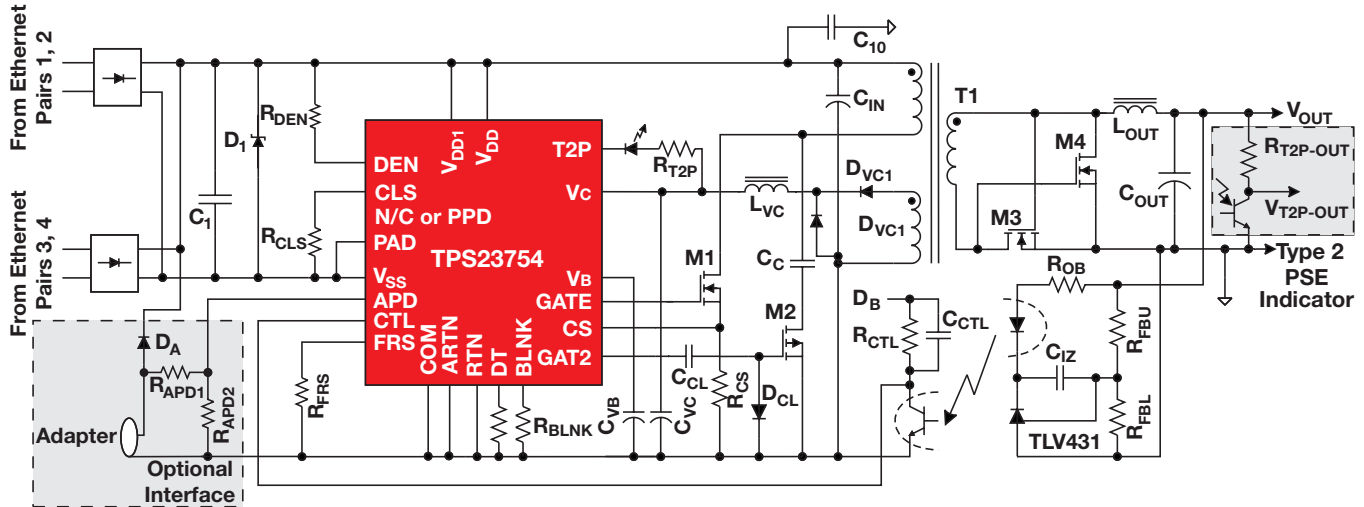

Original PoE . . . Only Better!

The vast majority of PoE applications need less than 12.95 W. For this growing market area, TI has a large portfolio of options to consider:

TPS23753A

- Simplest, most elegant, lowest-cost solution for a standard PoE PD
- Incorporates rugged tolerance for extended ESD exposure
- Auxiliary power supplies are fully supported—down to 12 V!

TPS23757

- Secondary gate driver enables high-efficiency, isolated topologies for applications requiring 12.95 W or less
- Pin-for-pin compatible with the TPS23756, providing an easy path for low- or high-power applications
- Operates with auxiliary input power supplies as low as 12 V

TPS23750

- TI's original PD front end plus DC/DC converter
- Supports simple, low-cost, non-isolated buck-converter topologies with no transformer required

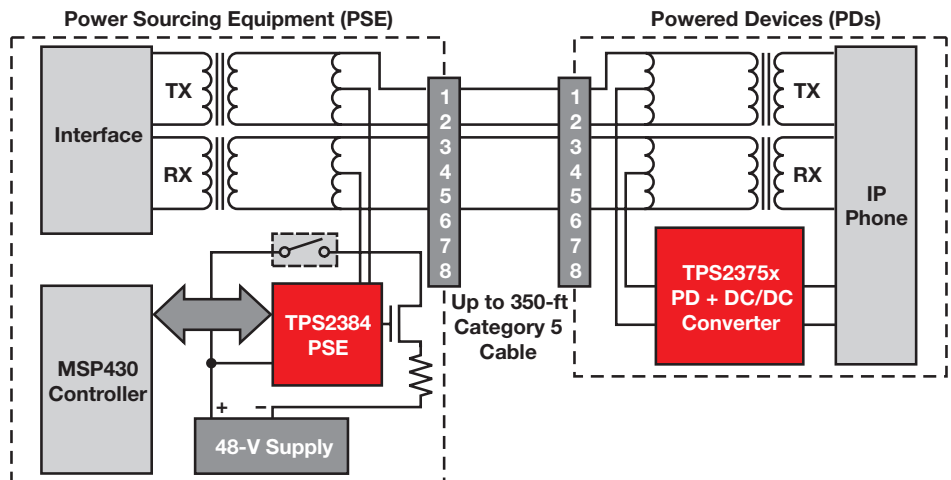

The new TPS2384 and TPS2375x are IEEE 802.3af-compliant power-management ICs designed for managing the connection between Power Sourcing Equipment (PSE) and Powered Devices (PDs) over Ethernet cables (see: www.ti.com/poe). The TPS2384 is a quad-port PSE power manager with onboard FETs and individual ADCs per port for maximum monitoring and control.



Selection Guide

Device	Description	Abs Max V _{IN} (V)	Operating Temp (°C)	Full Inrush Current Limiting	Current Limit (mA)	Second Gate Driver for Maximum Efficiency?	Package(s)	Price*
Power-over-Ethernet (PoE) Powered Device (PD) Controllers with Integrated DC/DC Controllers								
TPS23750	Integrated PD with PWM controller	100	-40 to 85	Fixed	405	No	TSSOP-20	1.50
TPS23753A	PD+controller with AUX ORing	100	-40 to 85	Fixed	405	No	TSSOP-14	1.45
TPS23754	High-power PD + high-efficiency controller	100	-40 to 125	Fixed	850	Yes	TSSOP-20 PowerPAD	1.90
TPS23756	High-power PD + high-efficiency controller (12-V startup)	100	-40 to 125	Fixed	850	Yes	TSSOP-20 PowerPAD	1.90
TPS23757	PD + high-efficiency controller	100	-40 to 125	Fixed	405	Yes	TSSOP-20	1.65
TPS23770	Integrated PD with PWM controller	100	-40 to 85	Fixed	405	No	TSSOP-20	1.50
PTB48540	5-V, 10-W PoE power module	100	-40 to 85	Fixed	405	N/A	13-DIP Module	18.00

Device	Description	Detection	Classification	Abs Max V _{IN} (V)	Operating Temp (°C)	Full Inrush Current Limiting	Current Limit (mA)	Auto Retry or Latch Off in Fault	UVLO	DC/DC Interface	Package(s)	Price*
Power-over-Ethernet (PoE) Powered Device (PD) Interface Front-End Controllers												
TPS2375	Powered device controller	4	Yes, Class 0-4	100	-40 to 85	Programmable	450	Latch Off	802.3af (30.6/39.4 V)	PG	SOIC-8, TSSOP-8	1.25
TPS2375-1	Powered device controller	4	Yes, Class 0-4	100	-40 to 85	Programmable	450	Auto Retry	802.3af (30.6/39.4 V)	PG	TSSOP-8	1.00
TPS2376	Powered device controller	4	Yes, Class 0-4	100	-40 to 85	Programmable	450	Latch Off	Adjustable	PG	SOIC-8, TSSOP-8	1.25
TPS2376-H	High-power powered device cont.	4	Yes, Class 0-4	100	-40 to 85	Programmable	600	Auto Retry	Adjustable	PG	SOIC-8	1.25
TPS2377	Powered device controller	4	Yes, Class 0-4	100	-40 to 85	Programmable	450	Latch Off	Legacy (30.5/35.0 V)	PG	SOIC-8, TSSOP-8	1.25
TPS2377-1	Powered device controller	4	Yes, Class 0-4	100	-40 to 85	Programmable	450	Auto Retry	Legacy (30.5/35.0 V)	PG	SOIC-8	1.00

Device	Applications	Channels	Abs Max V _{IN} (V)	Operating Temp (°C)	IEEE Compliant	Interface	Disconnect	Measurements	Power FET	Package	Price*
Power-over-Ethernet (PoE) Power Sourcing Equipment (PSE) Controllers											
TPS2384	Routers, switches, SOHO hubs, midspans	4	80	-40 to 125	Yes	I ² C	Both AC and DC	Current, voltage, capacitance and temperature	Internal	64-pin LQFP	5.10
TPS23841	Proprietary, higher-power 24-V/48-V PoE switches, hubs, midspans	4	80	-40 to 125	Yes	I ² C	Both AC and DC	Current, voltage, capacitance and temperature	Internal	64-pin LQFP	8.05

*Suggested resale price in U.S. dollars in quantities of 1,000.

For additional resources on PoE, including reference designs and evaluation modules, please see:

www.ti.com/poe

Hot Swap Power Management

Protection Circuitry

Protecting designs from unwanted inrush current, reverse current flow, or malfunction is challenging. The following questions and answers cover typical application design issues.

Can the board ever pull too much current?

If the design involves devices that plug into live systems (hot swaps), the answer is probably “yes.” If the design has subsystems that need to be turned on and off via a pass FET or some other device, unwanted inrush current could be a problem when those systems are activated. In these cases, choosing a current-limiting switch or a hot-swap manager will control this input. Here are

some key considerations that will make product selection easier:

1. *What is the voltage? How much nominal current does the system draw?* If the system has low voltage (< 20 V) and draws less than 5 A continuously, a hot-swap controller such as the TPS2420/1 with an internal FET and sense element is a likely choice. For higher voltages and/or higher currents, an external FET and a hot-swap controller IC such as the TPS2490/1 is a good solution.
2. *Are defined periods of time needed during which additional current can flow to the load (for example, during start-up)?* If so, a constant-current switch or a configurable timer on a hot-swap controller is important.

Good examples of these are the TPS2552/3 devices, which are simple switches with only thermal shutdown, and the TPS2420, which has a configurable timer.

3. *Does the amount of current flowing to the load need to be monitored?* The TPS2420 and TPS2x58/9 have analog current-monitoring pins that are ideal for use with sequencers such as the UCD9081 on page 69 or with any microcontroller with an onboard ADC such as TI’s MSP430. The TPS2480/1 external FET devices have directly addressable digital outputs of current readings via I²C.

Is the power supply at risk from reverse current flow?

If the system has a battery backup, supercapacitor, or alternate power supply, the

Low-Voltage Protection-Circuitry Products

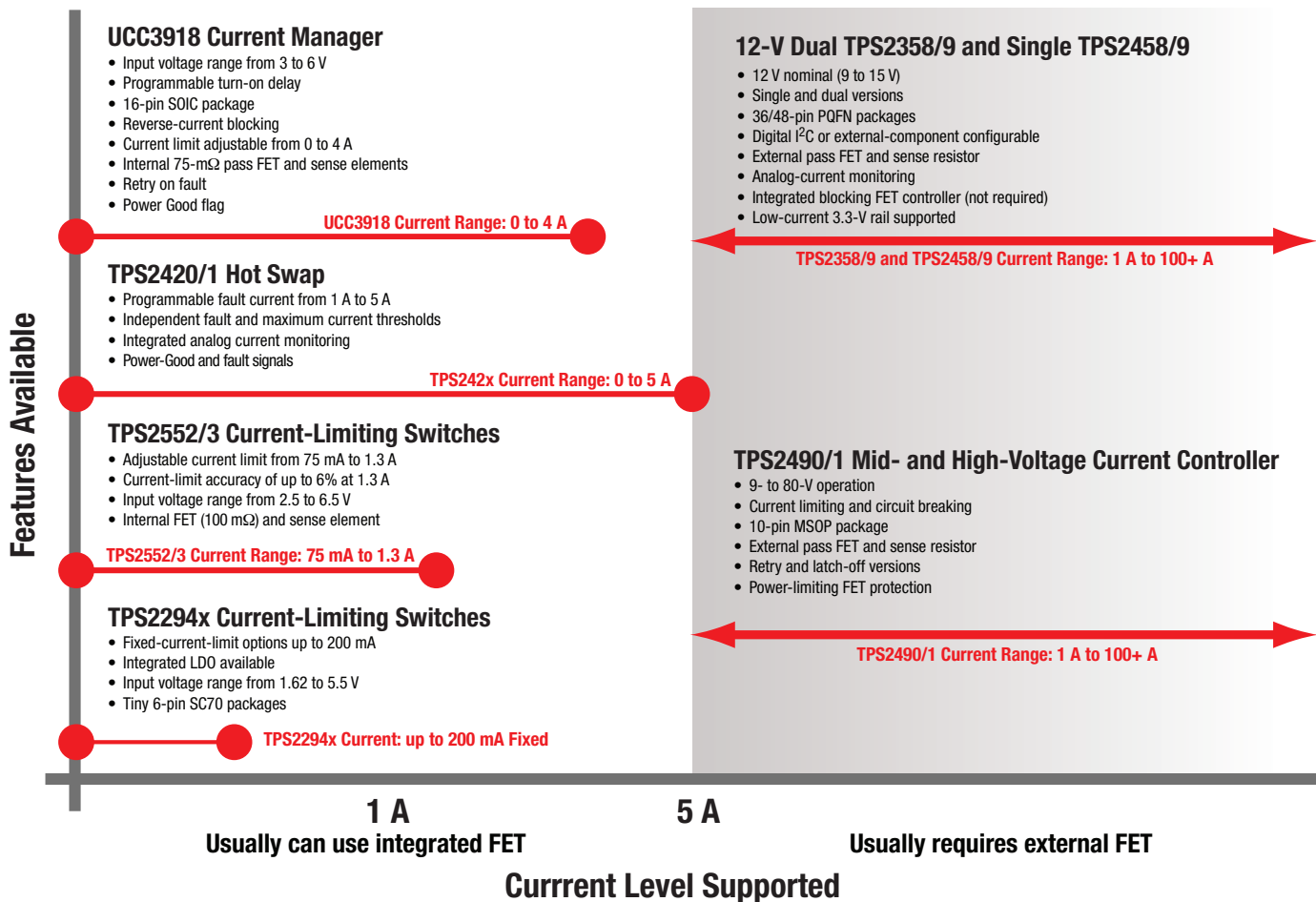

Hot Swap Power Management



answer is probably “yes.” Also, if it is important to control which source is powering the board, ORing FET controllers such as the TPS2410 or combination devices could be very useful. Here are some key questions to consider:

1. *What is the voltage? How much nominal current does the system draw?*
For systems from 0.8 V to 16.5 V, the TPS2410/1/2/3 are great options

that control external FETs, providing flexibility for the amount of current passing through to the load. Features like soft start, nuisance trip filters, and external control via UV/OV pins are key aspects for many designs.

2. *Are the system's currents and voltages low enough to use a single device?* Many lower-voltage (2.7- to 6.5-V) solutions that consume less

than 1.5 A per rail could make use of integrated MUX devices such as those on page 64.

If protection from both reverse current and inrush current is needed, check out the TPS2458/9 devices, which incorporate both an ORing FET controller and a hot-swap controller.

Integrated 12-V Hot Swap Controller and ORing FET Controller

TPS2459

Get samples, datasheets, evaluation modules and app reports at: www.ti.com/sc/device/TPS2459

Features

- Hot-swap control on 12-V, 3.3-V rails
- I²C programmability for easy flexible configuration and monitoring
- ORing for 3.3 V and 12 V (Optional, not shown)
- Twice the overcurrent threshold accuracy
- Minimal external components

Applications

- Telecom connectivity
- Processors
- Network communication processors (NPU)
- Mass storage
- Ideal for systems requiring scalability and redundancy

Enabling technology for any 12-V based system, such as telecom carrier boards, μ TCA power modules and AdvancedMC™ slots.

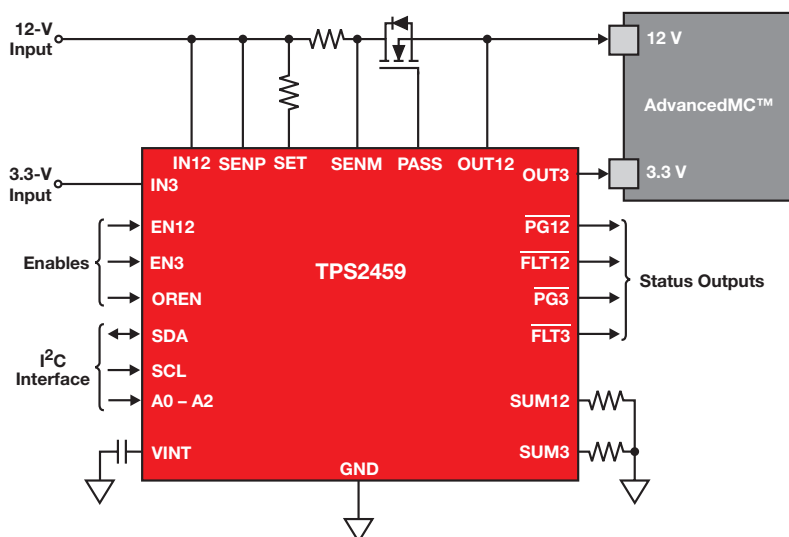



Hot Swap Power Management

Hot Swap Switches (Integrated FET) Selection Guide

Device	Target Applications	Channels	V _{IN} (V)	Current Limit (A)	r _{DS(on)} per FET (typ) (mΩ)	Enable/Shutdown	Ramp	Package(s)	Price*
TPS2420	Hot swap with current monitor & pwr limiting	1	3 to 20	1 to 5	20	1L	Current	16 pin SON	1.95
TPS2421-1	Hot swap with pwr limiting, latch-off on fault	1	3 to 20	1 to 5	20	1L	Current	SOIC-8	1.60
TPS2421-2	Hot swap with pwr limiting, retry on fault	1	3 to 20	1 to 5	20	1L	Current	SOIC-8	1.60
TPS2552	Current-limiting switch, constant-current	1	2.5 to 6.5	0.75 to 1.3	85	1L	Current	6 pin SOT-23, SON	0.70
TPS2552-1	Current-limiting switch, latch-off on fault	1	2.5 to 6.5	0.75 to 1.3	85	1L	Current	6 pin SOT-23, SON	0.70
TPS2553	Current-limiting switch, constant-current	1	2.5 to 6.5	0.75 to 1.3	85	1H	Current	6 pin SOT-23, SON	0.70
TPS2553-1	Current-limiting switch, latch-off on fault	1	2.5 to 6.5	0.75 to 1.3	85	1H	Current	6 pin SOT-23, SON	0.70
TPS2590	Current-limiting switch, configurable fault	1	3 to 20	1 to 5	20	1L	Current	16 pin SON	1.10
UCC3915	Enclosure management, general	1	7 to 15	0 to 3	150	1L	Current	SOIC-16, TSSOP-24	2.55
UCC3912	RAID, SCSI, general	1	3 to 8	0 to 3	150	1L	Current	SOIC-16, TSSOP-24	2.30
UCC3918	RAID, SCSI, general	1	3 to 6	0 to 4	75	1L	Current	SOIC-16, TSSOP-24	2.35

*Suggested resale price in U.S. dollars in quantities of 1,000.

Hot Swap Controllers (External FET) Selection Guide

Device	Target Applications	Channels	V _{IN} Range (V)	Enable/Shutdown	UV	OV	Fault	PG	Latch	Auto Retry	Ramp	Power Limiting	Package(s)	Price*
TPS2300/01	CompactPCI, general	2	3 to 13/3 to 5.5	1L/1H	✓		✓	✓	✓		Voltage	No	20-pin TSSOP	1.60
TPS2310/11	CompactPCI, general	2	3 to 13/3 to 5.5	1L/1H	✓		✓	✓	✓		Voltage	No	20-pin TSSOP	1.60
TPS2320/21	CompactPCI, general	2	3 to 13/3 to 5.5	1L/1H	✓		✓	✓	✓		Voltage	No	16-pin SOIC/TSSOP	1.35
TPS2330/31	CompactPCI, general	1	3 to 13	1L/1H	✓		✓	✓	✓		Voltage	No	14-pin SOIC/TSSOP	1.25
UCC3919	Low-voltage general hot swap	1	3 to 8	1H			✓		S ¹	S ¹	Current	No	16-pin SOIC/TSSOP	2.35
TPS2342	CompactPCI, PCI-X, PC-X2.0	12	3.3, V _{aux} , V _{IO} , 5, +12, -12	1L	✓			✓	✓		Voltage	No	80-pin HTQFP	7.00
TPS2343	CompactPCI, PCI-X, PC-X2.0	12	3.3, V _{aux} , V _{IO} , 5, +12, -12	1L	✓			✓	✓		Voltage	No	80-pin HTVSO	7.50
TPS2350	Full featured -48-V telecom, LS active ORing	2	-12 to -80	1H	✓	✓	✓	✓	✓	✓	Current	No	14-pin SOIC/TSSOP	1.90
TPS2358	xTCA Mezzanine cards, general 12 V	2	8.5 to 17	2L	✓		✓	✓	✓		Current	No	48-pin QFN	4.00
TPS2359	xTCA Mezzanine cards, general 12 V	2	8.5 to 17	1H/1L	✓	✓	✓	✓	S ¹	S ¹	Current	No	36-pin QFN	5.00
TPS2363	PCI Express	6	3.3 V _{aux} , 3.3, +12	1L	✓		✓	✓	✓		Voltage	No	48-pin QFP	2.50
TPS2390	Simple -48-V telecom	1	-36 to -80	1H			✓		✓		Current	No	8-pin MSOP	1.00
TPS2391	Simple -48-V telecom	1	-36 to -80	1H			✓			✓	Current	No	8-pin MSOP	1.00
TPS2392	Full featured -48-V telecom	1	-20 to -80	1H	✓	✓	✓	✓	✓		Current	No	14-pin TSSOP	1.80
TPS2393	Full featured -48-V telecom	1	-20 to -80	1H	✓	✓	✓	✓		✓	Current	No	14/44-pin TSSOP	1.80
TPS2393A	Full featured -48-V telecom (Fast retry)	1	-20 to -80	1H	✓	✓	✓	✓		✓	Current	No	14-pin TSSOP	1.80
TPS2398	Simple -48-V telecom with PG	1	-36 to -80	1H				✓	✓		Current	No	8-pin MSOP	1.25
TPS2399	Simple -48-V telecom with PG	1	-36 to -80	1H				✓		✓	Current	No	8-pin MSOP	1.25
TPS2400	Overvoltage/undervoltage protection IC	1	2 to 100	1H	✓	✓			✓		—	No	SOT-23-5	0.80
TPS2410/1	N+1 and OR-ing power rail controller	1	0.8 to 18	1H	✓	✓	✓	✓	✓		Voltage	No	14-pin TSSOP	1.70
TPS2412/3	N+1 and OR-ing power rail controller	1	0.8 to 18	1H					✓		Voltage	No	14-pin TSSOP	1.20
TPS2458	xTCA Mezzanine cards, general 12 V	1	8.5 to 17	1L	✓		✓	✓	✓		Current	No	32-pin QFN	2.00
TPS2459	xTCA Mezzanine cards, general 12 V	1	8.5 to 17	1H/1L	✓	✓	✓	✓	S ¹	S ¹	Current	No	32-pin QFN	2.50
TPS2480	Servers, basestations, +48 V, +12 V	1	9 to 80	1H	✓			✓	✓		Current	Yes	20-pin TSSOP	3.00
TPS2481	Servers, basestations, +48 V, +12 V	1	9 to 80	1H	✓			✓		✓	Current	Yes	20-pin TSSOP	3.00
TPS2490	Servers, basestations, +48 V, +12 V	1	9 to 80	1H	✓			✓	✓		Current	Yes	10-pin MSOP	1.70
TPS2491	Servers, basestations, +48 V, +12 V	1	9 to 80	1H	✓			✓		✓	Current	Yes	10-pin MSOP	1.70

¹S = Selectable.

*Suggested resale price in U.S. dollars in quantities of 1,000.



The Integration/Size Advantage

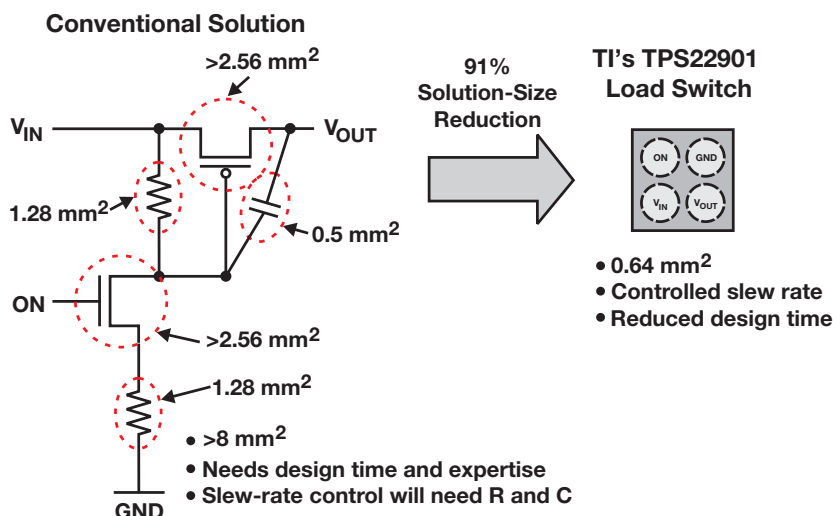

Portable Electronics Integrated Load Switches Product Portfolio

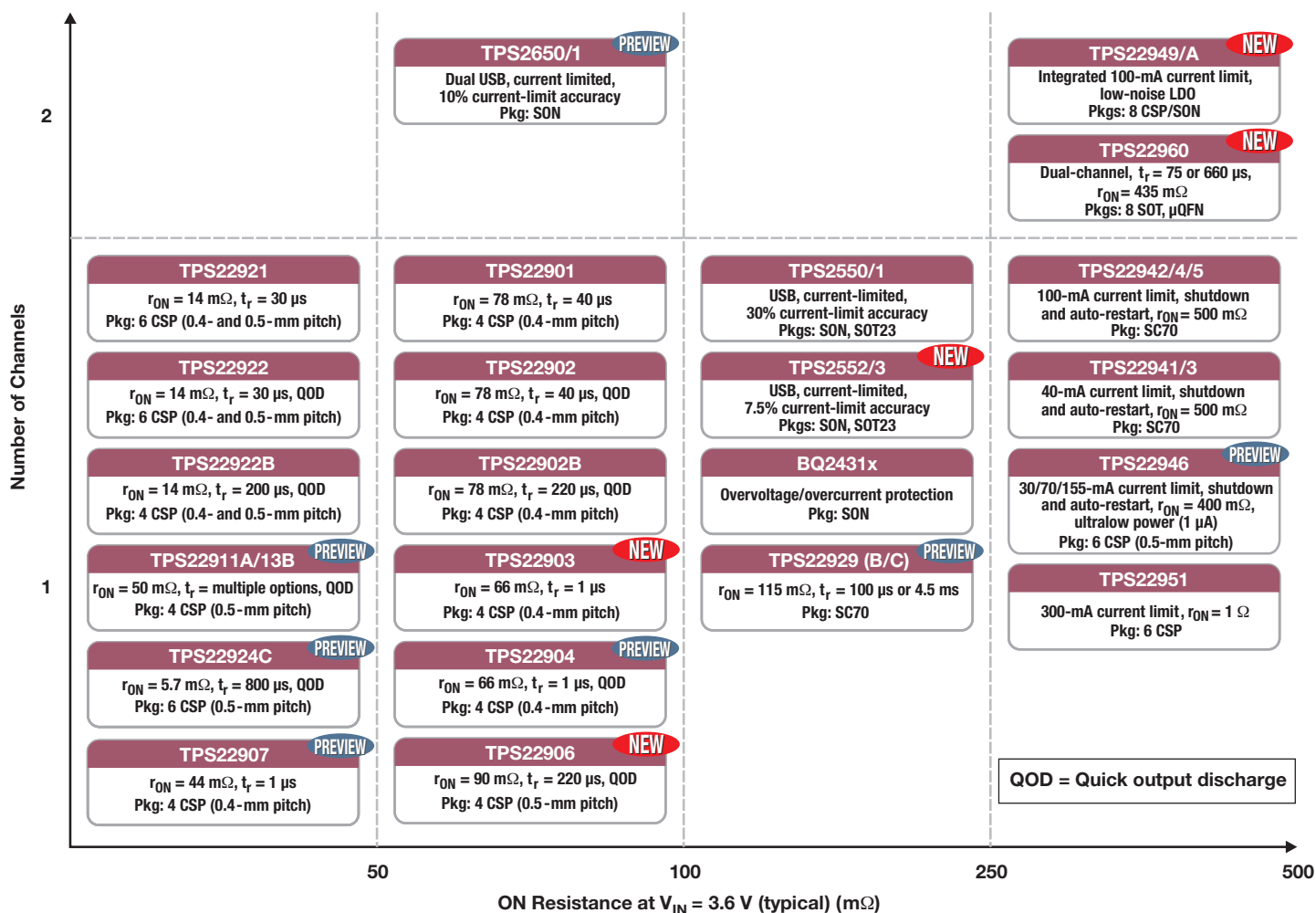

→ Load Switches

DLS Non-Current-Limited Load Switches Product Portfolio

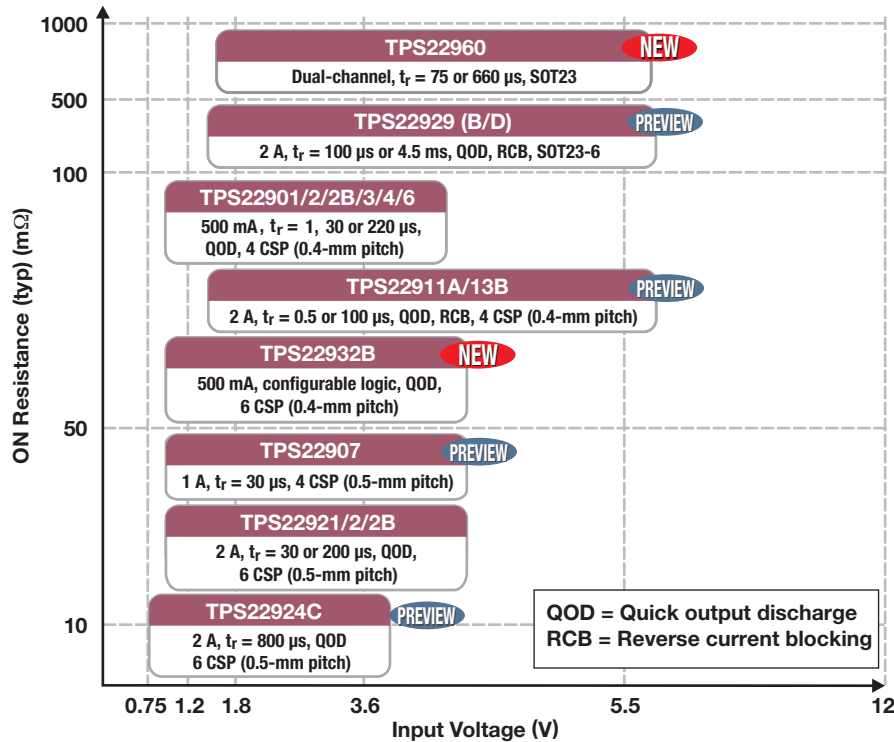

Selection Guide

Device	Input Voltage Range (V)	Number of Channels	r_{ON} at 3.6 V (mΩ)	Output Rise Time (μs)	Quick Output Discharge	Max Output Current	Enable	Package(s)	Price*
Non-Current-Limiting Load Switches									
TPS22901	1.0 to 3.6	1	78	40	No	500 mA	Active high	CSP (0.8x0.8 mm)	0.32
TPS22902	1.0 to 3.6	1	78	40	Yes	500 mA	Active high	CSP (0.8x0.8 mm)	0.32
TPS22902B	1.0 to 3.6	1	78	220	Yes	500 mA	Active high	CSP (0.8x0.8 mm)	0.32
TPS22903	1.1 to 3.6	1	66	1	No	500 mA	Active high	CSP (0.8x0.8 mm)	0.32
TPS22906	1.0 to 3.6	1	90	220	Yes	500 mA	Active high	CSP (0.9x0.9 mm)	0.32
TPS22907	1.1 to 3.6	1	44	36	No	1 A	Active high	CSP (0.9x0.9 mm)	0.38
TPS22913B	1.4 to 5.5	1	50	100	Yes	2 A	Active high	CSP (0.9x0.9 mm)	TBD
TPS22921	0.9 to 3.6	1	14	30	No	2 A	Active high	CSP (0.8x1.2 mm or 0.9x1.4 mm)	0.43
TPS22922	0.9 to 3.6	1	14	30	Yes	2 A	Active high	CSP (0.8x1.2 mm or 0.9x1.4 mm)	0.43
TPS22922B	0.9 to 3.6	1	14	200	Yes	2 A	Active high	CSP (0.8x1.2 mm or 0.9x1.4 mm)	0.43
TPS22924C	0.75 to 3.6	1	6	800	Yes	2 A	Active high	CSP (0.9x1.4 mm)	0.55
TPS22929B	1.4 to 5.5	1	110	100	Yes	2 A	Active high	SOT23-6 (3x3 mm)	TBD
TPS22929D	1.4 to 5.5	1	110	4500	Yes	2 A	Active high	SOT23-6 (3x3 mm)	TPD
TPS22932B	1.1 to 3.6	1	55	165	Yes	500 mA	Configurable	CSP (0.8x1.2 mm)	0.55
TPS22960	1.62 to 5.5	2	435	75 or 660	Yes	500 mA	Active high	SOT23-8 (3x3 mm), μ QFN (1.5x1.5 mm)	0.42

Device	Input Voltage Range (V)	r_{ON} at 1.8 V (Ω)	Current Limit (mA)	Current-Limit Blanking Time (ms)	Auto-Restart Time (ms)	Active	Package(s)	Price*
Current-Limiting Load Switches								
TPS22941	1.62 to 5.5	1.1	40	10	80	Low	5 SC70	0.42
TPS22942	1.62 to 5.5	1.1	100	10	80	Low	5 SC70	0.42
TPS22943	1.62 to 5.5	1.1	40	0	—	High	5 SC70	0.42
TPS22944	1.62 to 5.5	1.1	100	0	—	High	5 SC70	0.42
TPS22945	1.62 to 5.5	1.1	100	10	80	High	5 SC70	0.42
TPS22946	1.62 to 5.5	0.6	155/70/30	10	70	High	6 CSP	0.55
TPS22949	1.62 to 4.5	1	100	12	70	High	8 CSP	0.70
TPS22949A	1.62 to 4.5	1	100	12	70	High	8 CSP/SON	0.70
TPS22951	2.8 to 5.3	1	600	—	—	High	6 CSP	0.45

*Suggested resale price in U.S. dollars in quantities of 1,000.

Preview devices are listed in **bold blue**.



Design Factors

USB High-Power Peripheral Switch With Dual Current Limit + LDO

TPS2140/41/50/51 — The TPS2140/41/50/51 target high-power USB peripherals such as ADSL modems. The devices contain a power switch and an LDO. The dual-current-limiting switch allows the use of high-value capacitance to stabilize the voltage from the USB bus.

Dual Power Switch + LDO for USB Bus-Powered Peripherals and Hubs

TPS2148/49 — TPS2148 is a complete power management solution for USB bus-powered peripherals such as zip drives, while TPS2149 is for USB bus-powered hubs, such as keyboards with integrated hubs. TPS2148/9 each combine a 3.3-V LDO and dual power switch in a single MSOP. The TPS2148 switch configuration allows power and board capacitance segmentation to meet USB system current requirements. The TPS2149 switches manage two independent or four ganged USB ports.

4-Port USB Hub Power Controllers

TPS207x — The TPS207x family provides the complete power solution for 4-port self-powered, bus-powered

USB Devices Family of Products

4-Port USB Hub Power Controllers

Device	5-V LDO Controller	Bus Power Mode Indicator	Pins	Package
TPS2070	Yes	Active Low	32	HTSSOP
TPS2071	Yes	Active High	32	HTSSOP
TPS2074	No	Active Low	24	SSOP
TPS2075	No	Active High	24	SSOP

Dual Power Switch + LDO for USB Bus-Powered Peripherals and Hubs

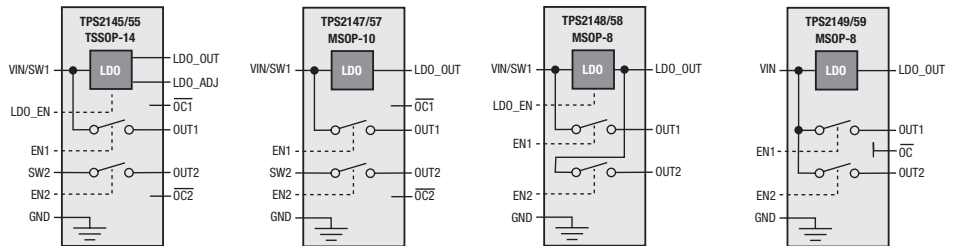

USB High-Power Peripheral Bus Switch + LDO

Device	Switch Voltage	Description
TPS2140	3.3 V	3.3-V, 500-mA switch with active-low enable, 250-mA LDO
TPS2141	5.0 V	5.0-V, 500-mA switch with active-low enable, 250-mA LDO
TPS2150	3.3 V	3.3-V, 500-mA switch with active-high enable, 250-mA LDO
TPS2151	5.0 V	5.0-V, 500-mA switch with active-high enable, 250-mA LDO

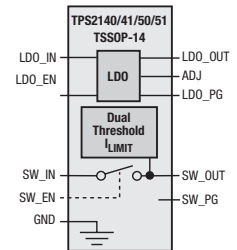

or hybrid USB hubs by incorporating current-limited switches for four ports, a 3.3-V 100-mA LDO, a 5-V LDO controller for self power (TPS2070, TPS2071) and

a DP0 line control to signal an attach to the host.

USB Power Controllers Selection Guide

Device	Application	Number of FETs	Switch Enable	Bus Power Indicator (BPMODE)	V_{IN}		Bus Powered		Self Powered		LDO Controller (A)	LDO	Price*
					(min) (V)	(max) (V)	$r_{DS(on)}$ per FET (typ) (m Ω)	Current Limit (min) (A)	$r_{DS(on)}$ per FET (typ) (m Ω)	Current Limit (min) (A)			
TPS2070	USB 4-port hub	8	L	1L	4.5	5.5	560	0.12	107	0.6	5 V, 3 A	3.3 V, 100 mA	2.55
TPS2071	USB 4-port hub	8	L	1H	4.5	5.5	560	0.12	107	0.6	5 V, 3 A	3.3 V, 100 mA	2.55
TPS2074	USB 4-port hub	8	L	1L	4.5	5.5	500	0.12	100	0.6	—	3.3 V, 100 mA	2.55
TPS2075	USB 4-port hub	8	L	1H	4.5	5.5	500	0.12	100	0.6	—	3.3 V, 100 mA	2.55
TPS2140	USB peripheral	1	L	—	2.7	5.5	70	0.1 and 1.2	—	—	—	Adj. 0.9 to 3.3 V, 250 mA	1.10
TPS2141	USB peripheral	1	L	—	4	5.5	70	0.1 and 1.2	—	—	—	Adj. 0.9 to 3.3 V, 250 mA	1.10
TPS2150	USB peripheral	1	H	—	2.7	5.5	70	0.1 and 1.2	—	—	—	Adj. 0.9 to 3.3 V, 250 mA	1.10
TPS2151	USB peripheral	1	H	—	4	5.5	70	0.1 and 1.2	—	—	—	Adj. 0.9 to 3.3 V, 250 mA	1.10
TPS2145	DSP, PDA	2	L	—	2.9	5.5	340	0.2	—	—	—	3.3 V, 200 mA	1.15
TPS2147	DSP, PDA	2	L	—	2.9	5.5	340	0.2	—	—	—	3.3 V, 200 mA	1.10
TPS2148	USB peripheral	2	L	—	2.9	5.5	340	0.2	—	—	—	3.3 V, 200 mA	0.99
TPS2149	USB 2-port hub	2	L	—	2.9	5.5	340	0.2	—	—	—	3.3 V, 200 mA	0.95
TPS2155	DSP, PDA	2	H	—	2.9	5.5	340	0.2	—	—	—	3.3 V, 200 mA	1.15
TPS2157	DSP, PDA	2	H	—	2.9	5.5	340	0.2	—	—	—	3.3 V, 200 mA	1.10
TPS2158	USB peripheral	2	H	—	2.9	5.5	340	0.2	—	—	—	3.3 V, 200 mA	0.99
TPS2159	USB 2-port hub	2	H	—	2.9	5.5	340	0.2	—	—	—	3.3 V, 200 mA	0.95

*Suggested resale price in U.S. dollars in quantities of 1,000.

Power Multiplexers and ExpressCard™ Power Switches

Power MUX ICs

Power MUX ICs are designed to transition from a main power supply to an auxiliary source when the main supply shuts down (e.g., switching from battery operation to a wall adapter).

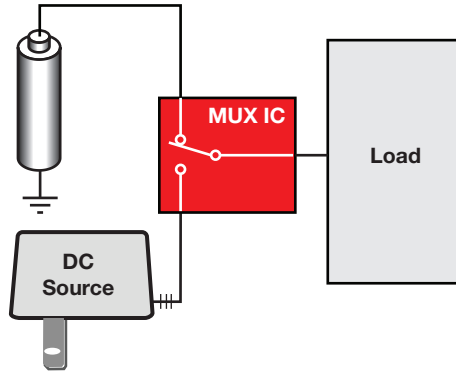

Selection Guide

Device	Number of Inputs	IN1 $r_{DS(on)}$ (m Ω)	IN2 $r_{DS(on)}$ (m Ω)	IN1 Output Current (mA)	IN2 Output Current (mA)	IN1 Supply Current (μ A)	IN2 Supply Current (μ A)	Input Voltage Range (V)	Transition Time		Transition	Price*
									IN1 to IN2 (μ s)	IN2 to IN1 (μ s)		
TPPM0301/2	3	—	—	400	400	2500	250	3 to 5.5	—	—	Autoswitch	1.60
TPPM0303	3	—	—	250	250	2500	250	3 to 5.5	—	—	Autoswitch	1.07
TPS2100/1	2	250	1300	500	10	10	0.75	2.7 to 4.0	4	900	L/H enable	0.59
TPS2102/3	2	250	1300	500	100	14	0.75	2.7 to 4.0	3	700	L/H enable	0.69
TPS2104/5	2	250	1300	500	100	18	0.75	2.7 to 5.5	3	700	L/H enable	0.85
TPS2110A/2A/4A	2	120	120	312 to 750	312 to 750	85	85	2.8 to 5.5	40	40	Autoswitch	0.70
TPS2111A/3A/5A	2	84	84	625 to 1250	625 to 1250	85	85	2.8 to 5.5	40	40	Autoswitch	0.70

*Suggested resale price in U.S. dollars in quantities of 1,000.

Integrated ExpressCard™ Power Interface Switch

TPS2231

Get samples, datasheets, evaluation modules and app reports at: www.ti.com/sc/device/TPS2231

Key Features

- Meets PC card standard for ExpressCard technology
- TTL-logic compatible inputs
- Short-circuit and thermal protection
- 50- μ A (typ) quiescent current on 3.3-V auxiliary input (single)

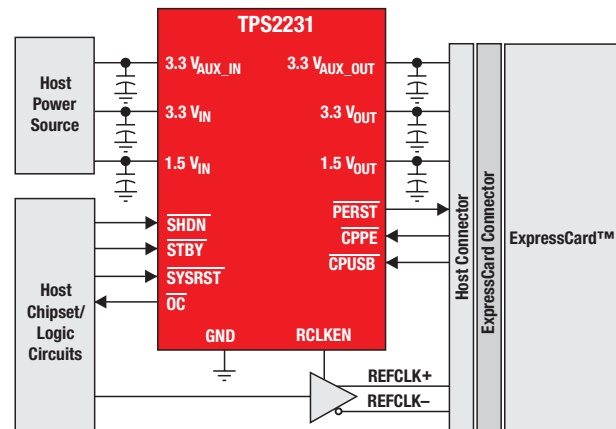

Typical ExpressCard power-distribution application.

USB Current-Limiting Switches



USB Current-Limiting Power Switches

Power switches are used to intelligently turn power on/off and provide fault protection. They are ideal for power sequencing or segmentation and when controlled allocation of power is needed to circuit blocks, modules, add-in cards or cabled connections.

Universal Serial Bus (USB) ports are great examples of where this intelligent protection is vital for protecting your power supply and achieving regulatory compliance. TI's family of low-cost power switches are ideal for USB port designs.

To minimize voltage drop, select devices with the lowest $r_{DS(on)}$ or Drain-to-Source on-resistance.

TPS2500/1 Boost + USB Switch

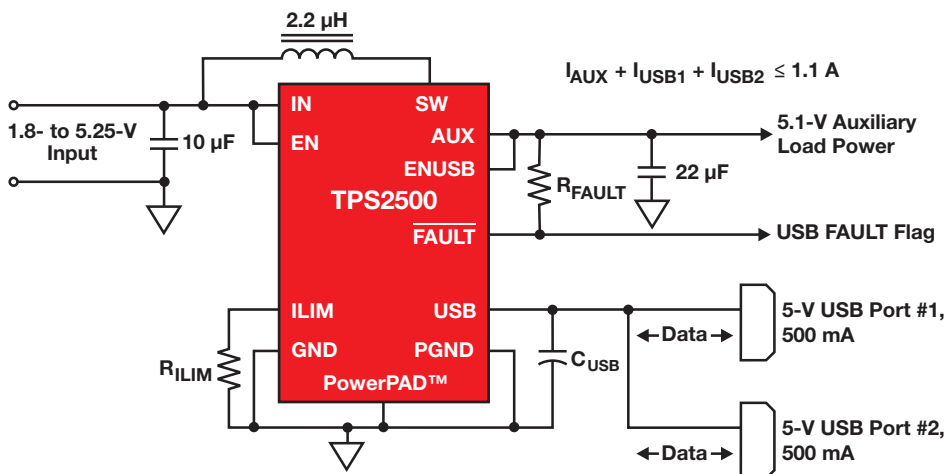

The TPS2500/1 combines a boost converter and a current-limiting switch for USB applications where the 5-V rail is not available. It is also ideal for devices with 1.8-V, 2.5-V or 3.3-V rails.

Current-Limited Switch Matrix

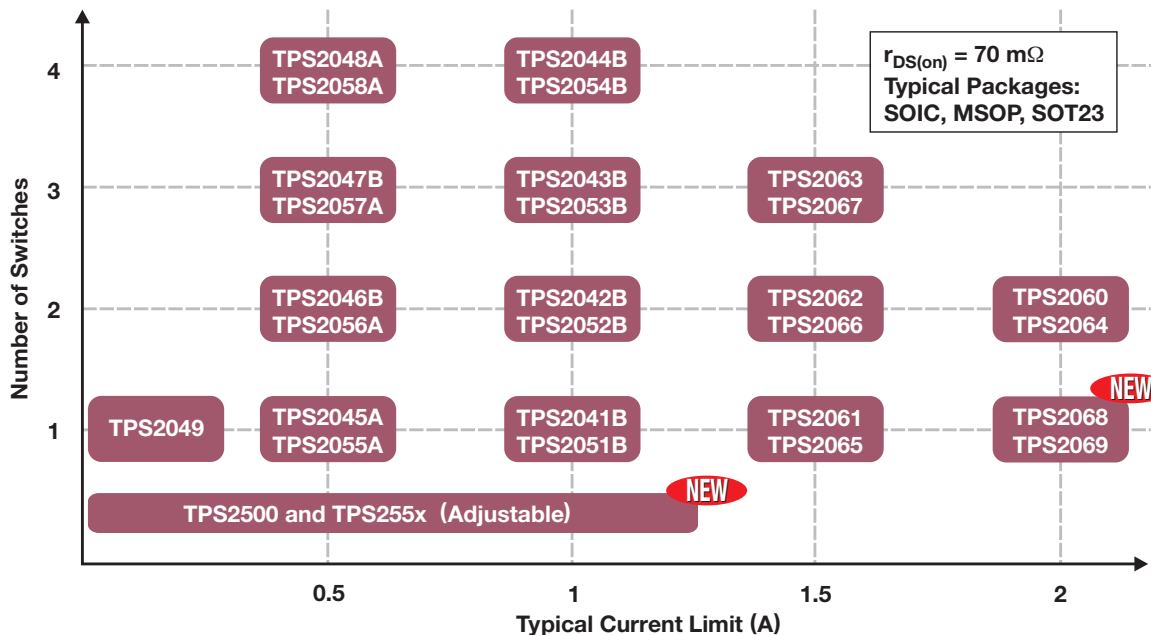



USB Current-Limiting Switches

Selection Guide

Device	Number of FETs	I _{OS} (min) (A)	r _{DS(on)} (mΩ)	V _{IN} Range (V)	Supply Current (μA)	OC Logic Output	OT Logic Output	Enable	Predecessor	Price*
TPS2010A	1	0.22	30	2.7 to 5.5	73	No	No	L	TPS2010	0.75
TPS2011A	1	0.66	30	2.7 to 5.5	73	No	No	L	TPS2011	0.75
TPS2012A	1	1.1	30	2.7 to 5.5	73	No	No	L	TPS2012	0.75
TPS2013A	1	1.65	30	2.7 to 5.5	73	No	No	L	TPS2013	0.75
TPS2020/30	1	0.22	33	2.7 to 5.5	73	Yes	Yes	L/H	—	1.05
TPS2021/31	1	0.66	33	2.7 to 5.5	73	Yes	Yes	L/H	TPS2014	1.05
TPS2022/32	1	1.1	33	2.7 to 5.5	73	Yes	Yes	L/H	TPS2015	1.05
TPS2023/33	1	1.65	33	2.7 to 5.5	73	Yes	Yes	L/H	—	1.05
TPS2024/34	1	2.2	33	2.7 to 5.5	73	Yes	Yes	L/H	—	1.05
TPS2041B/51B	1	0.7	70	2.7 to 5.5	43	Yes	Yes	L/H	TPS2041/51/41A/51A	0.45
TPS2042B/52B	2	0.7 ea	70	2.7 to 5.5	50	Yes	Yes	L/H	TPS2042/52/42A/52A	0.60
TPS2043B/53B	3	0.7 ea	70	2.7 to 5.5	65	Yes	Yes	L/H	TPS2043/53/43A/53A	0.90
TPS2044B/54B	4	0.7 ea	70	2.7 to 5.5	75	Yes	Yes	L/H	TPS2044/54/44A/54A	1.00
TPS2045A/55A	1	0.3	80	2.7 to 5.5	80	Yes	Yes	L/H	TPS2045/55	0.40
TPS2046B/56A	2	0.3 ea	80	2.7 to 5.5	80	Yes	Yes	L/H	TPS2046/46A/56	0.60
TPS2047B/57A	3	0.3 ea	80	2.7 to 5.5	160	Yes	Yes	L/H	TPS2047/47A/57	0.90
TPS2048A/58A	4	0.3 ea	80	2.7 to 5.5	160	Yes	Yes	L/H	TPS2048/58	1.00
TPS2049	1	0.1	400	2.7 to 5.5	43	Yes	Yes	L	TPS2041/51/41A/51A	0.50
TPS2550/51	1	0.1 to 1.1	85	2.5 to 6.5	130	Yes	Yes	L/H	—	0.65
TPS2552/53	1	0.75 to 1.3	85	2.5 to 6.5	120	Yes	Yes	L/H	—	0.70
TPS2552-1/53-1	1	0.75 to 1.3	85	2.5 to 6.5	120	Yes	Yes	L/H	—	0.70
TPS2556/57	1	0.5 to 5	24	2.5 to 6.5	130	Yes	Yes	L/H	—	0.90
TPS2560/61	2	0.25 to 2.5	48	2.5 to 6.5	130	Yes	Yes	L/H	—	0.90
TPS2590	1	1 to 5	28	3 to 20	35	Yes	No	L	—	1.05
TPS2060/4	2	1.5 ea	70	2.7 to 5.5	50	Yes	Yes	L/H	—	1.20
TPS2061/5	1	1.1	70	2.7 to 5.5	43	Yes	Yes	L/H	—	0.60
TPS2062A/6	2	1.1 ea	70	2.7 to 5.5	50	Yes	Yes	L/H	TPS2062	0.75
TPS2063/7	3	1.1 ea	70	2.7 to 5.5	65	Yes	Yes	L/H	—	0.90
TPS2068/9	1	1.5	70	2.7 to 5.5	43	Yes	Yes	L/H	—	0.60
TPS2080/1/2 ¹	2	0.7 ea	80	2.7 to 5.5	85	Yes	Yes	2H, 1L/1H, 2L	—	0.65
TPS2085/6/7 ¹	4	0.7 ea	80	2.7 to 5.5	85	Yes	Yes	4H, 2L/2H, 4L	—	1.05
TPS2090/1/2 ¹	2	0.3 ea	80	2.7 to 5.5	85	Yes	Yes	2H, 1L/1H, 2L	—	0.65
TPS2095/6/7 ¹	4	0.3 ea	80	2.7 to 5.5	85	Yes	Yes	4H, 2L/2H, 4L	—	1.05

¹ Can be configured as power MUX ICs.

*Suggested resale price in U.S. dollars in quantities of 1,000.



Design Factors

Manual Reset (MR) — This feature allows the user to manually reset the circuit or control the supervisory circuit by another device of the application.

Watchdog Input (WDI) — In situations where the system processor may not be functioning properly, its onboard watchdog feature may fail to reset. Supervisors with integrated watchdog functionality increase system reliability by being able to trigger a reset.

Active High Output — Allows the use of processors with active high reset input without additional components.

Delay Time — Allows the voltage and other components in the circuit to stabilize first before the normal operation starts again.

Open Collector — Same as open drain, but the RESET output is connected to the collector of the internal transistor.

Open Drain — The RESET output of the supervisory circuit is connected to the drain of the internal MOSFET. Choose an open-drain reset output supervisor when more than one supervisor is connected on the bus.

Push-Pull — A push-pull reset output supervisor is recommended when only one supervisor is needed on the bus. This eliminates the need for a pull-up resistor and offers higher speed.

Quad Supervisor with Programmable Delay and Watchdog Timer

TPS386000/20/40/60

NEW

Get samples at: www.ti.com/sc/device/TPS386000

The TPS3860xx family can monitor four power rails that are greater than 0.4 V with a 0.25% threshold accuracy. With external resistors, the threshold of each SVS can be programmed. Each SVS has a programmable delay circuit, and the delay time can be set from 1.25 ms to 10 s. The quiescent current is very low with 12 μ A (typical). Available in a small 4x4-mm, 20-pin QFN package. Options:

- TPS386000: Open-Drain $\overline{\text{RESET}}$ and $\overline{\text{WDO}}$
- TPS386020: Open-Drain $\overline{\text{RESET}}$ and $\overline{\text{WDO}}$
- TPS386040: Push-Pull $\overline{\text{RESET}}$ and $\overline{\text{WDO}}$
- TPS386060: Push-Pull $\overline{\text{RESET}}$ and $\overline{\text{WDO}}$

Supervisory Circuits, Reset ICs and Sequencers Family of Products

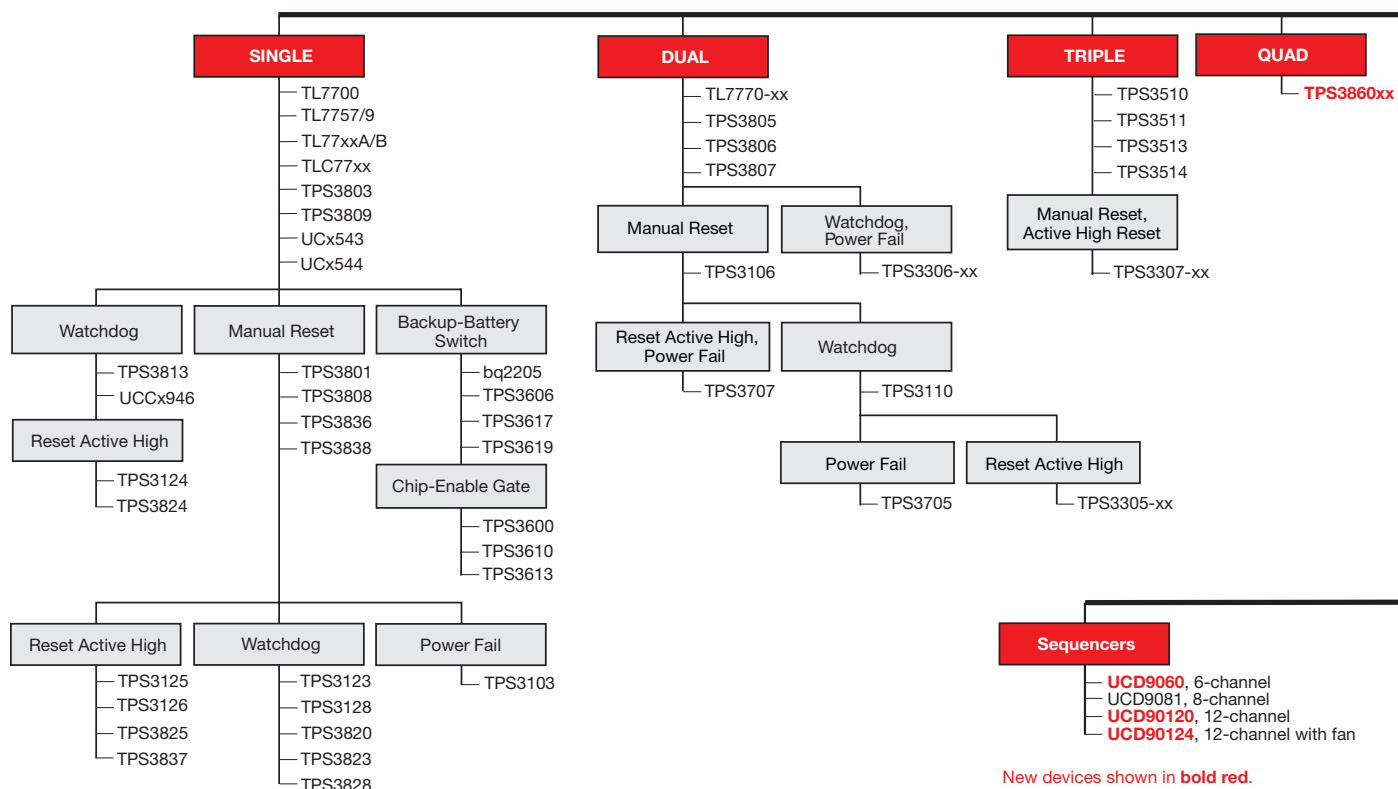



Power-Supply Sequencer UCD90120/4

NEW

Get samples at: www.ti.com/sc/device/UCD90120

The UCD90120/4 Power Supply Sequencer and System Health Controller sequences up to 12 independent voltage rails. The devices integrate a 12-bit, 200-ksp/s ADC with a 1% accurate internal reference for monitoring up to 13 inputs for power supply voltage, current, or temperature. There are 26 GPIO pins that can be used for power supply enables, power-on reset signals, or other system functions. Also, 12 of the 26 GPIO pins can be used as PWM outputs for power supply margining, fan control (UCD90124 only), or general-purpose PWM functions including multiphase clock generation for switch-mode power supplies. Both devices offer non-volatile fault logging for capturing power supply faults, peak rail voltages, and other important data that can aid in system failure analysis. JTAG and PMBus interfaces provide options for preproduction and in-system configuring and monitoring. The TI Fusion Digital Power Designer is provided for device configuration. This PC-based graphical user interface offers an intuitive interface for configuring, storing, and monitoring all system operating parameters.

Features

Sequence

- Sequence up to 12 rails on and off
- Dependencies on time, parent rails, GPs, and I²C

- Independent turn-on and turn-off configurations
- Flexible GPIO for enables, power goods, and more
- Boolean logic builder

Monitor

- Respond to faults by configuring retries, shutdown delays, and slave rails to shutdown
- User settable scale factors convert to actual system units including voltage, current, and temperature
- 6 optional comparators for fault response in < 60 μs

- Nonvolatile fault logging

Margin

- Simultaneously margin up to 10 rails using PWM outputs
- Support for open-loop or closed-loop methods
- Command rails high and low using I²C or GPIO pins
- All unused margining outputs can be used as GPIO

Fan control (UCD90124 only)

- Monitor and control up to 4 fans (2-, 3-, or 4-wire fans)

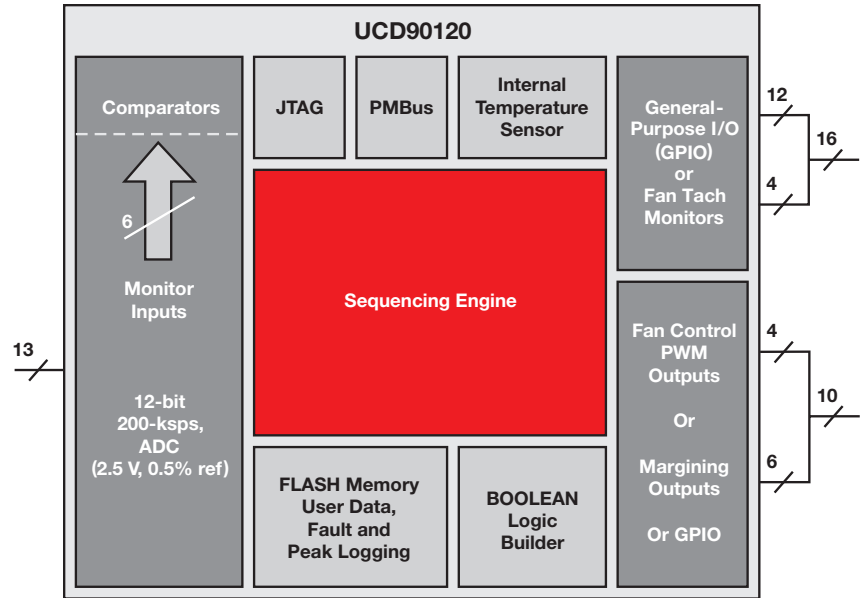

Typical application for UCD90120 sequencer.

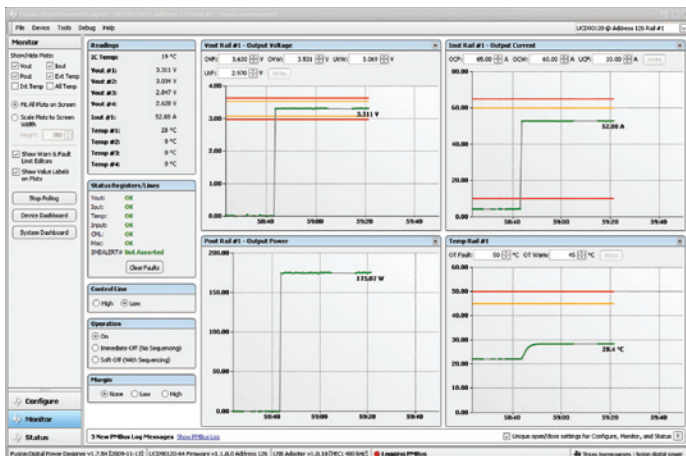

Monitoring.

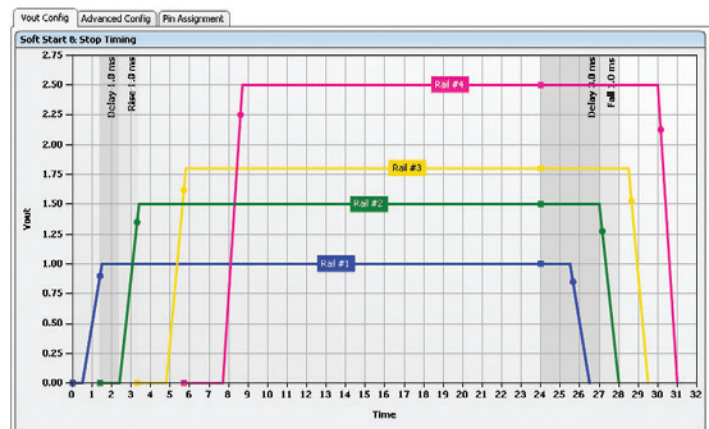

Sequencing.



Selection Guide

Device	Number of Supervisors	Supervised Voltages	Package(s)	V _{DD} Range (V)	I _{DD} (typ) (µA)	Time Delay (ms)	Watchdog Timer WDI (sec)	Reset Threshold Accuracy (%)	Manual Reset Input/MR	Active-Low Reset Output	Active-High Reset Output	Reset Output Topology ¹	Power-Fail PF/PFO	Overvoltage Detection	Overcurrent Detection	Backup-Battery Switchover	Chip-Enabled Gating	HiRel (H) or Automotive (A) [†]	Comments	Price*
General Purpose Supply Supervisors																				
TPS3808	1	Adj./0.9/1.2/1.5/1.8/2.5/3.0/3.3/5.0/EEPROM	SOT-23, SON	1.8 to 6.5	2.4	Prog	—	0.5	✓	✓		OD						H, A		0.70
TPS3818	1	2.5/EEPROM	SOT-23, SON	1.8 to 6.5	2.4	Prog	—	0.5	✓	✓		OD							High accuracy delay	0.95
TPS3103	1	1.2/1.5/2.0/3.3	SOT-23	0.4 to 3.3	1.2	130	—	0.75	✓	✓		OD	✓							0.90
TPS3123	1	1.2/1.5/1.8	SOT-23	0.75 to 3.3	14	180	1.4	3.6	✓	✓		PP								0.85
TPS3124	1	1.2/1.5/1.8	SOT-23	0.75 to 3.3	14	180	1.4	3.6	✓	✓	✓	PP								0.85
TPS3125	1	1.2/1.5/1.8/3.0	SOT-23	0.75 to 3.3	14	180	—	3.6	✓	✓	✓	PP								0.80
TPS3126	1	1.2/1.5/1.8	SOT-23	0.75 to 3.3	14	180	—	3.5	✓	✓	✓	OD								0.80
TPS3128	1	1.2/1.5/1.8	SOT-23	0.75 to 3.3	14	180	1.4	3.5	✓	✓		OD								0.85
TPS3800	1	2.7	SC-70	1.6 to 6.0	9	100	—	2	✓	✓		PP								0.40
TPS3801	1	Adj./1.8/2.5/3.0/3.3/5.0	SC-70	1.6 to 6.0	9	200	—	2	✓	✓		PP								0.40
TPS3802	1	3.0/3.3	SC-70	1.6 to 6.0	9	400	—	2	✓	✓		PP								0.40
TPS3803	1	Adj./1.5	SC-70	1.3 to 6.0	3	—	—	1.5		✓		OD						H, A	Voltage detector	0.25
TPS3809	1	2.5/3.0/3.3/5.0	SOT-23	2.0 to 6.0	9	200	—	2.2		✓		PP						H, A		0.25
TPS3813	1	2.5/3.0/3.3/5.0	SOT-23	2.0 to 6.0	9	25	Window	2.2		✓		OD						H, A	Window Watchdog	0.90
TPS3820/8-xx	1	3.3/5.0	SOT-23	1.1 to 5.5	15	25/200	0.2/1.6	2.4	✓	✓		PP/OD						A		0.65
TPS3823	1	2.5/3.0/3.3/5.0	SOT-23	1.1 to 5.5	15	200	1.6	2.4	✓	✓		PP						A		0.65
TPS3824-xx	1	2.5/3.0/3.3/5.0	SOT-23	1.1 to 5.5	15	200	1.6	2.2		✓	✓	PP						A		0.65
TPS3825-xx	1	3.3/5.0	SOT-23	1.1 to 5.5	15	200	—	2.2	✓	✓	✓	PP						A		0.55
TPS3836/8	1	1.8/2.5/3.0/3.3	SOT-23	1.6 to 6.0	0.22	10/200	—	2.5	✓	✓		PP/OD						H, A		0.85
TPS3837	1	1.8/2.5/3.0/3.3	SOT-23	1.6 to 6.0	0.22	10/200	—	2.4	✓	✓	✓	PP						H, A		0.85
TL7700	1	Adjustable	DIP-8, SOP-8	1.8 to 40	0.6 mA	Prog	—	1		✓		OC								2.25
TL7757	1	5	SO-8, SOT-89, TO-92	1.0 to 7.0	1.4 mA	—	—	2.6		✓		OC						H		0.32
TL7759	1	5	SO-8	1.0 to 7.0	1.4 mA	—	—	2.6		✓	✓	OC								0.88
TL77xxA/B	1	2.7/3.3/5.0/12/15	SO-8, DIP-8, SOP-8	3.5 to 18	1.8 mA	Prog	—	2	✓	✓	✓	OC						H		0.25
TL77xx	1	Adj./2.5/3.3/3.0/5.0	SO-8, DIP-8, TSSOP-8	2.0 to 6.0	9	Prog	—	5.5		✓	✓	PP						H, A		0.65
UCCx946	1	Adjustable	SO-8, DIL-8, TSSOP-8	2.0 to 5.5	10	Prog	Prog	2		✓		PP						A		1.75
TPS3807	2	3/3.5	SC-70	1.8 to 6.5	3.5	20	—	1		✓		OD								0.95
TPS3106	2	Adj./0.9/1.6/3.3	SOT-23	0.4 to 3.3	1.2	130	—	0.75	✓	✓		OD						H		0.90
TPS3110	2	Adj./0.9/1.2/1.5/3.3	SOT-23	0.4 to 3.3	1.2	130	1.1	0.75	✓	✓		PP								0.99
TPS3305-xx	2	1.8/2.5/3.3/5.0	SO-8, MSOP-8	2.7 to 6.0	15	200	1.6	2.7	✓	✓	✓	PP								1.00
TPS3306-xx	2	1.5/1.8/2.0/2.5/3.3/5.0	SO-8, MSOP-8	2.7 to 6.0	15	100	0.8	2.7	✓	✓		OD	✓					A		1.05
TPS3705-xx	2	3.0/3.3/5.0	SO-8, MSOP-8	2.0 to 6.0	30	200	1.6	2.1	✓	✓		PP	✓							0.80
TPS3707-xx	2	2.5/3.0/3.3/5.0	SO-8, MSOP-8	2.0 to 6.0	20	200	—	2.2	✓	✓	✓	PP	✓							0.75
TPS3805	2	Adj./3.3	SC-70	1.3 to 6.0	3	—	—	1.5		✓		PP						H, A	Voltage detector	0.34
TPS3806	2	Adj./2.0/3.3	SOT-23	1.3 to 6.0	3	—	—	2		✓		OD							Voltage detector	0.45
TL7770-xx	2	5.0/12.0 & Adj.	SO-16, DIP-16	3.5 to 18	5 mA	Prog	—	2	✓	✓	✓	OC		✓						1.55
TPS3307-xx	3	Adj./1.8/2.5/3.3/5.0	SO-8, MSOP-8	2.0 to 6.0	15	200	—	2.7	✓	✓	✓	PP						A		1.05
TPS3860xx	4	Adj. (includes negative rail)	QFN	1.8 to 6.5	9	Prog	0.6	0.25	✓	✓	✓	PP/OD		✓						1.95
UCD9060	6	Prog. by software GUI	QFN-40	3.3 to 12	50 mA	Prog						Power Supply Sequencer and Monitor							TBD	
UCD9081	8	Prog. by software GUI	QFN-32	3.3	3 mA	Prog						Power Supply Sequencer and Monitor							3.20	
UCD90120	13	Prog. by software GUI	QFN-64	3.3 to 12	50 mA	Prog						Power Supply Sequencer and Monitor							4.95	
UCD90124	13	Prog. by software GUI	QFN-64	3.3 to 12	50 mA	Prog						Power Supply Sequencer and Monitor						With fan control	6.45	
Battery Backup Switchover Supply Supervisors																				
TPS3600	1	2.0/2.5/3.3/5.0	TSSOP-14	1.6 to 5.5	20	100	0.8	2.3	✓	✓		PP	✓			✓	✓			2.15
TPS3606-33	1	3.3	MSOP-10	1.6 to 5.5	20	100	0.8	2	✓	✓		PP	✓			✓	✓			1.45
TPS3610	1	1.8/5.0	TSSOP-14	1.6 to 5.5	20	100	0.8	2	✓	✓		PP	✓			✓	✓			1.80
TPS3613-01	1	Adjustable	MSOP-10	1.6 to 5.5	20	100	—	1.7	✓	✓	✓	PP				✓	✓			1.50
TPS3619	1	3.3/5.0	MSOP-8	1.6 to 5.5	15	100	—	2	✓	✓		PP	✓			✓	✓	H		1.10
Special Function Supply Supervisors																				
bq2205LY	1	3.3	TSSOP-16	3 to 3.6	0.2 mA	—	—	1.7		✓		OD				✓	Two		See Note 2	1.75
TPS3510/1	3	3.3/5.0/12.0	SO-8, DIP-8	4 to 15	1 mA	300	—	9.1		✓		OD	✓	✓					PC Power Supplies	0.45
TPS3513/4	3	3.3/5.0/12.0	SO-14, DIP-14	4.5 to 15	1 mA	300	—	9.1		✓		OD	✓	✓	✓				PC Power Supplies	0.70

¹PP = push-pull, OD = open drain, OC = open collector.

²3.3-V SRAM controller with battery backup.

[†]Devices qualified for HiRel (H) or Automotive (A) applications are available with different pricing. Certain voltage options are not available.

*Suggested resale price in U.S. dollars in quantities of 1,000.

New devices are listed in bold red. Preview devices are listed in bold blue.

Note: Custom voltages can be provided. Minimum order quantities may apply. Contact TI for details and availability.



Design Factors

Topology — Shunt (two-terminal) vs. series (three-terminal). Shunt references are very similar to Zener diodes in operation as both require an external resistor for biasing. The external resistor determines the maximum current that can be supplied to the load as well as provide the minimum biasing current to maintain regulation. Shunt references should be considered when the load is nearly constant and power supply variations are minimal. Series references do not require any external components and they should be considered when the load is variable and lower voltage overhead is of the importance. They are also more immune to the power supply changes than shunt references.

Initial Accuracy — This parameter is of primary concern in systems where calibration is impossible or inconvenient. Usually, it is accomplished by the calibration of the overall system. Initial accuracy

is specified with fixed input voltage and no load current (for series type) or fixed bias current (for shunt type).

Temperature Drift — Temperature drift is the change in output voltage due to the temperature change, expressed in ppm/°C. Buried Zener type references (e.g., REF02, REF102) typically have a lower temperature drift than bandgap type voltage references. Temperature drift can be specified in several ways (slope, butterfly and box), but the most common way is the box method calculated as:

$$TC \left(\frac{\text{ppm}}{^{\circ}\text{C}} \right) = \frac{(V_{\text{max}} - V_{\text{min}}) \times 10^6}{(T_{\text{max}} - T_{\text{min}}) \times V_{\text{nom}}}$$

Long-Term Stability — The output of a voltage reference changes very gradually as time goes by. The greatest change occurs in the first 500 hours. This parameter can be important in high-performance applications or in applications where periodic calibration is not

acceptable. TI specifies long-term stability data based on the observation of over 1000 hours at room temperature.

Output Noise — Output noise is usually specified over two frequency ranges: 0.1 Hz to 10 Hz (peak-to-peak noise) and 10 Hz to 1 kHz (RMS noise). Noise can be important because it can reduce dynamic range of the acquisition system. High-resolution data acquisition systems may experience “dither” in the LSBs solely due to reference noise. Noise can be reduced by external filtering (REF102 has noise reduction pin).

Adjustable Output — Both fixed and adjustable outputs are available. The adjustable output can be set via a resistor divider connected to a reference pin.

Packaging — Through-holes (PDIP and TO-92) and surface mount (SOIC, TSSOP, SOT-89, SOT23 and SC70) packages are available.

Voltage References Family of Products

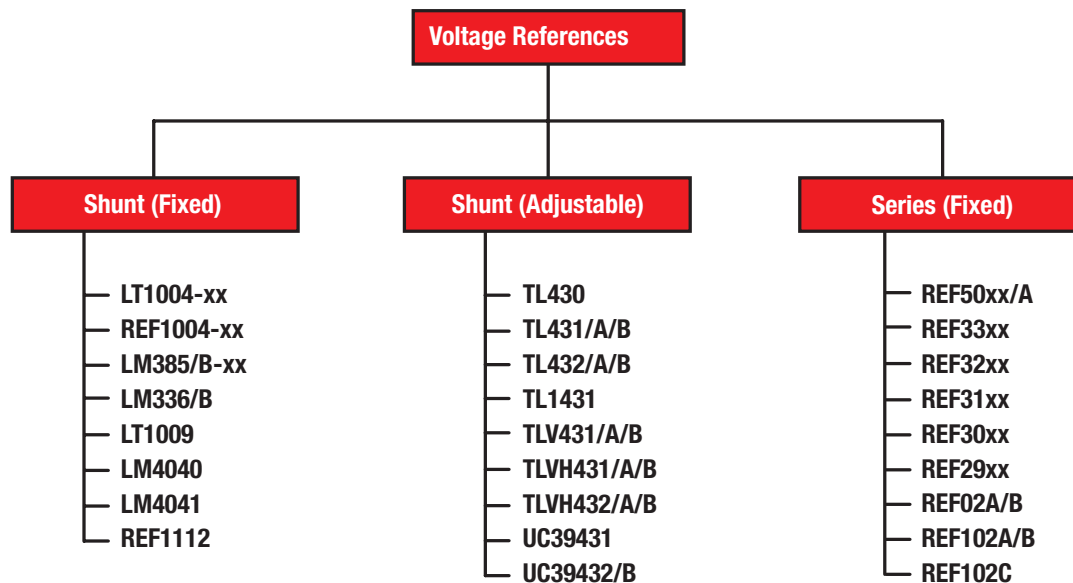

Selection Guide

Device	Number of Channels	V _s		I _q per Channel (max) (mA)	t _{RESP} Low-to-High (μs)	Output Type	V _{IO} (25°C) (max) (mV)	Rail-to-Rail	V _{ref} Fixed (V)	V _{ref} 25°C Tolerance (%)	V _{ref} Temp Co. (typ) (ppm/°C)	Package(s)	Price*
		(min) (V)	(max) (V)										
Comparator with Voltage Reference													
TLV3011	1	1.8	5.5	0.005	6	Open-Drain	12	In, Out	1.242	1	40	SOT23, SC70	0.75
TLV3012	1	1.8	5.5	0.005	6	Push-Pull	12	In, Out	1.242	1	40	SOT23, SC70	0.75

*Suggested resale price in U.S. dollars in quantities of 1,000.



Selection Guide (Continued)

Device	V _{OUT} (V)	Initial Tolerance @ 25°C (%)	Temp. Coefficient		I _{OUT} (max) (mA)	I _Q (max) (mA)	V _{IN}		Package(s)	HiRel (H) or Automotive (A) [†]	Price*
			(typ) (ppm/°C)	(max) (ppm/°C)			(min) (V)	(max) (V)			
Series Voltage References											
REF50xx/A	2.048, 2.5, 3.0, 4.096, 4.5, 5.0	0.05, 0.1	2.5, 3	3, 8	±10	1.0	2.7	18	SOIC	A	1.85
REF33xx	1.25, 1.8, 2.048, 2.5, 3.0, 3.3	0.15	8	30	±5	0.005	1.8	5.5	SC70, SOT23		0.85
REF32xx	1.25, 2.048, 2.5, 3.0, 3.3, 4.096	0.2	4	7	±10	0.12	1.8	5.5	SOT23		1.70
REF31xx	1.25, 2.048, 2.5, 3.0, 3.3, 4.096	0.2	5	15	±10	0.115	1.8	5.5	SOT23		1.10
REF30xx	1.25, 2.048, 2.5, 3.0, 3.3, 4.096	0.2	20	50	25	0.05	1.8	5.5	SOT23		0.59
REF29xx	1.25, 2.048, 2.5, 3.0, 3.3, 4.096	2	35	100	25	0.05	1.8	5.5	SOT23		0.49
REF02A/B	5	0.2, 0.3	4	10, 15	21	1.4	8	40	SOIC, PDIP		1.75
REF102A/B	10	0.05, 0.1	—	5, 10	10	1.4	11.4	36	SOIC, PDIP		1.75
REF102C	10	0.025	—	2.5	10	1.4	11.4	36	SOIC, PDIP		4.85

Device	V _{OUT} (V)	Initial Tolerance @ 25°C (%)	Adj. V _{OUT}		Min I _Z for Reg. (μA)	I _Q (max) (mA)	I _{OUT} /I _Z (max) (mA)	V _{IN}		Temp. Coefficient		Package(s)	HiRel (H) or Automotive (A) [†]	Price*
			(min) (V)	(max) (V)				(typ) (ppm/°C)	(max) (ppm/°C)	(min) (V)	(max) (V)			
Shunt Voltage References														
LM236-2.5, LM336/B-2.5	2.5	2, 4	—	—	400	—	10	—	—	10, 13	33	SOIC, TSSOP, T092		0.40
LM285-xx, LM385/B-xx	1.235, 2.5	1, 1.5, 2, 3	—	—	10, 20	—	20	—	—	20	—	SOIC, TSSOP, T092		0.18
LM4040	2.048, 2.5, 3, 4.096, 5, 10	0.1, 0.2, 0.5, 1	—	—	75	—	20	—	—	15	100, 150	SOT23, SC70, T092		0.27
LM4041	Adj., 1.225	0.1, 0.2, 0.5, 1	1.225	10	75	—	12	—	—	15	100, 150	SOT23, SC70, T092		0.27
LT1004-xx	1.235, 2.5	0.3, 0.8	—	—	10, 20	—	20	—	—	20	—	SOIC, TSSOP, T092		0.40
LT1009	2.5	0.2	—	—	400	—	10	—	—	—	25	SOIC, TSSOP, T092	H	0.41
REF1004-xx	1.235, 2.5	0.3, 0.4	—	—	10, 20	—	20	—	—	20	—	SOIC, PDIP		1.23
REF1112	1.25	0.2	—	—	1	0.005	5	—	—	10	30	SOT23		0.79
TL1431	Adj.	0.4	2.5	36	1000	—	100	—	—	23	114	SOIC, TSSOP, T092	H, A	0.32
TL430	Adj.	5	2.75	30	2000	—	100	—	—	120	—	T092		0.58
TL431/A/B, TL432/A/B	Adj.	0.5, 1, 2	2.495	36	600, 1000	—	100	—	—	34	83	SOIC, PDIP, TSSOP, SOT89, SOT23	H, A A	0.14
TLV431/A/B	Adj.	0.5, 1, 1.5	1.24	6	80	—	15	—	—	39	129	SOIC, SOT23, SC70, T092	A	0.23
TLVH431/A/B, TLVH432/A/B	Adj.	0.5, 1, 1.5	1.24	18	100	—	80	—	—	39	129	SOT23, SC70, SOT89, T092	A	0.27
UC39431	Adj., 2.82, 3.12, 5.1, 7.8, 10.42, 12.24	0.4	2.3	36	800	0.5	100	2.2	36	—	—	SOIC, PDIP		2.33
UC39432/B	Adj., 1.3	0.4, 0.8	2.2	36	800	0.5	100	2.2	36	—	—	SOIC, PDIP		2.09

Device	No. of Outputs	I _{OUT} (μA)	Current Tolerance (max) (%)	Current Match Tolerance (max) (%)	Temp Drift (typ) (ppm/°C)	Voltage Compliance, 1% (V)	Current Mirror Tolerance (max) (%)	Price*
Current References								
REF200	2	100	1	1	25	2.5 to 40	0.5	2.60

Device	Number of Channels	V _S		I _Q per Channel (max) (mA)	V _{IO} (25°C) (max) (mV)	GBW (typ) (MHz)	Single Supply	V _{ref} Fixed (V)	V _{ref} Adj.		V _{ref} 25°C Tolerance (%)	I _{ref} (max) (mA)	Package(s)	Price*
		(min) (V)	(max) (V)						(min) (V)	(max) (V)				
Op Amp with Voltage Reference														
TL103W/A	2	3	36	0.6	4, 3	0.9	Yes	2.5	—	—	0.7, 0.4	100	SOIC8	0.32
TSM104W/A	4	3	36	0.6	5, 3	0.9	Yes	—	2.5	36	0.7, 0.4	100	SOIC, TSSOP	0.32

[†]Devices qualified for HiRel (H) or Automotive (A) applications are available with different pricing. Certain voltage options are not available.

*Suggested resale price in U.S. dollars in quantities of 1,000.



TI's premier power management innovation called NexFET™ technology, combines vertical current flow with a lateral power MOSFET. It provides a low on resistance and requires an extremely low gate charge with industry-standard package outlines—a combination not previously possible with existing silicon platforms.

NexFET technology delivers high performance for both N- and P-channel power MOSFET devices. Designers are able to achieve 90% power supply efficiencies from light to full loads with high output currents and low duty cycles, representing a breakthrough in discrete designs.

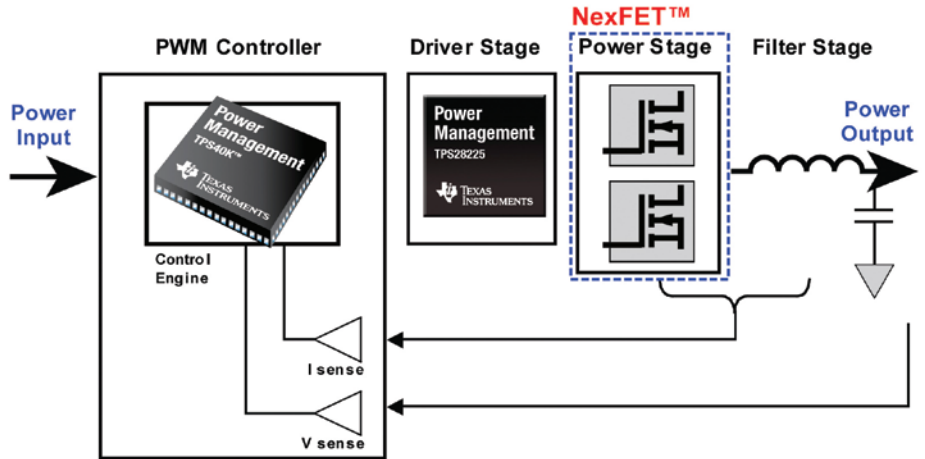

System block diagram of TI electronics in a power system design.

	NexFET™ Technology	Industry Standard
Control FET	$R_{DS(on)} = 5.8 \text{ m}\Omega$	$R_{DS(on)} = 6.6 \text{ m}\Omega$
	$Q_G = 6.5 \text{ nC}$	$Q_G = 12.3 \text{ nC}$
Sync FET	$R_{DS(on)} = 2.5 \text{ m}\Omega$	$R_{DS(on)} = 2.3 \text{ m}\Omega$
	$Q_G = 13.2 \text{ nC}$	$Q_G = 39.8 \text{ nC}$

Technology comparison.

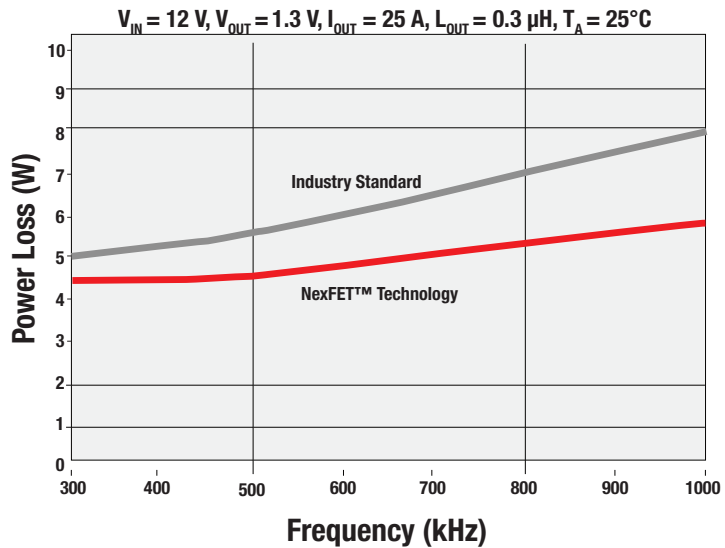

Same power loss, double the frequency.

For additional resources on NexFET™ devices, please visit: www.ti.com/nexfet

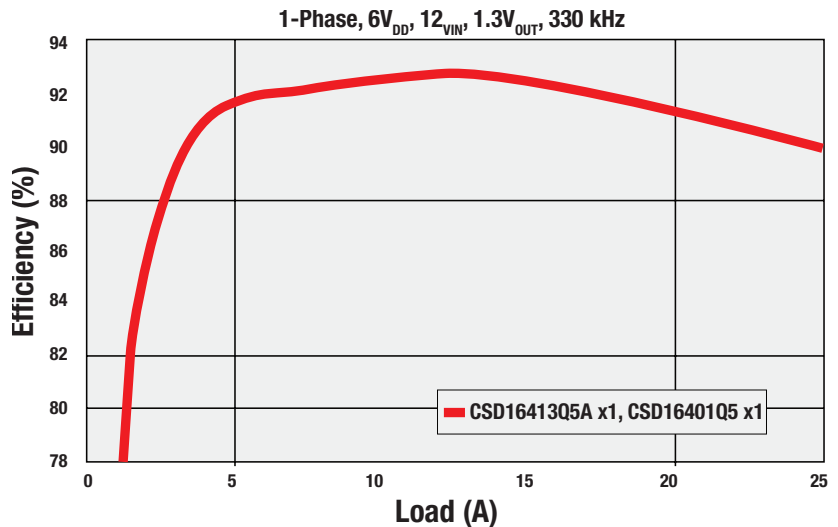

90% efficiency from light to full load.



N-Channel NexFET™ MOSFETs Selection Guide

Device	Package/ Size (mm)	V _{DS}	V _{GS}	Typical R _{DS(on)} (mΩ)				Typical Q _g at 4.5 V (nC)	Typical Q _{gs} (nC)	Typical Q _{gd} (nC)	Typical R _g (Ω)	Typical V _{GS(th)} (V)
				at 10 V	at 4.5 V	at 3 V	at 2.5 V					
CSD16301Q2	QFN/2x2	24	10	—	25	—	33	1.6	0.6	0.3	1	1
CSD16411Q3	QFN/3x3	25	16	8	12	—	—	2.9	1.5	0.7	0.6	2
CSD16409Q3	QFN/3x3	25	16	6.2	9.5	—	—	4	2.1	1	0.6	2
CSD16406Q3	QFN/3x3	25	16	4.2	5.9	—	—	5.8	2.5	1.5	1.4	1.7
CSD16323Q3	QFN/3x3	25	10	—	4.4	5.6	—	6.3	1.7	1.3	1.2	1
CSD16412Q5A	QFN/5x6	25	16	9	13	—	—	2.8	1.3	0.7	0.6	1.8
CSD16410Q5A	QFN/5x6	25	16	6.8	9.6	—	—	3.9	1.8	1.1	0.6	1.9
CSD16404Q5A	QFN/5x6	25	16	4.1	5.7	—	—	6.5	3	1.7	1	1.8
CSD16413Q5A	QFN/5x6	25	16	3.1	4.1	—	—	9	3.5	2.5	0.9	1.6
CSD16403Q5A	QFN/5x6	25	16	2.2	2.9	—	—	13.3	5.5	3.5	1.2	1.6
CSD16407Q5	QFN/5x6	25	16	1.8	2.6	—	—	13.3	5.3	3.5	1.2	1.6
CSD16414Q5	QFN/5x6	25	16	1.5	2.1	—	—	16.6	7.3	4.4	1.3	1.6
CSD16401Q5	QFN/5x6	25	16	1.3	1.8	—	—	21	8.3	5.2	1.1	1.5
CSD16322Q5	QFN/5x6	25	10	—	4.4	5.6	—	6.3	1.7	1.3	1.2	1
CSD16321Q5	QFN/5x6	25	10	—	2.1	2.8	—	14	4	2.5	1.2	1
CSD16325Q5	QFN/5x6	25	10	—	1.7	2.1	—	19	5.2	4	1	1

P-Channel NexFET™ MOSFETs Selection Guide

Device	Package ¹ /Size (mm)	V _{DS} (V)	V _{GS} (V)	Typical R _{DS(on)} (mΩ)				Typical Q _g at 4.5 V (nC)	Typical Q _{gs} (nC)	Typical Q _{gd} (nC)	Typical R _g (Ω)	Typical V _{GS(th)} (V)
				at 4.5 V	at 2.5 V	at 1.8 V	at 1.5 V					
CSD23201W10	WLP/1x1	12	5	66	77	—	110	1.9	0.2	0.4	—	0.6
CSD25301W1015	WLP/1x1.5	20	8	62	80	—	175	2	0.5	0.3	—	0.8
CSD75301W1015 ²	WLP/1x1.5	20	8	80	105	150	—	1.5	0.3	0.3	—	0.7
CSD75205W1015 ²	WLP/1x1.5	20	5	72	94	130	—	1.7	0.3	0.4	30	0.7
CSD75204W15 ²	WLP/1.5x1.5	20	—	50	65	85	—	2.8	0.5	0.6	30	0.7
CSD25301Q2	SON/2x2	20	8	39	56	—	—	2.7	0.6	0.4	0.7	1
CSD25401Q3	SON/3x3	20	12	8.7	13.5	—	—	8.8	201	2.1	1.2	0.9

¹WLP = wafer-level package²Dual FETs with common source.30-V, N-Channel NexFET™ Selection Table — *Coming 1Q 2010*

Device	Package/Size (mm)	BV _{DSS} (V)	V _{GS} (V)	Typical R _{DS(on)} (mΩ)			Typical Q _g at 4.5 V (nC)	Typical Q _{gd} (nC)
				at 8 V	at 4.5 V	at 3 V		
CSD17313Q2	SON/2x2	30	10	23	26	32	1.7	0.4
CSD17309Q3	SON/3x3	30	10	4.1	4.8	6.3	7.6	1.6
CSD17304Q3	SON/3x3	30	10	5.6	6.6	8.7	5	1.1
CSD17308Q3	SON/3x3	30	10	7.8	9.2	12.1	3.6	0.8
CSD17312Q5	SON/5x6	30	10	1.2	1.4	1.8	28	6
CSD17311Q5	SON/5x6	30	10	1.6	1.8	2.3	22.5	4.8
CSD17303Q5	SON/5x6	30	10	1.8	2.1	2.7	18	3.8
CSD17301Q5A	SON/5x6	30	10	2	2.3	2.8	17.5	3.7
CSD17305Q5A	SON/5x6	30	10	2.4	2.8	3.5	13.8	3
CSD17306Q5A	SON/5x6	30	10	2.8	3.3	4.3	11.8	2.5
CSD17310Q5A	SON/5x6	30	10	3.6	4.2	5.5	8.3	1.8
CSD17312Q5A	SON/5x6	30	10	6.2	7.2	9.2	4.9	1
CSD17307Q5A	SON/5x6	30	10	8.2	9.7	13	3.6	0.8

Preview devices are listed in bold blue.



Design Support

A World of Training Options from TI

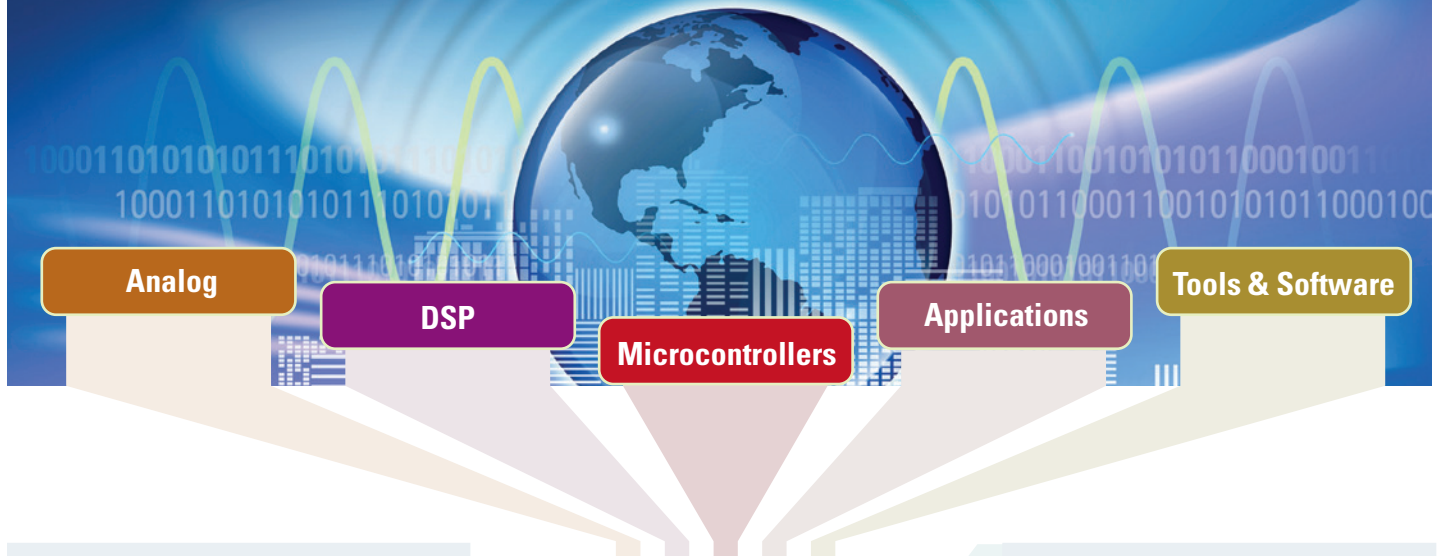
**Power Design Seminars**

TI's popular Power Supply Design Seminar series and Portable Power Seminar series provide rich technical yet practical presentations that combine an array of advanced new power-management concepts, basic design principles and real-world applications examples. Seminar presenters are respected names in the power industry, drawing on decades of experience to discuss today's toughest design issues with innovative techniques, topologies, tools and examples. Keep this link handy to check on dates, times and locations of the Power Seminar series at:

power.ti.com/seminars

Online Training

Videocasts

Seminars

Conferences

1-Day Workshops

Multi-Day Workshops

Online Training and More

You'll find past seminar topics as well as online training modules, videocasts, conferences, workshops and design tools to help you with your design challenges at:

www.ti.com/training





Accelerating and simplifying the engineering process with highly integrated TI analog tools.

www.ti.com/analogelab

Online Power Supply Design Software for TPS40K™, TPS50K (SWIFT™), and TPS60K Controller Families

SwitcherPro™

www.ti.com/switcherpro

Features

- Create new designs with parts included
- Calculate efficiency
- Calculate loop responses
- View stress information on all key parts in the design
- Customize designs by changing part labels, changing parts, and changing outputs
- Change multiple parameters to model all types of what/if cases
- Get a simple schematic for your design
- Send designs to others on the system with your comments attached

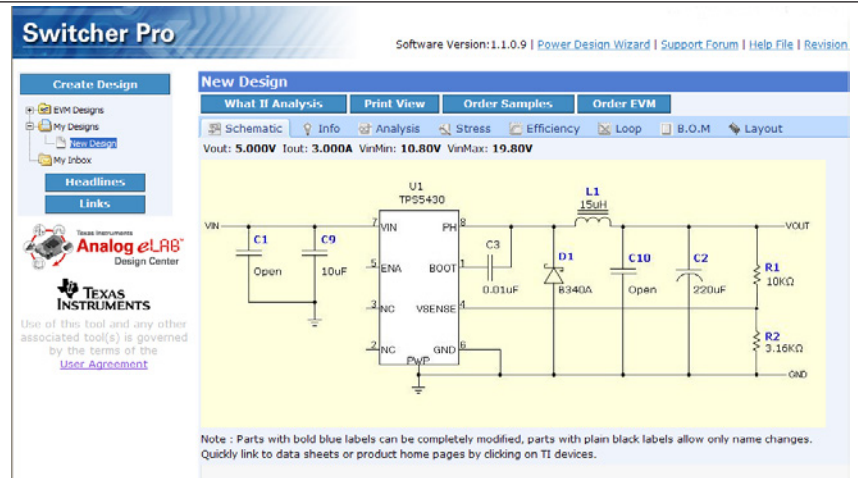

SPICE-Based Analog Simulation Program

TINA-TI™ version 7.0

www.ti.com/tina-ti

TINA is an easy-to-use, but powerful, circuit simulation program based on a SPICE engine. TINA-TI is a fully functional version of TINA, loaded with a library of TI macromodels plus passive and active models.

Features





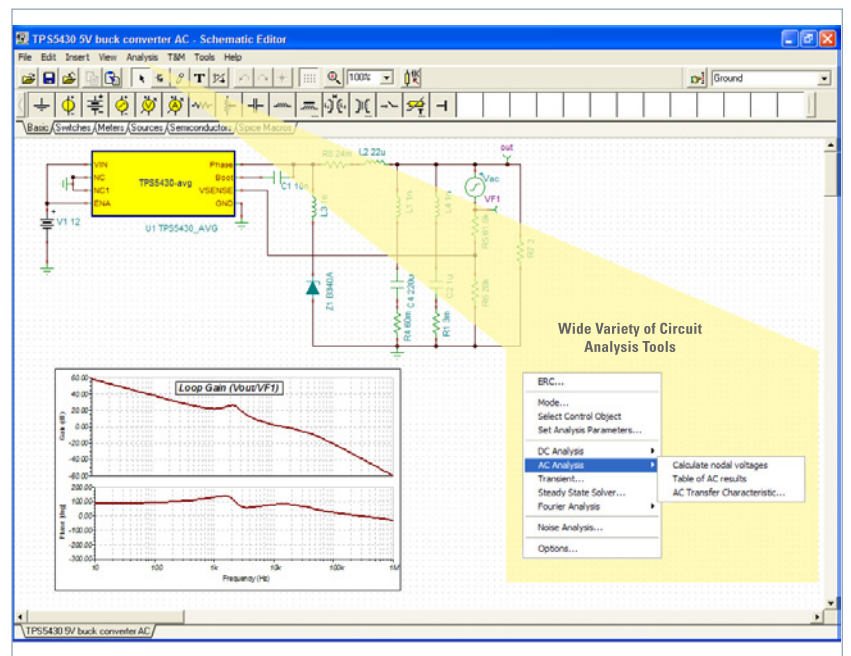





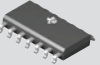

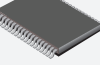

The new TINA-TI version 7.0 has changes from version 6.0 in the following areas:

- TINA-TI provides support for switching power supply devices.
- TINA-TI has no limit to circuit size.
- TINA-TI has more SPICE models and example circuits included.
- User will be notified when an update is available for the tool and TI model library.
- TINA-TI now supports SMPS simulation capability.
- Circuits developed in TINA-TI 7.0 will work with TINA Industrial version 7.
- TINA-TI version 6.0 is forward compatible with version 7.0, but not visa versa

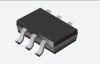

→ Packaging

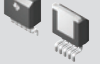





Surface Mount Packages

	Package Type	Package Designator	Key Characteristics
Small Outline Packages			
	Small Outline Integrated Circuit (SOIC)	D, DW, DWU, DTH, DTC, DDA, DVB, DWP	High MSL rating* (MSL1/MSL2), variable size availability
	Mini Small Outline Package (MSOP)	DGK, DGS	Small form factor, thin package
	Heat Sink Small Outline Package (HSOP)	DWP, DWD	Thermally enhanced SOP (low to mid power)
	Small Shrink Outline Package (SSOP)	DL, DB, DF, DBQ, DCE, DCT	High MSL rating* (MSL1/MSL2), higher stand-off height
	Thin Shrink Small Outline Package (TSSOP)	DA, PW, DBT	Variable pin count options available, high MSL rating* (MSL1/MSL2), small form factor
	Exposed Pad Thin Shrink Small Outline Package (HTSSOP)	PWP, DAP, DAD, DCA	Thermally enhanced TSSOP (low to high power); various pin count options available
	Power Small Outline Package (PSOP3)	DKP (slug down), DKD (slug up)	Very high power handling capability, mechanically robust package
Quad Ledged Packages			
	Thin Quad Flat Pack (TQFP)	PFB, PAG, PJT, PBS, PAG	High pin count, leadframe based package
	Exposed Pad Thin Quad Flat Pack (HTQFP)	PAP, PJD, PZP, PHP, PNP, PHD	Thermally enhanced TQFP (mid to high power)
Small Outline Transistors			
	Small Outline Transistor (SC-70)	DCK	Mini form factor
	Small Outline Transistor Package (SOT23)	DBV, DCN, DDC, thin SOT	Small form factor, high MSL rating* (MSL1/MSL2)
	Small Outline Transistor (SOT223)	DCY, DCQ	High MSL rating* (MSL1/MSL2)
	Transistor Outline (TO236)	DBZ	Small form factor
Leaded Packages			
	Plastic Flange Mount Package (DDPak/TO-263)	KTT, KTW	Very high power handling capability
Leadless Packages			
	Small Outline No Leads (SON)	DRB, DRC, DRD, DRK, DRM, DRN, DRT, DSE, DSG, DSJ	Small footprint, thermal package (low to mid power)

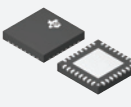
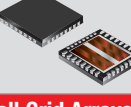
*MSL rating should be checked for individual device.

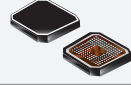

Surface Mount Packages (Continued)

	Package Type	Package Designator	Key Characteristics
Leadless Packages (Continued)			
	Quad Flatpack No Leads (QFN)	RGC, RGE, RGF, RGP, RGT, RGW, RGY, RGZ, RHA, RHB, RHD, RHF, RHH, RHL, RSA, RSB, RSH, RSJ, RSL, RSM, RTE, RTH, RTQ, RTT, RUK, RUV, RVA	Compact footprint, thermal package (mid to high power), available in variable thicknesses
	Flip-Chip Power Packages	RSJ	High power handling capability
Ball Grid Arrays (BGAs)			
	Wafer Chip Scale Package (WCSP)/Die Sized Ball Grid Array (DSBGA)	YEG, YEK, YEJ, YEA, YZA, YED	Die size package, very small form factor, finer pitch
	MicroStar BGA™	ZGU	Controllable count density, variable thickness option availability
	MicroStar Junior™ BGA	ZQE, ZQZ	Smaller sized MicroStar BGA, controllable pin count density
	Picostar™	YFM	Extremely small sized package, ultra-thin, board embeddable
	BGA	ZVD	Very high pin count density

Through-Hole Packages

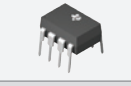
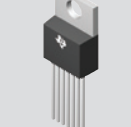
	Package Type	Package Designator	Key Characteristics
	Plastic Dual Inline Package (PDIP)	P, N, NT, NTD	Recommended for wave soldering, excellent board-level reliability
	Transistor Outline (TO220)	KC	Very high power handling capability, recommended for wave soldering, mechanically robust

Package Modules

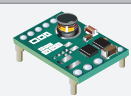
	Package Type	Package Designator	Key Characteristics
	Power Modules	—	Integrated passives, enhanced functionality





How to Connect the PowerPAD™

The PowerPAD should be connected to the appropriate internal signal plane as specified in the product datasheet. Depending on the electrical properties of the thermally conductive epoxy used to connect the Integrated Circuit (IC) to the lead frame, the PowerPAD may have a low impedance connection to the internal signal plane as specified in the product datasheet. Even though the PowerPAD should not be used as your primary signal connection for the IC (use the designated signal pins as specified in the product data sheet), the copper area under the pad can be connected to the specified signal plane per the product data sheet without affecting the device. Since the PowerPAD is intended to remove heat from the part, the size of the signal plane to which the thermal pad is attached within the board should be as large as needed to dissipate the heat. The via array recommendations in the documents below may vary based on layout constraints and recommendations presented in the product datasheet. The documents below should be used as a general guideline for board design while referring to the

product datasheet for application specific via and land pattern requirements.

You can find additional information in the following resources. Technical literature can be accessed online with

www-s.ti.com/sc/techlit/litnumber by replacing *litnumber* with one of the literature numbers shown below in parentheses.

- Remember to check the CAD format for your package under “Symbols/Footprints,” available in all TI Product Folders
- Download the “PowerPAD Made Easy” application brief (SLMA004) in conjunction with the “PowerPAD Thermally Enhanced Package” technical brief (SLMA002)
- Specific information on QFN/SON packages is available in application reports (SLUA271 and SCBA017)
- Visit TI’s Analog & Mixed-Signal KnowledgeBase at: support.ti.com/sc/knowledgebase
- Ask our experts your specific design questions via email by selecting Analog & Mixed-Signal email support in the Contact Tech Support frame at: support.ti.com

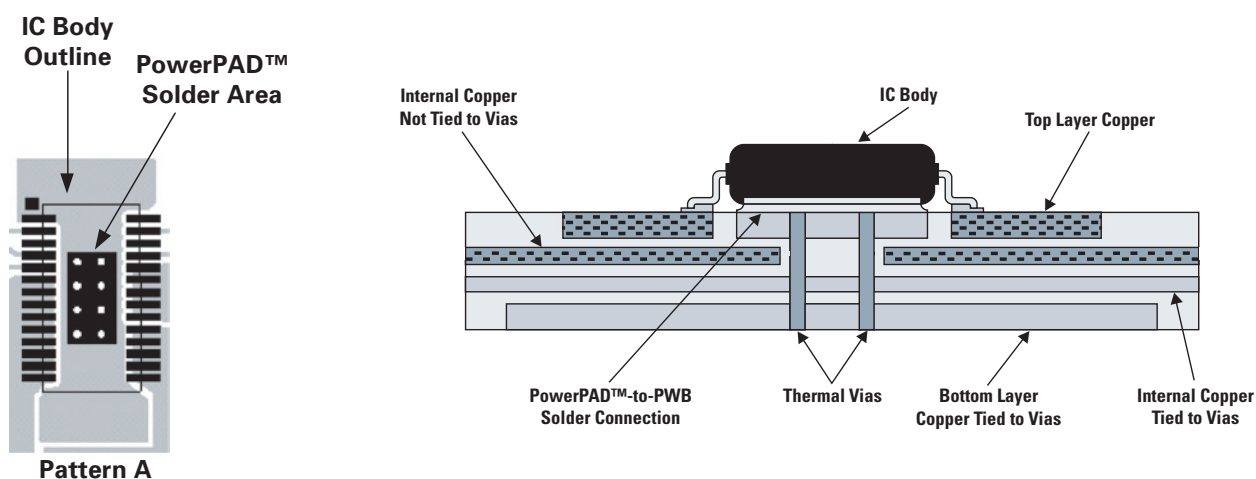

PowerPAD package as used by the SWIFT™ product family.



Device Index

Device	Page	Device	Page	Device	Page	Device	Page
bq2000/T	51	bq26100	55	LM4041	71	PTH12060Y	11, 25, 26
bq2002/C/E/F	51	bq26150	55	LP2950	28	PTMA4	26
bq2004/E/H	51	bq26200	53	LP2981	28	PTN04050A	26
bq2005	51	bq26220	53	LP2985	28	PTN04050C	26
bq2013H	53	bq27000	53	LT1004-xx	71	PTN78000A	26
bq2014H	53	bq27010	53	LT1009	71	PTN78000W/H	26
bq2016	53	bq27200	53	LT1054	39	PTN78020A	26
bq2019	53	bq27210	53	MC34063A	37	PTN78020W/H	26
bq2022A	55	bq27500	53	MC79Lxx/A	30	PTN78060A	26
bq2023	53	bq27501	53	PT4210	26	PTN78060W/H	26
bq2024	55	bq27505	53	PT6910	26	PTQA4	26
bq2031	51	bq27510	53	PTB48500A	26	PTQB4	26
bq2050H	53	bq27520	53	PTB48501A/B	26	PTR08060W	26
bq2052	53	bq27541	53	PTB48502A/B	26	PTR08100W	26
bq2057/C	51	bq27550	53	PTB48520W	26	PTV03010W	26
bq2057T/W	51	bq29312A	54	PTB48540	57	PTV03020W	26
bq2060A	53	bq29330	54	PTB48540A/B/C	26	PTV05010W	26
bq2084	54	bq2941x	54	PTB48560A/B/C	26	PTV05020W	26
bq20z40	52, 53	bq2954	51	PTB78520W	26	PTV08T250W	26
bq20z45	52, 53	bq3060	8	PTB78560A/B/C	26	PTV12010L/W	26
bq20z60	52, 53	bq76PL102	53	PTD08A006W	12, 14	PTV12020L/W	26
bq20z65	52, 53	bq77PL900	54	PTD08A010W	9, 12, 14	REF02A/B	71
bq2205LY	69	bq78PL114	53	PTD08A015W	12, 14	REF1004-xx	71
bq24010	51	CSD16301Q2	73	PTD08A020W	9, 12, 14	REF102A/B	71
bq24012	51	CSD16321Q5	73	PTD08D210W	12, 14	REF102C	71
bq24013	51	CSD16322Q5	73	PTEA4	26	REF1112	71
bq24014	51	CSD16323Q3	73	PTH03000W	25	REF200	71
bq24018	51	CSD16325Q5	73	PTH03010/50/60Y	11	REF29xx	71
bq24020	51	CSD16401Q5	73	PTH03010W	25	REF30xx	71
bq24022	51	CSD16403Q5A	73	PTH03010Y	26	REF31xx	71
bq24023	51	CSD16404Q5A	73	PTH03020W	25	REF32xx	71
bq24024	51	CSD16406Q3	73	PTH03030W	25	REF33xx	71
bq24025	51	CSD16407Q5	73	PTH03050W	25	REF50xx/A	71
bq24026	51	CSD16409Q3	73	PTH03050Y	26	REG710-2.5	39
bq24027	51	CSD16410Q5A	73	PTH03060W	25	REG710-2.7	39
bq24030	51	CSD16411Q3	73	PTH03060Y	25, 26	REG710-3	39
bq24031	51	CSD16412Q5A	73	PTH04000W	25	REG710-3.3	39
bq24032A	51	CSD16413Q5A	73	PTH04040W	25	REG710-5	39
bq24035	51	CSD16414Q5	73	PTH04070W	25	REG71050	39, 44
bq24038	51	CSD17301Q5A	73	PTH04T220/221W	25	REG71055	39
bq24040	51	CSD17303Q5	73	PTH04T230/231W	25	REG711-2.5	39
bq24050	50, 51	CSD17304Q3	73	PTH04T240/241W	25	REG711-2.7	39
bq24060	51	CSD17305Q5A	73	PTH04T260/261W	25	REG711-3	39
bq24061	51	CSD17306Q5A	73	PTH05000W	25	REG711-3.3	39
bq24064	51	CSD17307Q5A	73	PTH05010/50/60Y	11	REG711-5	39
bq24072	51	CSD17308Q3	73	PTH05010W	25	TCA6507	44
bq24073	51	CSD17309Q3	73	PTH05010Y	26	TL103W/A	71
bq24074	51	CSD17310Q5A	73	PTH05020W	25	TL1431	71
bq24075/T	51	CSD17311Q5	73	PTH05030W	25	TL1451A	32
bq24079/T	51	CSD17312Q5	73	PTH05050W	25	TL1963A	28
bq24080	51	CSD17312Q5A	73	PTH05050Y	26	TL2575	35
bq24081	51	CSD17313Q2	73	PTH05060W	25	TL2575HV	35
bq24083	51	CSD23201W10	73	PTH05060Y	25, 26	TL317L/M	30
bq24090	51	CSD25301Q2	73	PTH05T210W	25	TL3842B/3B/4B/5B	20, 21
bq24100/8	51	CSD25301W1015	73	PTH08000W	25	TL4242	46
bq24103/113	51	CSD25401Q3	73	PTH08080W	25	TL430	71
bq24105/115	51	CSD75204W152	73	PTH08T210W	9, 25	TL431A/B	71
bq24300/4/5	50	CSD75205W10152	73	PTH08T220/221W	25	TL432A/B	71
bq24305/8	50	CSD75301W10152	73	PTH08T230/231W	6, 9, 10, 25	TL494	20, 21
bq24314/A	50	DCH01_D	26	PTH08T240/241W	10, 25	TL497A	37
bq24315	50	DCH01_S	26	PTH08T240F	6, 25	TL499A	37
bq24316	50	DCP01_B	26	PTH08T250W	25	TL5001	32
bq24350/2	50	DCP01_DB	26	PTH08T260/261W	25	TL594	20, 21
bq24380	50	DCP02	26	PTH12000L/W	25	TL598	20, 21
bq24381	50	DCP02_D	26	PTH12010/50/60Y	11	TL7660	39
bq24382	50	DCR01	26	PTH12010L/W	25	TL7700	69
bq24450	51	LM236-2.5	71	PTH12010Y	26	TL7757	69
bq24705	51	LM237, LM337	30	PTH12020L/W	25	TL7759	69
bq24721C	51	LM285-xx	71	PTH12030L/W	26	TL7770-xx	69
bq24747	51	LM317, LM317M	30	PTH12040W	26	TL77xxA/B	69
bq24750A/51B	51	LM336/B-2.5	71	PTH12050L/W	26	TL780-xx	30
bq24751A	8	LM385/B-xx	71	PTH12050Y	26	TL783	30
bq25010/2/5/7	51	LM4040	71	PTH12060L/W	26	TLC59108	46

Device Index (Continued)



Device	Page	Device	Page	Device	Page	Device	Page
TLC59108F	46	TPS2102/3	64	TPS2412/3	60	TPS3809	69
TLC59116	46	TPS2104/5	64	TPS2420	60	TPS3813	69
TLC59116F	46	TPS2110A/2A/4A	64	TPS2421-1	60	TPS3818	69
TLC5916	46	TPS2111A/3A/5A	64	TPS2421-2	60	TPS3820/8-xx	69
TLC5917	46	TPS2140	63	TPS2458	60	TPS3823	69
TLC59208F	46	TPS2141	63	TPS2459	59, 60	TPS3824-xx	69
TLC5921	46	TPS2145	63	TPS2480	60	TPS3825-xx	69
TLC59210	46	TPS2147	63	TPS2481	60	TPS3836/8	69
TLC59211	46	TPS2148	63	TPS2490	60	TPS3837	69
TLC59212	46	TPS2149	63	TPS2491	60	TPS3860xx	67, 69
TLC59213/A	46	TPS2150	63	TPS2550/51	66	TPS40000/2	31
TLC5922	46	TPS2151	63	TPS2552	60, 66	TPS40007/9	31
TLC5923	46	TPS2155	63	TPS2552-1	60, 66	TPS40020/21	31
TLC5924	46	TPS2157	63	TPS2552-1/53-1	66	TPS40040	31
TLC5925	46	TPS2158	63	TPS2552/53	66	TPS40041	31
TLC5926	46	TPS2159	63	TPS2553	60	TPS40042	11, 31
TLC5927	46	TPS22901	62	TPS2553-1	60	TPS40054/55/57	31
TLC5928	46	TPS22902	62	TPS2556/57	66	TPS40056	11, 31
TLC5930	46	TPS22902B	62	TPS2560/61	66	TPS40060/61	31
TLC5940	46	TPS22903	62	TPS2590	60, 66	TPS40075	31
TLC5941	46	TPS22906	62	TPS2811	23	TPS40077	31
TLC5942	46	TPS22907	62	TPS2812	23	TPS40090	32
TLC5943	46	TPS22913B	62	TPS2813	23	TPS40091	32
TLC5944	46	TPS22921	62	TPS2814	23	TPS40100	31
TLC5945	46	TPS22922	62	TPS2815	23	TPS40101	31
TLC5946	46	TPS22922B	62	TPS2816	23	TPS40120	32
TLC59461	46	TPS22924C	62	TPS2817	23	TPS40131	32
TLC5947	46	TPS22929B	62	TPS2818	23	TPS40132	32
TLC5951	45, 46	TPS22929D	62	TPS2819	23	TPS40140	32
TLC5952	46	TPS22932B	62	TPS28225	23	TPS40180	32
TLC77xx	69	TPS22941	62	TPS28226	23	TPS40190	31
TLV1117-xx	28	TPS22942	62	TPS2828	23	TPS40192/3	31
TLV3011	70	TPS22943	62	TPS2829	23	TPS40195	31
TLV3012	70	TPS22944	62	TPS2830	23	TPS40200	31
TLV431/A/B	71	TPS22945	62	TPS2831	23	TPS40210/1	32
TLV700xx	28	TPS22946	62	TPS2832	23	TPS40222	35
TLVH431/A/B	71	TPS22949	62	TPS2833	23	TPS43000	32
TLVH432/A/B	71	TPS22949A	62	TPS2834	23	TPS51020	11, 32
TPPM0110/1	29	TPS22951	62	TPS2835	23	TPS5110	32
TPPM0301/2	64	TPS22960	62	TPS2836	23	TPS51100	8, 10, 11, 29, 32
TPPM0303	64	TPS2300/01	60	TPS2837	23	TPS51103	29
TPS2010A	66	TPS2310/11	60	TPS2838	23	TPS51113/63	31
TPS2011A	66	TPS2320/21	60	TPS2839	23	TPS51116	11, 32
TPS2012A	66	TPS2330/31	60	TPS2848	23	TPS51117	32
TPS2013A	66	TPS2342	60	TPS2849	23	TPS51120/A/21/22	8, 32
TPS2020/30	66	TPS2343	60	TPS3103	69	TPS51123	32
TPS2021/31	66	TPS2350	60	TPS3106	69	TPS51124	8, 32
TPS2022/32	66	TPS2358	60	TPS3110	69	TPS51125	32
TPS2023/33	66	TPS2359	60	TPS3123	69	TPS51200	9, 11, 32
TPS2024/34	66	TPS2363	60	TPS3124	69	TPS51217/8	32
TPS2041B/51B	66	TPS2375	57	TPS3125	69	TPS51220	32
TPS2042B/52B	66	TPS2375-1	57	TPS3126	69	TPS5124	31
TPS2043B/53B	66	TPS23750	56, 57	TPS3128	69	TPS5130	32
TPS2044B/54B	66	TPS23753A	55-57	TPS3305-xx	69	TPS51315	35
TPS2045A/55A	66	TPS23754	56, 57	TPS3306-xx	69	TPS51511	32
TPS2046B/56A	66	TPS23756	56, 57	TPS3307-xx	69	TPS51513	32
TPS2047B/57A	66	TPS23757	56, 57	TPS3510/1	69	TPS51610/11	8, 32
TPS2048A/58A	66	TPS2376	57	TPS3513/4	69	TPS51620/21	32
TPS2049	66	TPS2376-H	57	TPS3600	69	TPS51727	32
TPS2060/4	66	TPS2377	57	TPS3606-33	69	TPS53114	31
TPS2061/5	66	TPS2377-1	57	TPS3610	69	TPS53124	31
TPS2062A/6	66	TPS23770	57	TPS3613-01	69	TPS53125/26/27	31
TPS2063/7	66	TPS2384	56, 57	TPS3619	69	TPS54010	35
TPS2068/9	66	TPS23841	57	TPS3705-xx	69	TPS54040	35
TPS2070	63	TPS2390	60	TPS3707-xx	69	TPS54060	35
TPS2071	63	TPS2391	60	TPS3800	69	TPS5410	35
TPS2074	63	TPS2392	60	TPS3801	69	TPS54140	35
TPS2075	63	TPS2393	60	TPS3802	69	TPS54160	35
TPS2080/1/2	66	TPS2393A	60	TPS3803	5, 69	TPS5420	35
TPS2085/6/7	66	TPS2398	60	TPS3805	69	TPS54218	35
TPS2090/1/2	66	TPS2399	60	TPS3806	69	TPS54225	35
TPS2095/6/7	66	TPS2400	60	TPS3807	69	TPS54226	35
TPS2100/1	64	TPS2410/1	60	TPS3808	5, 6, 10, 69	TPS54231/2/3	35

Device Index (Continued)

Device	Page	Device	Page	Device	Page	Device	Page
TPS54283/6	35	TPS61042/3/5	37	TPS62351/2/3/4/5	36	TPS715xx	6, 28
TPS54290/1/2	35	TPS61043	44	TPS62400	36	TPS717xx	28
TPS5430	35, 37	TPS61045	44	TPS62401/2	36	TPS718xx	29
TPS54310/1/2/3/4/5/6	35	TPS61050/2	44	TPS62410	36	TPS719xx	29
TPS54317	35	TPS61054/55	44	TPS62420	36	TPS720xx	27, 28
TPS54318	35	TPS61058/9	44	TPS62510	36	TPS72118	5, 7
TPS54325	35	TPS61060	34, 44	TPS62560/1	36	TPS723xx	29
TPS54326	35	TPS61061	44	TPS62562	36	TPS725xx	28
TPS54331	35	TPS61062	44	TPS62590	36	TPS727xx	28
TPS54332	35	TPS61070/1/2/3	37	TPS62620/1/2/4	36	TPS728xx	28
TPS54350/2/3/4/5/6/7	35	TPS61080	37, 44	TPS62650	36	TPS730xx	28
TPS54372	11, 35	TPS61080/1	44	TPS62700	36	TPS731xx	5, 28
TPS54383/6	35	TPS61081	37, 43	TPS62750	36	TPS732xx	28
TPS54418	35	TPS61085	47, 48	TPS63000	36, 37	TPS734xx	28
TPS5450	35	TPS61087	47, 48	TPS63000/1/2	37	TPS735xx	28
TPS54610/1/2/3/4/5/6	35	TPS61090	37	TPS63001/2	36	TPS736xx	28
TPS54617	35	TPS61091/2	37	TPS63010/11/12	37	TPS737xx	28
TPS54620	8, 9, 35	TPS61093	37	TPS63030	6, 37	TPS742xx	27, 28
TPS54672	11, 35	TPS61097	6, 34	TPS63030/31	37	TPS743xx	9, 27, 28
TPS54872	11	TPS61097-33	37	TPS63700	37	TPS744xx	9, 10, 27, 29
TPS54910	35	TPS61100	37	TPS64200/1/2/3	32	TPS747xx	27, 28
TPS54972	11, 35	TPS61103/6/7	37	TPS65000/1	41	TPS748xx	8, 27, 28
TPS55383/6	35	TPS61120	37	TPS65010/1/2/3/4	41	TPS749xx	27, 29
TPS60100	39	TPS61121/2	37	TPS65020/1/2	41	TPS75003	41
TPS60101	39	TPS61130	37	TPS65023	7, 41	TPS75103/5	44
TPS60110	39	TPS61131/2	37	TPS650240/1/2/3/4/5	41	TPS752xx	29
TPS60111	39	TPS61140	44	TPS650250	41	TPS756xx	29
TPS60120/1	39	TPS61150A	44	TPS65050/1/2/4/6	41	TPS758xx	29
TPS60122/3	39	TPS61160	44	TPS65053/8	5, 41	TPS759xx	29
TPS60124/5	39	TPS61160A	44	TPS65070/3	7, 40, 41	TPS767D3xx	29
TPS60130/1	39	TPS61161	44	TPS65100	47, 48	TPS767xx	28
TPS60132/3	39	TPS61161A	44	TPS65101	47, 48	TPS768xx	28
TPS60140/1	39	TPS61165	44	TPS65105	47, 48	TPS769xx	28
TPS60150	39	TPS61166	44	TPS65140	47, 48	TPS773xx	28
TPS60200/1	39	TPS61170	37, 43	TPS65141	47, 48	TPS775xx	28
TPS60202/3	39	TPS61175	33, 37	TPS65145	47, 48	TPS776xx	28
TPS60204/5	39	TPS61180/1/2	44	TPS65146	48	TPS777xx	28
TPS60210/1	39	TPS61200	37	TPS65150	47, 48	TPS780xx	6, 28
TPS60212/3	39	TPS61201/2	37	TPS65160/A	47	TPS781xx	6, 7, 28
TPS60230/1	39, 44	TPS61220	6, 37	TPS65161	47	TPS782xx	6, 28
TPS60240	39	TPS61221/2	37	TPS65161A	47	TPS786xx	28
TPS60241	39	TPS61240	37	TPS65161B	47	TPS789xx	28
TPS60242	39	TPS61241	37	TPS65162	47	TPS792xx	28
TPS60243	39	TPS61500	43, 44	TPS65163	47	TPS794xx	28
TPS60250/5	44	TPS62040	36	TPS65165	47	TPS795xx	28
TPS60251	43, 44	TPS62042/3/4/6	36	TPS65166	47	TPS796xx	5, 28
TPS60300/2	39	TPS62050/1	36	TPS65167	47	TPS797xx	6, 28
TPS60301/3	39	TPS62052/4/6	36	TPS65167A	47	TPS799xx	28
TPS60310/2	39	TPS62060	36	TPS65200	41	TPS7A45	28
TPS60311/3	39	TPS62065	36	TPS65230/1	41	TSM104W/A	71
TPS60400	39	TPS62110	9, 36	TPS65232	41	UA723	30
TPS60401	39	TPS62111/2/3	36	TPS65510	41	UA78Lxx/A	30
TPS60402	39	TPS62200	36	TPS65520	41	UA78Mxx	30
TPS60403	39	TPS62201/2/3/4	36	TPS65530	41	UA78xx	30
TPS60500	39	TPS62205/7/8	36	TPS65552A	49	UA79Mxx	30
TPS60501	39	TPS62220	36	TPS65560	49	UA79xx	30
TPS60502	39	TPS62221/2/3/4/5	36	TPS65561	49	UC28023	20, 21
TPS60503	39	TPS62228/9	36	TPS65562	49	UC28025	20, 21
TPS61000	37	TPS62230	6, 36	TPS65563A	49	UC3524A	20, 21
TPS61001/2/3	37	TPS62230/1/2/3/4/8/9	36	TPS65573	49	UC3525B	20, 21
TPS61004/5/6	37	TPS62237	6	TPS65705	41	UC3572	32
TPS61010	37	TPS62240	5, 36	TPS65720/1	41	UC3714	23
TPS61011/2/3	37	TPS62242/3	36	TPS658600/10/20	41	UC3715	23
TPS61014/5/6	37	TPS62250	36	TPS65920	41	UC3823	20, 21
TPS61020	37	TPS62260	36	TPS65930	41	UC3823A/B	20, 21
TPS61024/5/7	37	TPS62261/2	36	TPS65950	40, 41	UC3824	20, 21
TPS61026/9	37	TPS62270	6, 36	TPS701xx	29	UC3825	20, 21
TPS61028	37	TPS62270/2/3	36	TPS703xx	29	UC3825A/B	20, 21
TPS61030	37	TPS62290	36	TPS707xx	29	UC3827-1/-2	20, 21
TPS61031/2	37	TPS62291/3	36	TPS712xx	29	UC3842A/3A/4A/5A	20, 21
TPS61040	37, 44	TPS62320	36	TPS713xx	29	UC3846/56	20, 21
TPS61041	37, 44	TPS62321	36	TPS714xx	6, 28	UC385-x	29
TPS61042	37, 44	TPS62350	36	TPS715Axx	6, 9, 28	UC3852	16

Device Index (Continued)



Device	Page	Device	Page	Device	Page	Device	Page
UC3853/A	16	UCC28060	15, 16	UCC37321	23	UCC3919	60
UC3854	16	UCC28061	15, 16	UCC37322	23	UCCx946	69
UC3854A/B	16	UCC28070	15, 16	UCC3800/1/2/3/4/5	20, 21	UCD7100	14
UC3855A/B	16	UCC28089	20, 21	UCC38050/1	16	UCD7100PWP	23
UC3875/6/7	20, 21	UCC28220/1	20, 21	UCC3806	20, 21	UCD7201	14
UC3879	20, 21	UCC28230/1	20, 21	UCC3807-1-2-3	20, 21	UCD7201PWP	23
UC3909	51	UCC28510/1/2/3	16	UCC3808-1/-2/A-1/A-2	20, 21	UCD7230	9, 14, 23
UC39431	70, 71	UCC28514/5/6/7	16	UCC38083/4/5/6	20, 21	UCD7231	14
UC39432/B	70, 71	UCC28521/8	16	UCC3809-1-2	20, 21	UCD7242	14
UCC25600	17, 19-21, 42	UCC28600	20, 21	UCC3810	20, 21	UCD74206	14
UCC27200	22, 23	UCC28610	20, 21	UCC3813-0/1/2/3/4/5	20, 21	UCD90120	68, 69
UCC27201	22, 23	UCC28810EVM-001	42	UCC3817A/8A	16	UCD90124	68, 69
UCC27221	23	UCC28810EVM-002	42	UCC3819A	16	UCD9060	69
UCC27222	23	UCC28810EVM-003	42	UCC384-x	29	UCD9081	69
UCC27223	23	UCC2891/3	20, 21	UCC38500/1/2/3	16	UCD9220	14
UCC27323	23	UCC2892/4	20, 21	UCC3884	20, 21	UCD9240	9, 14
UCC27324	23	UCC2897A	20, 21	UCC3888/89	20, 21		
UCC27325	23	UCC3526A	20, 21	UCC3895	20, 21		
UCC27423	23	UCC35701/2	20, 21	UCC38C40/1/2/3/4/5	20, 21		
UCC27424	23	UCC35705/6	20, 21	UCC3912	60		
UCC27425	23	UCC3580-1/-2/-3/-4	20, 21	UCC3915	60		
UCC28019A	16	UCC3583	20, 21	UCC3918	60		

Automotive Qualified Devices

Device	Page	Device	Page	Device	Page	Device	Page
bq24030	51	TPS3803	69	TPS5450	35	TPS732xx	28
bq24031	51	TPS3808	69	TPS54610/1/2/3/4/5/6	35	TPS737xx	28
bq24105	51	TPS3809	69	TPS60400	39	TPS752xx	29
REF50xx/A	71	TPS3813	69	TPS60401	39	TPS767D3xx	29
REG71055	39	TPS3820/8-xx	69	TPS60402	39	TPS767xx	28
TL1431	71	TPS3823	69	TPS60403	39	TPS768xx	28
TL1451A	32	TPS3824-xx	69	TPS61029	37	TPS769xx	28
TL431/A/B	71	TPS3825-xx	69	TPS61040	37, 44	TPS775xx	28
TL432/A/B	71	TPS3836/8	69	TPS61041	44	TPS776xx	28
TL5001	32	TPS3837	69	TPS61161	44	TPS797xx	28
TLC5916	46	TPS40090	32	TPS62000	36	TPS799xx	28
TLC5917	46	TPS40200	31	TPS62004/5/6/7/8	36	UA78Mxx	30
TLC5926	46	TPS40210/1	32	TPS62260	36	UCC27200	23
TLC5927	46	TPS51200	32	TPS63000	36, 37	UCC27201	23
TLC5941	46	TPS5130	32	TPS65023	41	UCC27423	23
TLC77xx	69	TPS5410	35	TPS65024/1/3	41	UCC27424	23
TLV431/A/B	71	TPS54140	35	TPS65100	47, 48	UCC27425	23
TLVH431/A/B	71	TPS54160	35	TPS65140	47, 48	UCC28220/1	21
TPS2829	23	TPS5420	35	TPS65145	47, 48		
TPS3306-xx	69	TPS54310/1/2/3/4/5/6	35	TPS701xx	29		
TPS3307-xx	69	TPS54372	35	TPS715xx	28		

HiRel Devices

Device	Page	Device	Page	Device	Page	Device	Page
LT1009	71	TPS3619	69	TPS5450	35	TPS768xx	28
REF32xx	71	TPS3803	69	TPS54610/3/5	35	TPS769xx	28
TL1431	71	TPS3805	69	TPS62000	36	TPS775xx	28
TL1451A	32	TPS3808	69	TPS62110/1/2/3	36	TPS776xx	28
TL431/A/B	71	TPS3809	69	TPS703xx	29	TPS797xx	28
TL494	21	TPS3813	69	TPS707xx	29	UA79xx	30
TL5001	32	TPS3836	69	TPS712xx	29	UC3524A	21
TL598	21	TPS3837	69	TPS715xx	28	UC3525B	21
TL7770-xx	69	TPS40055	31	TPS731xx	28	UC3825	21
TL77xx	69	TPS40200	31	TPS732xx	28	UC3842	21
TLC77xx	69	TPS5410	35	TPS736xx	28	UC3846	21
TPS2818	23	TPS5420	35	TPS75003	41	UCC27424	23
TPS2819	23	TPS5430	37	TPS752xx	29	UCC3806	21
TPS3106	69	TPS54310/1/2/3/4/5/6	35	TPS767D3xx	29		
TPS3307-xx	69	TPS54350/4/6	35	TPS767xx	28		

→ TI Worldwide Technical Support

Internet

TI Semiconductor Product Information Center Home Page

support.ti.com

TI Semiconductor KnowledgeBase Home Page

support.ti.com/sc/knowledgebase

Product Information Centers

Americas Phone +1(972) 644-5580

Brazil Phone 0800-891-2616

Mexico Phone 0800-670-7544

Fax +1(972) 927-6377

Internet/Email support.ti.com/sc/pic/americas.htm

Europe, Middle East, and Africa

Phone

European Free Call 00800-ASK-TEXAS
(00800 275 83927)

International +49 (0) 8161 80 2121

Russian Support +7 (4) 95 98 10 701

Note: The European Free Call (Toll Free) number is not active in all countries. If you have technical difficulty calling the free call number, please use the international number above.

Fax +(49) (0) 8161 80 2045

Internet support.ti.com/sc/pic/euro.htm

Japan

Fax International +81-3-3344-5317

Domestic 0120-81-0036

Internet/Email International support.ti.com/sc/pic/japan.htm

Domestic www.tij.co.jp/pic

Asia

Phone

International +91-80-41381665

Domestic Toll-Free Number

Australia 1-800-999-084

China 800-820-8682

Hong Kong 800-96-5941

India 1-800-425-7888

Indonesia 001-803-8861-1006

Korea 080-551-2804

Malaysia 1-800-80-3973

New Zealand 0800-446-934

Philippines 1-800-765-7404

Singapore 800-886-1028

Taiwan 0800-006800

Thailand 001-800-886-0010

Fax +886-2-2378-6808

Email tiasia@ti.com or ti-china@ti.com

Internet support.ti.com/sc/pic/asia.htm

Safe Harbor Statement: This publication may contain forward-looking statements that involve a number of risks and uncertainties. These "forward-looking statements" are intended to qualify for the safe harbor from liability established by the Private Securities Litigation Reform Act of 1995. These forward-looking statements generally can be identified by phrases such as TI or its management "believes," "expects," "anticipates," "foresees," "forecasts," "estimates" or other words or phrases of similar import. Similarly, such statements herein that describe the company's products, business strategy, outlook, objectives, plans, intentions or goals also are forward-looking statements. All such forward-looking statements are subject to certain risks and uncertainties that could cause actual results to differ materially from those in forward-looking statements. Please refer to TI's most recent Form 10-K for more information on the risks and uncertainties that could materially affect future results of operations. We disclaim any intention or obligation to update any forward-looking statements as a result of developments occurring after the date of this publication.

E093008

Important Notice: The products and services of Texas Instruments Incorporated and its subsidiaries described herein are sold subject to TI's standard terms and conditions of sale. Customers are advised to obtain the most current and complete information about TI products and services before placing orders. TI assumes no liability for applications assistance, customer's applications or product designs, software performance, or infringement of patents. The publication of information regarding any other company's products or services does not constitute TI's approval, warranty or endorsement thereof.

Trademarks: The platform bar, Analog eLab, AutoComp, Auto-Track, C2000, DaVinci, EasyScale, FilterPro, Fusion Digital Power, Impedance Track, Natural Interleaving, NexFET, OMAP, OpAmpPro, POLA, PowerPAD, Predictive Gate Drive, SmartReflex, SWIFT, SwitcherPro, TINA-TI, TMS320C2000, TPS40K, *TurboTrans* and TrueDrive are trademarks of Texas Instruments. AdvancedMC is a trademark of PCI Industrial Computer Manufacturers Group. ARM7 is a trademark of ARM Limited. CableCARD is a trademark of Cable Labs. ExpressCard is a trademark of the Personal Computer Memory Card International Association (PCMCIA). Freescale is a trademark of Freescale Semiconductor. Intel XScale and Intel Atom are trademarks of Intel Corporation. Marvell is a trademark of Marvell Technology Group Ltd. PMBus is a trademark of System Management Interface Forum, Inc. RMI is a trademark of RMI Corporation. Samsung is a trademark of Samsung. Stellaris is a trademark of Luminary Micro, an acquisition of Texas Instruments. Stratix is a trademark and Altera is a registered trademark of Altera Corporation. Spartan is a trademark and Virtex and Xilinx are registered trademarks of Xilinx, Inc. Windows is a registered trademark of Microsoft Corporation. All other trademarks are the property of their respective owners.

© 2009 Texas Instruments Incorporated
Printed in U.S.A. by (Printer, City, State)



FSC logo to be inserted by FSC-certified printer.



Find Products Fast!

www.ti.com/analoglit

Product Guides:

- Amplifier and Data Converter
- Analog Switch
- Clocks and Timing
- Embedded Processing
- Interface
- Logic
- Low-Power RF
- Power Management



Reference Design Cookbooks for Power Management Products

TI introduced its first “cookbook” of power management reference designs in 3Q 2005 and the newest edition, *LED Reference Design Cookbook*, released late 2009. In these guides, you will find many complete reference designs with tables, schematics and waveforms. A few of the designs included are:

- Synchronous Buck Converter
- Green-Mode AC Input Flyback
- Multi-Channel Buck for DDR
- Synchronous Battery-Pack Charger
- Non-Isolated Non-Synchronous SEPIC
- Battery Charger Front-End Protection Circuit
- Small LCD Backlight with Digital and PWM Dimming
- Wireless-Controlled Triple LED Drive

These cookbooks and other reference designs are available online at:

www.ti.com/powerreferencedesigns



**Connect with your Power-
Management peers and
customers to ask questions,
share knowledge, explore
ideas, and solve problems.**

Join the discussion today!

www.ti.com/e2epower



TI E2E Community

**engineer.to.engineer,
solving problems**



14950 F.A.A. Blvd.
Fort Worth, Texas 76155

Address service requested

PRSR STD
U.S. POSTAGE
PAID
DALLAS, TEXAS
PERMIT NO. 2758

IMPORTANT NOTICE

Texas Instruments Incorporated and its subsidiaries (TI) reserve the right to make corrections, modifications, enhancements, improvements, and other changes to its products and services at any time and to discontinue any product or service without notice. Customers should obtain the latest relevant information before placing orders and should verify that such information is current and complete. All products are sold subject to TI's terms and conditions of sale supplied at the time of order acknowledgment.

TI warrants performance of its hardware products to the specifications applicable at the time of sale in accordance with TI's standard warranty. Testing and other quality control techniques are used to the extent TI deems necessary to support this warranty. Except where mandated by government requirements, testing of all parameters of each product is not necessarily performed.

TI assumes no liability for applications assistance or customer product design. Customers are responsible for their products and applications using TI components. To minimize the risks associated with customer products and applications, customers should provide adequate design and operating safeguards.

TI does not warrant or represent that any license, either express or implied, is granted under any TI patent right, copyright, mask work right, or other TI intellectual property right relating to any combination, machine, or process in which TI products or services are used. Information published by TI regarding third-party products or services does not constitute a license from TI to use such products or services or a warranty or endorsement thereof. Use of such information may require a license from a third party under the patents or other intellectual property of the third party, or a license from TI under the patents or other intellectual property of TI.

Reproduction of TI information in TI data books or data sheets is permissible only if reproduction is without alteration and is accompanied by all associated warranties, conditions, limitations, and notices. Reproduction of this information with alteration is an unfair and deceptive business practice. TI is not responsible or liable for such altered documentation. Information of third parties may be subject to additional restrictions.

Resale of TI products or services with statements different from or beyond the parameters stated by TI for that product or service voids all express and any implied warranties for the associated TI product or service and is an unfair and deceptive business practice. TI is not responsible or liable for any such statements.

TI products are not authorized for use in safety-critical applications (such as life support) where a failure of the TI product would reasonably be expected to cause severe personal injury or death, unless officers of the parties have executed an agreement specifically governing such use. Buyers represent that they have all necessary expertise in the safety and regulatory ramifications of their applications, and acknowledge and agree that they are solely responsible for all legal, regulatory and safety-related requirements concerning their products and any use of TI products in such safety-critical applications, notwithstanding any applications-related information or support that may be provided by TI. Further, Buyers must fully indemnify TI and its representatives against any damages arising out of the use of TI products in such safety-critical applications.

TI products are neither designed nor intended for use in military/aerospace applications or environments unless the TI products are specifically designated by TI as military-grade or "enhanced plastic." Only products designated by TI as military-grade meet military specifications. Buyers acknowledge and agree that any such use of TI products which TI has not designated as military-grade is solely at the Buyer's risk, and that they are solely responsible for compliance with all legal and regulatory requirements in connection with such use.

TI products are neither designed nor intended for use in automotive applications or environments unless the specific TI products are designated by TI as compliant with ISO/TS 16949 requirements. Buyers acknowledge and agree that, if they use any non-designated products in automotive applications, TI will not be responsible for any failure to meet such requirements.

Following are URLs where you can obtain information on other Texas Instruments products and application solutions:

Products

Amplifiers	amplifier.ti.com
Data Converters	dataconverter.ti.com
DLP® Products	www.dlp.com
DSP	dsp.ti.com
Clocks and Timers	www.ti.com/clocks
Interface	interface.ti.com
Logic	logic.ti.com
Power Mgmt	power.ti.com
Microcontrollers	microcontroller.ti.com
RFID	www.ti-rfid.com
RF/IF and ZigBee® Solutions	www.ti.com/lprf

Applications

Audio	www.ti.com/audio
Automotive	www.ti.com/automotive
Broadband	www.ti.com/broadband
Digital Control	www.ti.com/digitalcontrol
Medical	www.ti.com/medical
Military	www.ti.com/military
Optical Networking	www.ti.com/opticalnetwork
Security	www.ti.com/security
Telephony	www.ti.com/telephony
Video & Imaging	www.ti.com/video
Wireless	www.ti.com/wireless

Mailing Address: Texas Instruments, Post Office Box 655303, Dallas, Texas 75265
Copyright © 2009, Texas Instruments Incorporated