

DATA SHEET

RM14/I RM cores and accessories

Product specification
Supersedes data of January 1999
File under Ferrite Ceramics, MA01

2000 Apr 20

RM cores and accessories

RM14/I

CORE SETS

Effective core parameters

SYMBOL	PARAMETER	VALUE	UNIT
$\Sigma(I/A)$	core factor (C1)	0.353	mm ⁻¹
V_e	effective volume	13900	mm ³
l_e	effective length	70.0	mm
A_e	effective area	198	mm ²
A_{min}	minimum area	168	mm ²
m	mass of set	≈74	g

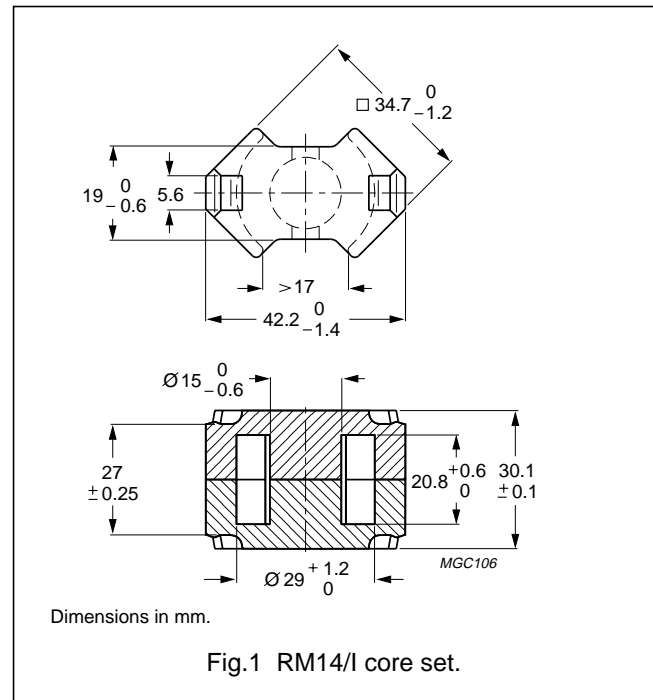

Core sets for general purpose transformers and power applications

Clamping force for A_L measurements, 80 ±20 N.

GRADE	A_L (nH)	μ_e	AIR GAP (μ m)	TYPE NUMBER
3C90	250 ±3%	≈70	≈950	RM14/I-3C90-A250
	315 ±3%	≈88	≈700	RM14/I-3C90-A315
	400 ±3%	112	≈550	RM14/I-3C90-A400
	630 ±5%	≈177	≈250	RM14/I-3C90-A630
	1000 ±5%	≈281	≈150	RM14/I-3C90-A1000
	7100 ±25%	≈1990	≈0	RM14/I-3C90
3C94 <small>des</small>	250 ±3%	≈70	≈950	RM14/I-3C94-A250
	315 ±3%	≈88	≈700	RM14/I-3C94-A315
	400 ±3%	112	≈550	RM14/I-3C94-A400
	630 ±5%	≈177	≈250	RM14/I-3C94-A630
	1000 ±5%	≈281	≈150	RM14/I-3C94-A1000
	7100 ±25%	≈1990	≈0	RM14/I-3C94
3C96 <small>prot</small>	6200 ±25%	≈1740	≈0	RM14/I-3C96
3F3	250 ±3%	≈70	≈950	RM14/I-3F3-A250
	315 ±3%	≈88	≈700	RM14/I-3F3-A315
	400 ±3%	112	≈550	RM14/I-3F3-A400
	630 ±5%	≈177	≈250	RM14/I-3F3-A630
	1000 ±5%	≈281	≈150	RM14/I-3F3-A1000
	5700 ±25%	≈1600	≈0	RM14/I-3F3

RM cores and accessories

RM14/I

Properties of core sets under power conditions

GRADE	B (mT) at	CORE LOSS (W) at			
	H = 250 A/m; f = 25 kHz; T = 100 °C	f = 25 kHz; \hat{B} = 200 mT; T = 100 °C	f = 100 kHz; \hat{B} = 100 mT; T = 100 °C	f = 100 kHz; \hat{B} = 200 mT; T = 100 °C	f = 400 kHz; \hat{B} = 50 mT; T = 100 °C
3C90	≥315	≤1.67	≤1.76	–	–
3C94	≥315	–	≤1.55	≈6.0	≈3.5
3C96	≥315	–	≈1.2	≈4.5	≈2.5
3F3	≥315	–	≤1.55	–	≤2.65

RM cores and accessories

RM14/I

COIL FORMERS

General data

PARAMETER	SPECIFICATION
Coil former material	phenolformaldehyde (PF), glass reinforced, flame retardant in accordance with "UL 94V-0"; UL file number E167521(M)
Pin material	copper-tin alloy (CuSn), tin-lead alloy (SnPb) plated
Maximum operating temperature	180 °C, "IEC 60085", class H
Resistance to soldering heat	"IEC 60068-2-20", Part 2, Test Tb, method 1B, 350 °C, 3.5 s
Solderability	"IEC 60068-2-20", Part 2, Test Ta, method 1

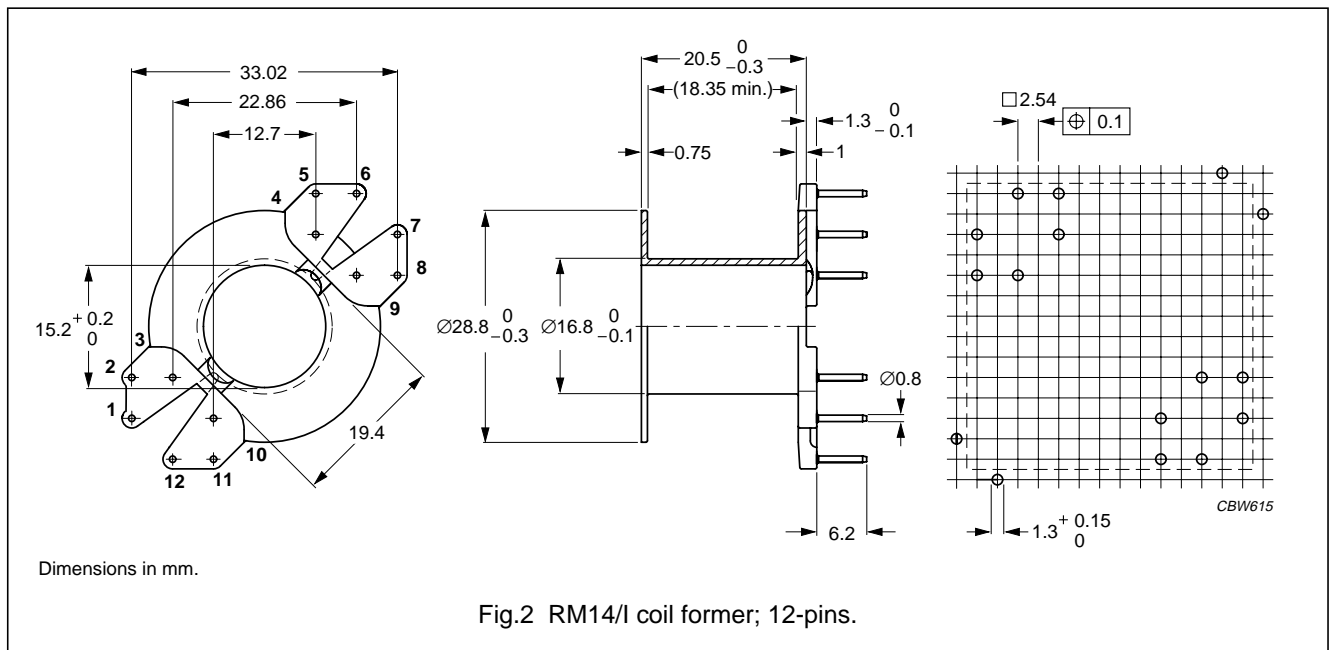

Winding data for 12-pins RM14/I coil former

NUMBER OF SECTIONS	NUMBER OF PINS	PIN POSITIONS USED	AVERAGE LENGTH OF TURN (mm)	WINDING AREA (mm ²)	WINDING WIDTH (mm)	TYPE NUMBER
1	10	1, 2, 3, 4, 6, 7, 9, 10, 11, 12	71	112	18.4	CSV-RM14-1S-10P
1	12	all	71	112	18.4	CSV-RM14-1S-12P

RM cores and accessories

RM14/I

General data

PARAMETER	SPECIFICATION
Coil former material	polybutyleneterephthalate (PBT), glass-reinforced, flame retardant in accordance with "UL 94V-0"; UL file number E45329(R)
Pin material	copper-tin alloy (CuSn), tin-lead alloy (SnPb) plated
Maximum operating temperature	155 °C, "IEC 60085", class F
Resistance to soldering heat	"IEC 60068-2-20", Part 2, Test Tb, method 1B, 350 °C, 3.5 s
Solderability	"IEC 60068-2-20", Part 2, Test Ta, method 1

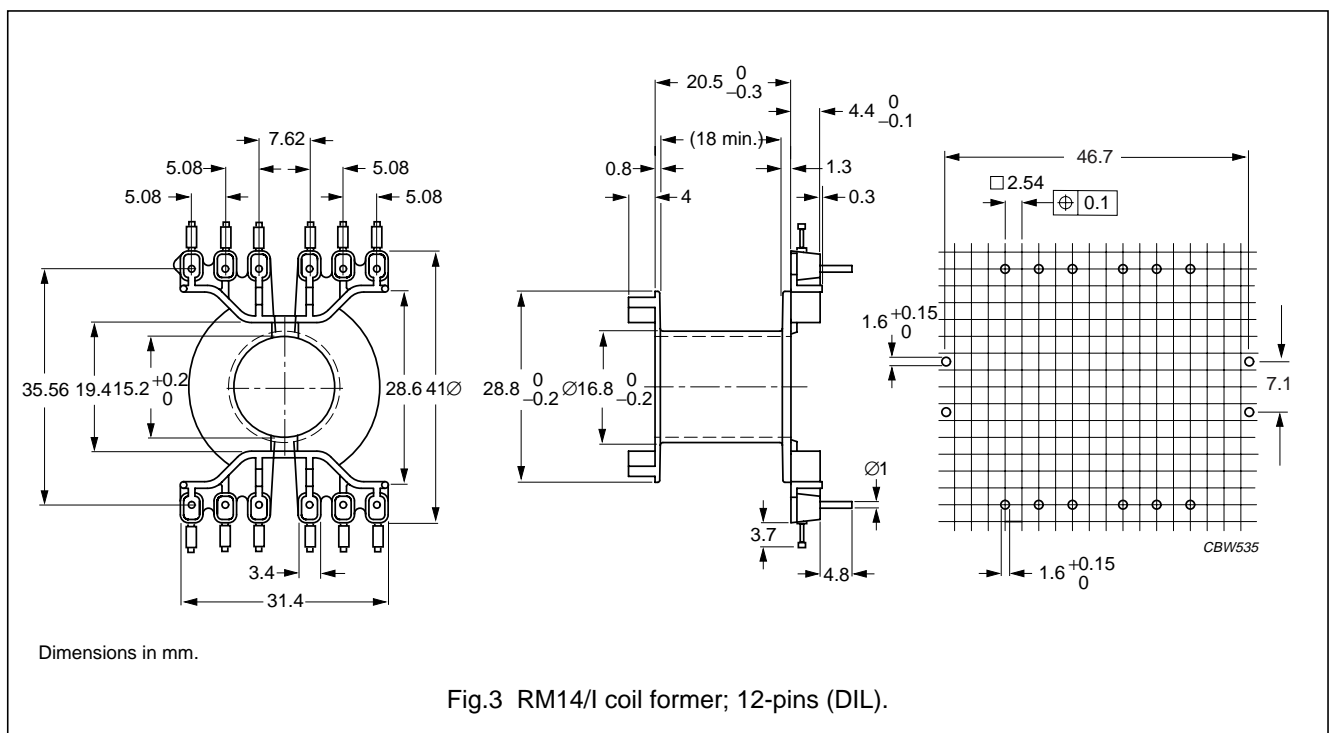

Winding data for 12-pins RM14/I coil former (DIL)

NUMBER OF SECTIONS	AVERAGE LENGTH OF TURN (mm)	WINDING AREA (mm ²)	WINDING WIDTH (mm)	TYPE NUMBER
1	71	111	18.0	CPV-RM14/I-1S-12PD

RM cores and accessories

RM14/I

MOUNTING PARTS

General data mounting clip with earth pin

ITEM	SPECIFICATION
Clamping force	≈40 N
Clip material	stainless steel
Clip plating	tin-lead alloy (SnPb)
Solderability	"IEC 60068-2-20", Part 2, Test Ta, method 1
Type number	CLI/P-RM14/I

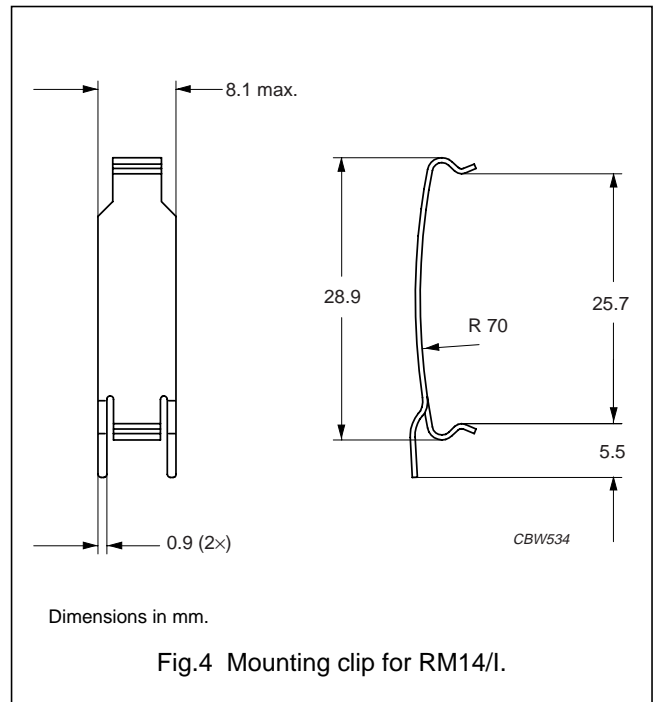

RM cores and accessories

RM14/I



DATA SHEET STATUS DEFINITIONS

DATA SHEET STATUS	PRODUCT STATUS	DEFINITIONS
Preliminary specification	Development	This data sheet contains preliminary data. Philips Components reserves the right to make changes at any time without notice in order to improve design and supply the best possible product.
Product specification	Production	This data sheet contains final specifications. Philips Components reserves the right to make changes at any time without notice in order to improve design and supply the best possible product.

DISCLAIMER

Life support applications — These products are not designed for use in life support appliances, devices, or systems where malfunction of these products can reasonably be expected to result in personal injury. Philips Components customers using or selling these products for use in such applications do so at their own risk and agree to fully indemnify Philips Components for any damages resulting from such application.

PRODUCT STATUS DEFINITIONS

STATUS	INDICATION	DEFINITION
Prototype		These are products that have been made as development samples for the purposes of technical evaluation only. The data for these types is provisional and is subject to change.
Design-in		These products are recommended for new designs.
Preferred		These products are recommended for use in current designs and are available via our sales channels.
Support		These products are not recommended for new designs and may not be available through all of our sales channels. Customers are advised to check for availability.