

Projet 4 - REMOTE / Télécommande 12 boutons avec module XBEE

Projet : IUT7
Info : [DIV670]
Révision : 1 du 9 février 2015

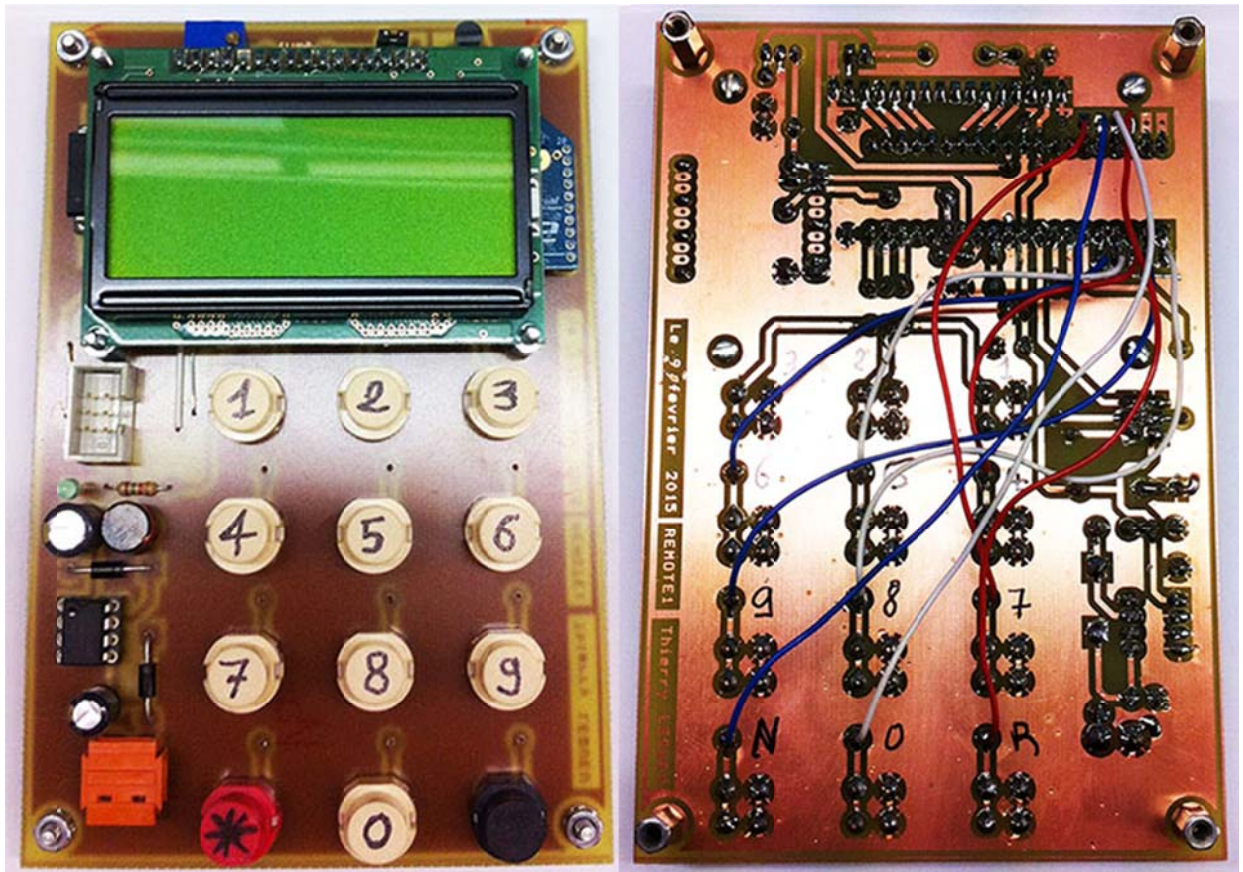

Figure 4.1. Vue de carte électronique (images-maquettes\REMOTE1-13 & 33.jpg).

4.1 Liste des documents

- Désignation des composants
- Prix du montage.
- Schéma électronique.
- Circuit imprimé coté cuivre.
- Circuit imprimé coté composants.
- Implantation des composants.
- Documentations des composants.

4.2 Désignation des composants

Tableau 4.1. Liste de composants (projets-iut6.xls / REMOTE1).

N°	Qu.	Référence	Désignation	Empreinte	Code Commande
1	1	AFF1	LCD 16x4	MC1604C	RS-449-1012
2	1	C1	100uF 25V FC	RADIAL08	Stock
3	1	C2	470uF 6.3V	RADIAL06L	Stock
4	1	C3	10uF 6.3V	RADIAL06	Stock
5	1	C4	100nF	CK06	
6	2	C5,C6	22pF	CK06	Stock
7	1	C7	22uF 25V FC	RADIAL05	
8	1	C8	330nF	CK07L	RS-686-9616
9	1	C9	100nF	CK05L	Stock
10	2	D1,D2	11DQ04	DO41	
11	1	D3	VERTE 3mm 2mA	LED03	
12	1	JP1	+9V	WEID2	
13	1	JP2	CON ISP6	06SH100L	
14	1	JP3	RETRO	02PL1	
15	1	L1	47uH	RADIAL06L	
16	1	P1	10K	RAJ1	
17	1	Q1	16 MHz	HC18UV	
18	1	R1	1.5k	RC04L	
19	2	R3,R2	10k	RC04L	
20	1	R4	18k	RC04L	
21	12	SW1...SW12	TOUCHE	REDROND	
22	1	U1	LM2574N-5.0	08DIP300L	
23	1	U2	ATmega8535	40DIP600L	
24	1	U3	XBEE PRO	XBEE	
25	1	U4	L78L33ACZ	TO92L	
26	4	VIS1...VIS4	VISSERIE	M3L	

4.3 Calculs des composants

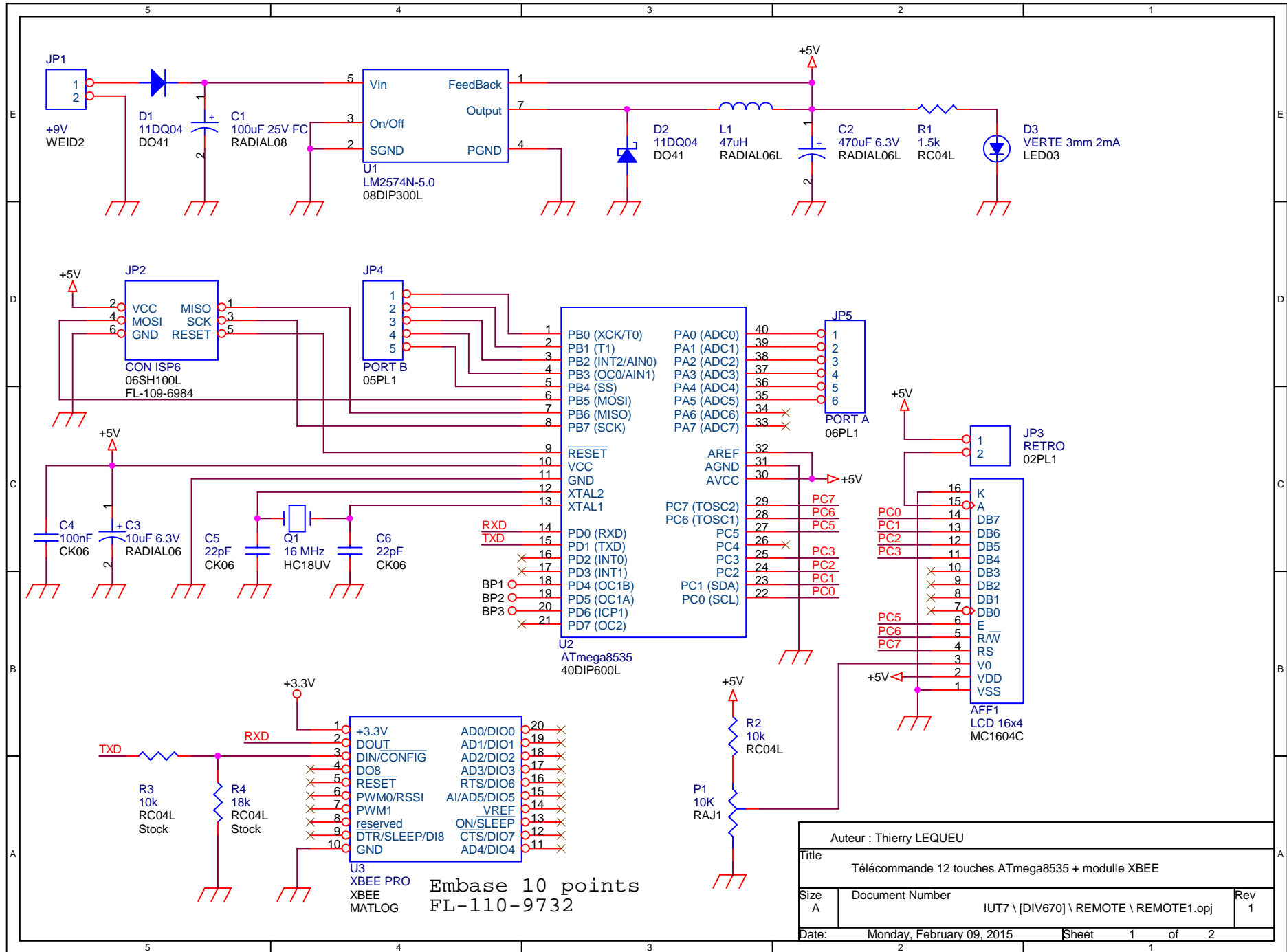

Auteur : Thierry LEQUEU		
Title Télécommande 12 touches ATmega8535 + module XBEE		
Size A	Document Number IUT7 \ [DIV670] \ REMOTE \ REMOTE1.opj	Rev 1
Date:	Monday, February 09, 2015	Sheet 1 of 2

Embase 10 points
FL-110-9732

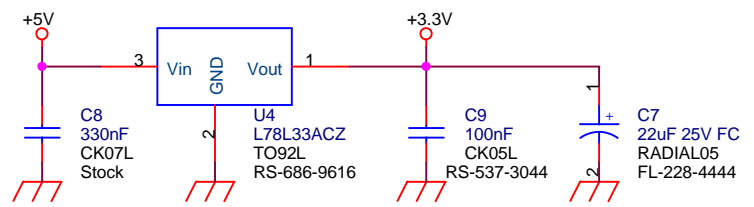
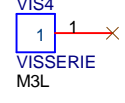
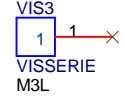
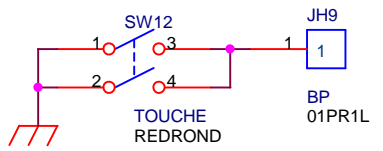
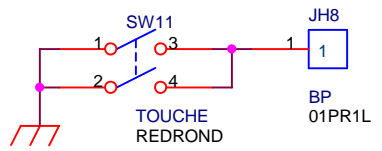
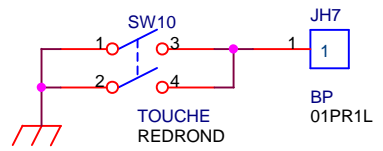
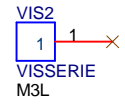
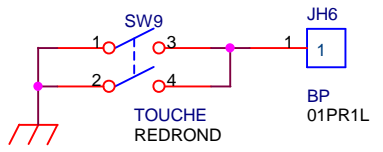
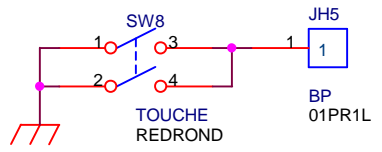
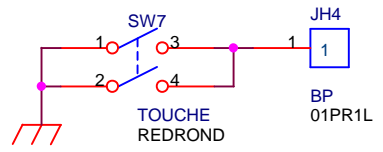
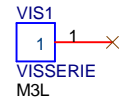
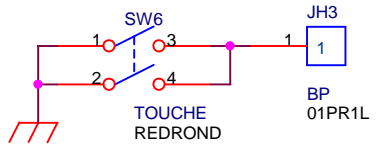
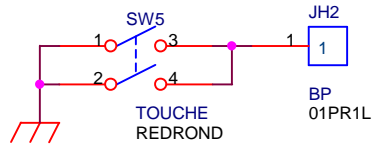
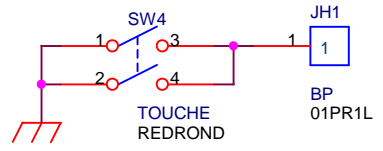
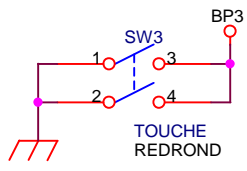
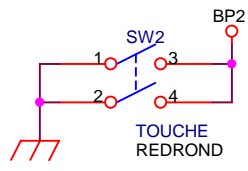
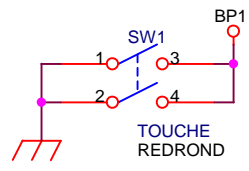

Auteur : Thierry LEQUEU		
Title Télécommande 12 touches ATmega8535 + module XBEE		
Size A	Document Number IUT7 \ [DIV670] \ REMOTE \ REMOTE1.opj	Rev 1
Date:	Monday, February 09, 2015	Sheet 2 of 2

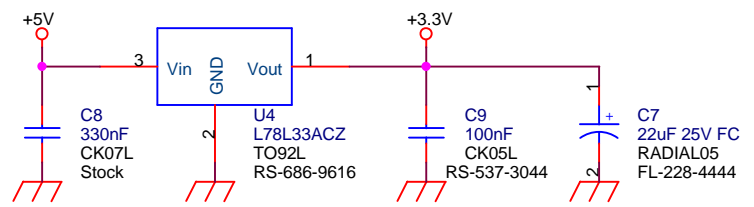
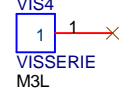
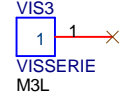
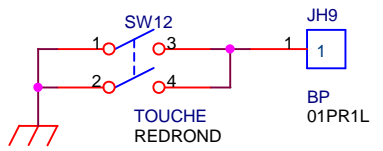
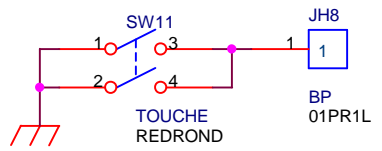
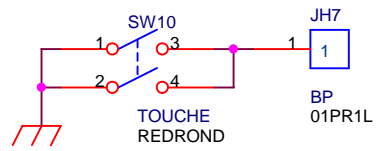
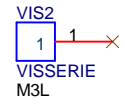
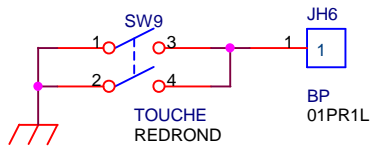
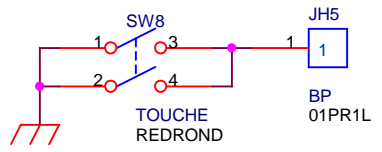
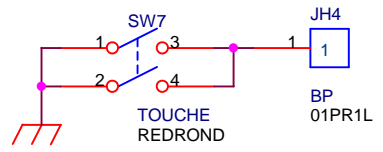
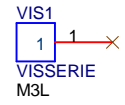
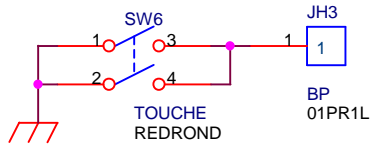
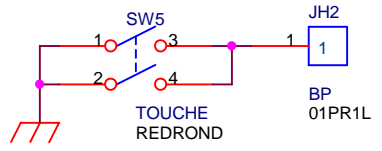
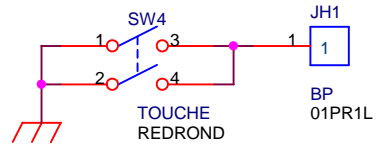
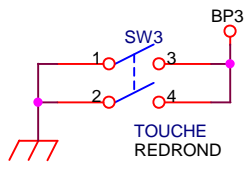
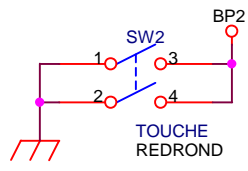
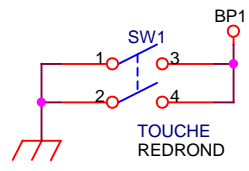

Auteur : Thierry LEQUEU		
Title Télécommande 12 touches ATmega8535 + module XBEE		
Size A	Document Number IUT7 \ [DIV670] \ REMOTE \ REMOTE1.opj	Rev 1
Date:	Monday, February 09, 2015	Sheet 2 of 2

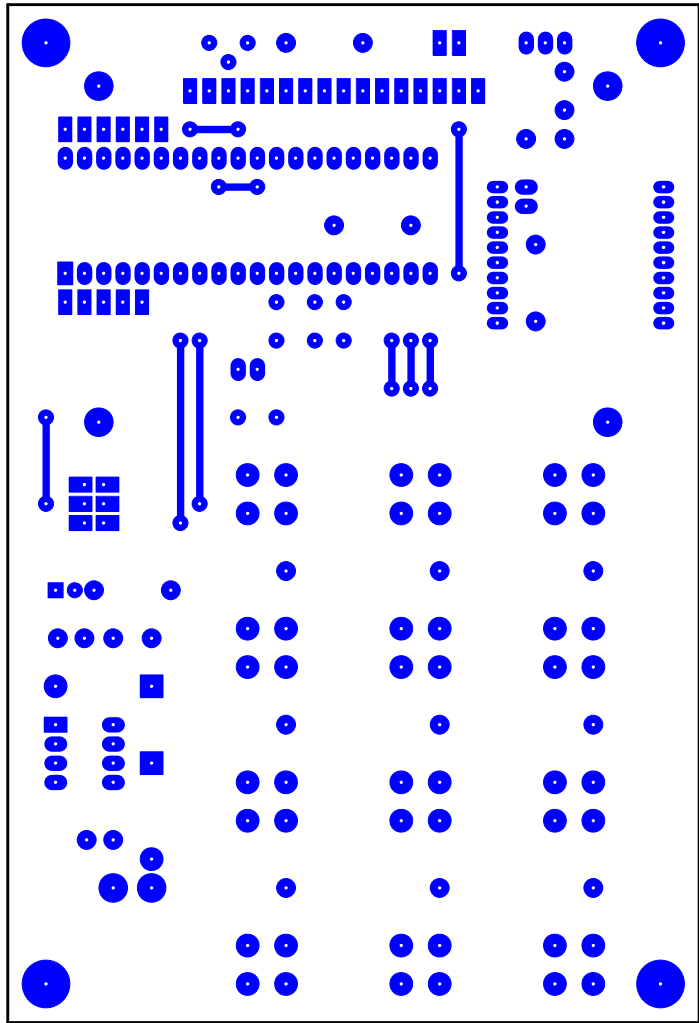

Face TOP

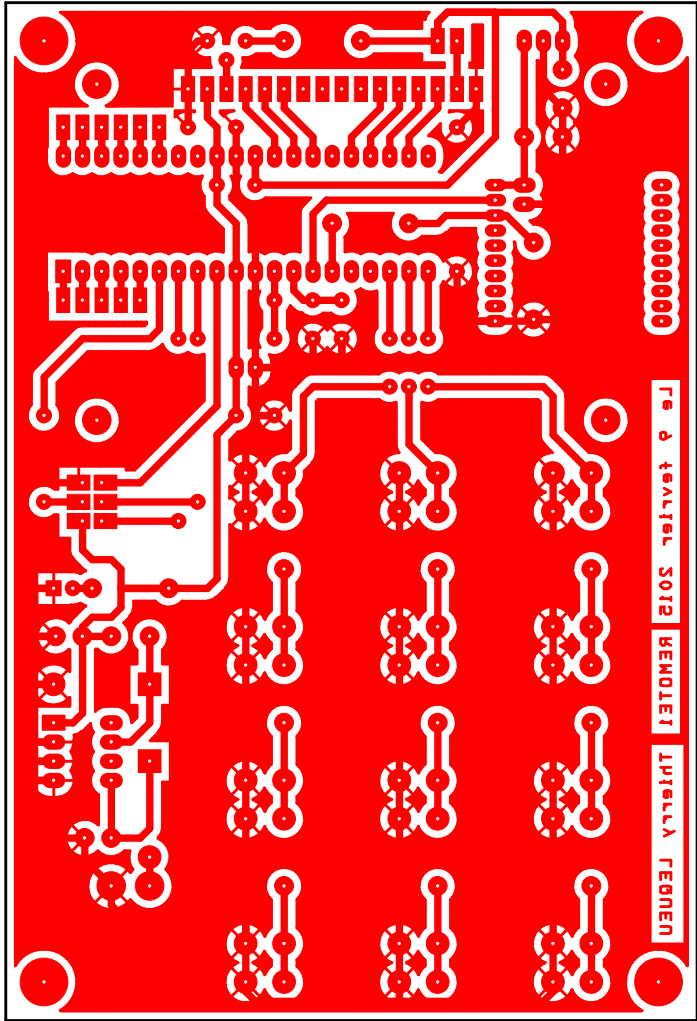

Face BOT

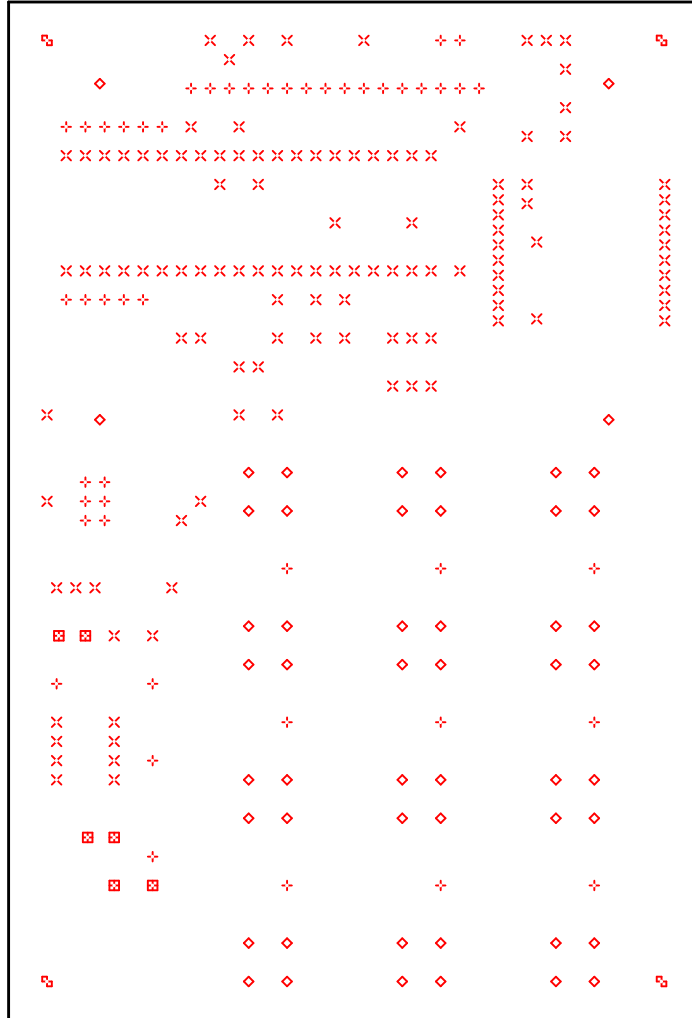

FACE DRD

DRILL CHART				
SYM	DIAM	TOL	QTY	NOTE
x	0.787 mm		120	
⊞	0.800 mm		4	
+	0.991 mm		48	
◇	1.194 mm		52	
⊞	1.499 mm		2	
⊞	3.200 mm		4	
TOTAL			230	