

### Retroreflective Models

- Sensing distance of 10 m, with polarized light to detect shiny objects.
- Operation stability monitored by the stability indicator.

### Distance-setting Models

- Distance-setting models with a long 2-m sensing distance incorporate a teaching function.
- Set sensing area (zone setting) function allows detection of shiny objects with uneven surface.

### Common Features

- Meets IEC IP67 requirements, thus resisting water.
- E3G has an M12 rotary connector which ensures easy maintenance.



## Ordering Information

### Sensors

MSR: Mirror Surface Reflection

: Red light

: Infrared light

Sensing method	Appearance	Connection method	Sensing distance	Timer function (see note 4)	Model	
					NPN/PNP selector (see note 2)	Relay output (see note 3)
Retroreflective (with MSR function)		Pre-wired	(see note 1) 10 m (500 mm)	---	E3G-R13	---
		Connector			E3G-R17	
		Terminal block			---	E3G-MR19 E3G-MR19T
Distance-setting		Pre-wired	White paper (300 x 300 mm) 0.2 to 2 m	---	E3G-L73	---
		Connector			E3G-L77	
		Terminal block			---	E3G-ML79 E3G-ML79T

- Note:**
1. Figures in parentheses indicate the minimum required distances between the Sensors and Reflectors.
  2. Specify the retroreflective model with or without Reflector by adding the suffix code to the model number as shown below. (e.g., E3G-R13-G)

Suffix code	E39-R2 Reflector (retroreflective model)
None	Provided
-G	Not provided (order separately)

3. Specify the conduit of the relay output model and Reflector by adding the suffix code to the model number as shown below. (e.g., E3G-MR19-G, E3G-ML79-US)

Suffix code	Conduit	E39-R2 Reflector (retroreflective model)
None	PF <sup>1</sup> / <sub>2</sub> (JIS)	Provided
-G	PG13.5 (CENELEC)	Not provided (order separately)
-US	<sup>1</sup> / <sub>2</sub> -14NPT	Provided

4. For ON- and OFF-delay timers, Td1 and Td2 are independently variable.

## Accessories (Order Separately)

### Reflectors

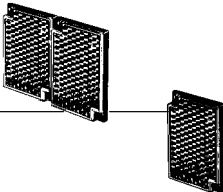

Shape	Sensing distance (typical)	Model	Minimum order	Remarks
	10 m (500 mm) (see note)	E39-R2	1	Provided with E3G-R□□, E3G-MR□□ and E3G-MR□□-US
	6 m (100 mm) (see note)	E39-R1	1	---

**Note:** Figures in parentheses indicate the minimum required distance between the Sensors and Reflectors.

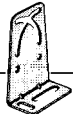

### Terminal Protection Cover for Side-pullout Cable

Shape	Model	Minimum order	Applicable model	Remarks
	E39-L129	1	E3G-MR19 (T), ML79 (T)	Provided with rubber bushing and cap for pullout prevention in vertical direction

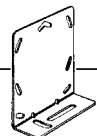
### Mounting Brackets

Shape	Model	Minimum order	Applicable model	Remarks
	E39-L131	1	E3G-R1□ E3G-L7□	---
	E39-L132	1		Rear-mounting use
	E39-L135	1	E3G-MR19 (T) E3G-ML79 (T)	Cable pulled out in the downward direction
	E39-L136	1		---

### Sensor I/O Connectors

Cord	Shape	Cable type		Model
Standard	Straight 	2 m	Three-wire type	XS2F-D421-DC0-A
		5 m		XS2F-D421-GC0-A
	L-shaped 	2 m		XS2F-D422-DC0-A
		5 m		XS2F-D422-GC0-A

**Note:** Refer to the *Sensor I/O Connectors Catalog (X065)* for details.

# Specifications

## ■ Ratings/Characteristics

Sensing method		Retroreflective (with MSR function)				Distance-setting			
Item	Model	E3G-R13	E3G-R17	E3G-MR19	E3G-MR19T	E3G-L73	E3G-L77	E3G-ML79	E3G-ML79T
Sensing distance		10 m (500 mm) <sup>*1</sup> (when using E39-R2)				White paper (300 x 300 mm): 0.2 to 2 m			
Setting distance		---				White paper (300 x 300 mm): 0.5 to 2 m			
Standard sensing object		Opaque: 80 dia. min.				---			
Hysteresis (typical)		---				10% of setting distance			
Directional angle		Sensor: 1° to 5° Reflector: 40° min.				---			
Reflectivity characteristics (black/white error)		---				±10% max. (at 1-m sensing distance)			
Light source (wavelength)		Red LED (700 nm)				Infrared LED (860 nm)			
Spot size		---				70 dia. max. (at 1-m sensing distance)			
Power supply voltage		10 to 30 VDC including 10% (p-p) ripple		12 to 240 VDC ± 10% including 10% (p-p) max. ripple 24 to 240 VAC ± 10% at 50/60 Hz		10 to 30 VDC including 10% (p-p) ripple		12 to 240 VDC ± 10% including 10% (p-p) max. ripple 24 to 240 VAC ± 10% at 50/60 Hz	
Current/Power consumption		50 mA max.		2 W max.		60 mA max.		2 W max.	
Control output		Load power supply voltage: 30 VDC max. Load current: 100 mA max. Residual voltage: NPN output: 1.2 V max. PNP output: 2.0 V max. Open collector output (NPN/PNP selectable) L.ON/D.ON selectable		Relay output: SPDT, 3 A (cos φ = 1) max. at 250 VAC or 3 A max. at 30 VDC L.ON/D.ON selectable		Load power supply voltage: 30 VDC max. Load current: 100 mA max. Residual voltage: NPN output: 1.2 V max. PNP output: 2.0 V max. Open collector output (NPN/PNP selectable) L.ON/D.ON selectable		Relay output: SPDT, 3 A (cos φ = 1) max. at 250 VAC or 3 A max. at 30 VDC L.ON/D.ON selectable	
Life expectancy (relay output)		Mechanical: 50,000,000 operations min. (switching frequency: 18,000 operations/h) Electrical: 100,000 operations min. (switching frequency: 1,800 operations/h)							
Circuit protection		Protection from reversed power supply connection, load short-circuit, and mutual interference		Protection from mutual interference		Protection from power supply reverse connection, load short-circuit, and mutual interference		Protection from mutual interference	
Response time		Operation or reset: 1 ms		Operation or reset: 30 ms max.		Operation or reset: 5 ms		Operation or reset: 30 ms max.	
Sensitivity adjustment		One-turn adjuster				Teaching (in NORMAL or ZONE mode)			
Ambient illumination (receiver side)		Incandescent lamp: 3,000 lx max. Sunlight: 10,000 lx max.							
Ambient temperature		Operating: -25°C to 55°C/Storage: -30°C to 70°C (with no icing nor condensation)							
Ambient humidity		Operating: 35% to 85%/Storage: 35% to 95% (with no condensation)							
Insulation resistance		20 MΩ min. at 500 VDC							
Dielectric strength		1,000 VAC, 50/60 Hz for 1 min		2,000 VAC, 50/60 Hz for 1 min		1,000 VAC, 50/60 Hz for 1 min		2,000 VAC, 50/60 Hz for 1 min	
Vibration resistance		Destruction: 10 to 55 Hz, 1.5-mm double amplitude for 2 hours each in X, Y, and Z directions							
Shock resistance		Destruction: 500 m/s <sup>2</sup> 3 times each in X, Y, and Z directions							
Degree of protection		IEC60529 IP67 (with protective cover)							
Connection method		Pre-wired (Standard length: 2 m)	M12 Connector	Terminal block		Pre-wired (standard length: 2 m)	M12 Connector	Terminal block	
Weight (packed state)		Approx. 150 g	Approx. 50 g	Approx. 150 g			Approx. 50 g	Approx. 150 g	
Material	Case	PBT (polybutylene terephthalate)							
	Lens	Acrylic (PMMA)							
	Mounting Bracket	Stainless steel (SUS304)							
Accessories	Reflector <sup>*2</sup> , instruction sheet, and screwdriver for adjustment <sup>*2</sup>					Instruction sheet and screwdriver for adjustment			

**Note:** \*1. Figures in parentheses indicate the minimum required distances between the Sensors and Reflectors.

\*2. These accessories are not provided with the retroreflective models with the suffix "-G."

# Engineering Data (Typical)

## ■ E3G-R/MR Retroreflective Models

### Parallel Movement (Typical)

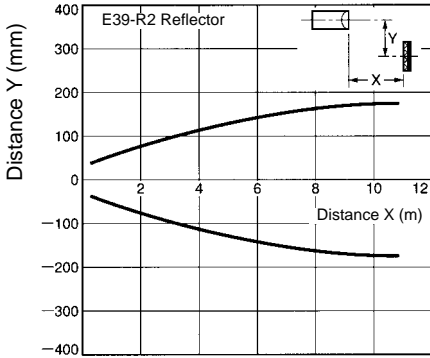

### Incident Output vs. Distance

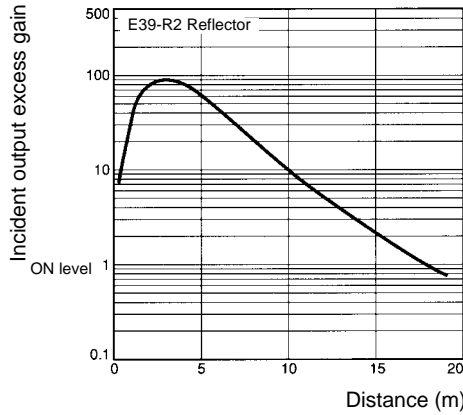

## ■ E3G-L/ML Distance-setting Models

### Spot Diameter vs. Sensing Distance

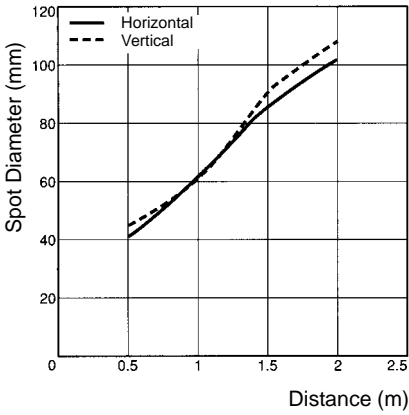

### Sensing Zone in NORMAL Mode

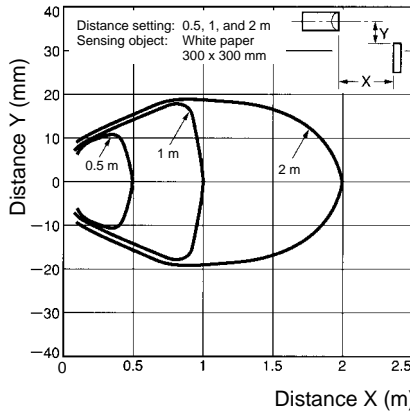

### Sensing Zone in ZONE Mode

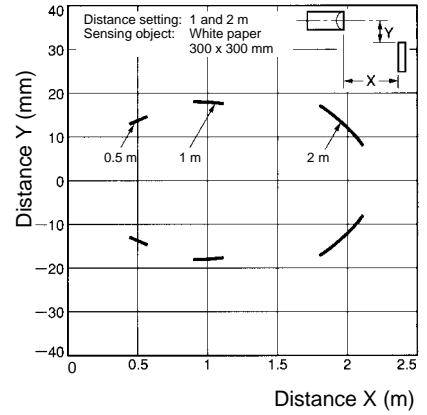

### Sensing Object Size vs. Setting Distance

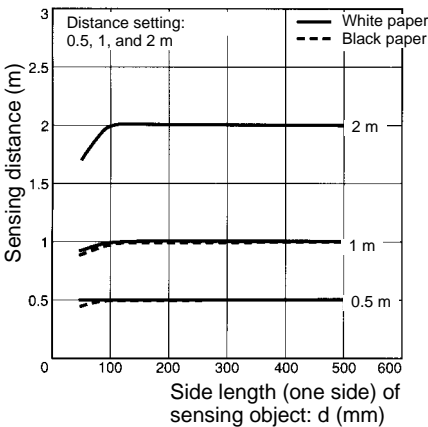

### Sensing Object Angle Characteristics (Up and Down)

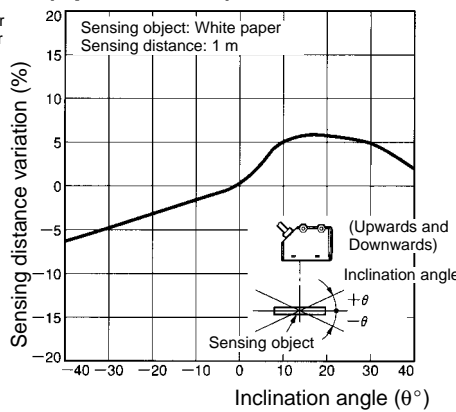

### Sensing Object Angle Characteristics (Left and Right)

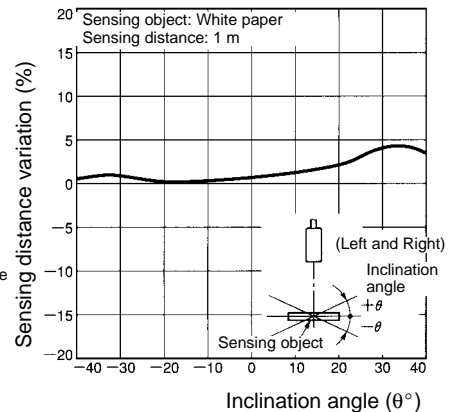

**Sensing Distance vs. Sensing Object Material (at 1-m Setting Distance)**

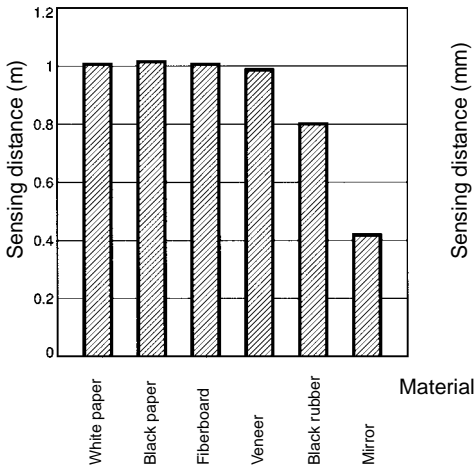

**Sensing Distance vs. Sensing Object Material (at 500-mm Setting Distance)**

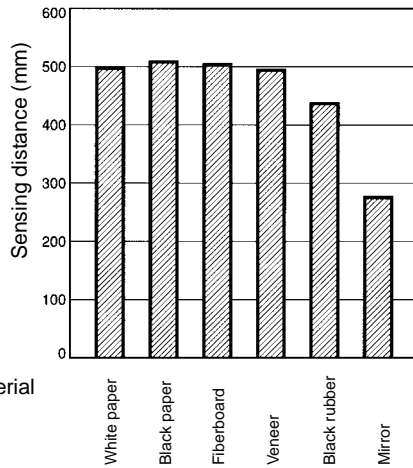

**Close-range Characteristics**

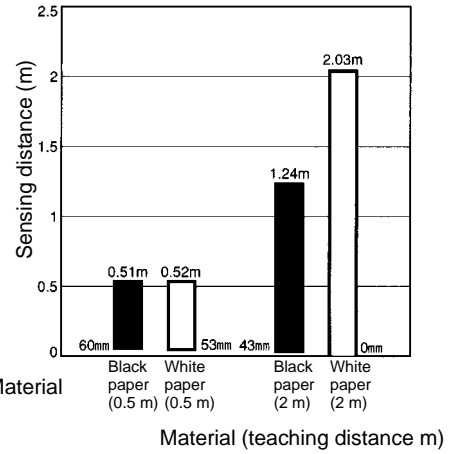

## Operation

### Output Circuits NPN/PNP Selection

Output configuration	NPN		PNP	
Model	E3G-R13 E3G-R17 E3G-L73 E3G-L77			
Output transistor status	Light ON	Dark ON	Light ON	Dark ON
Timing chart				
Mode selector	Light ON (L/ON)	Dark ON (D/ON)	Light ON (L/ON)	Dark ON (D/ON)
Output circuit	<p style="text-align: center;"><b>Connector Pin Arrangement</b></p>		<p style="text-align: center;"><b>Connector Pin Arrangement</b></p>	

Relay Output

Timer function	---	
Model	E3G-MR19 E3G-ML79	
Timing chart		
Mode selector	Light-ON (L/ON)	Dark-ON (D/ON)

Timer function	ON or OFF delay 0 to 5 s (adjustable)	
Model	E3G-MR19T E3G-ML79T	
Timing chart		
Mode selector	Light-ON (L/ON)	Dark-ON (D/ON)

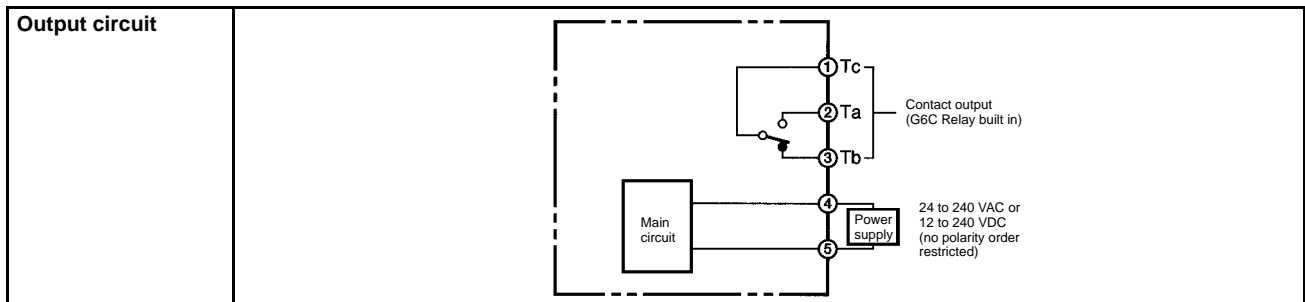

**Note:** Td1, Td2: Delay time (0 to 5 s)  
 T<sub>1</sub>: A period longer than the delay time.  
 T<sub>2</sub>: A period shorter than the delay time.  
 For ON- and OFF-delay timers, Td1 and Td2 are independently variable.

Structure of Sensor I/O Connector

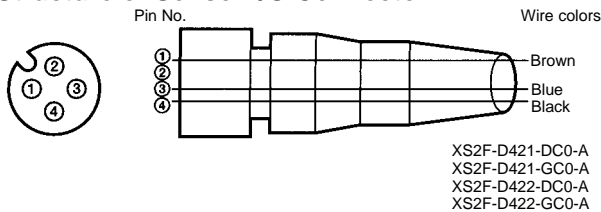

Classification	Wire color	Connector pin No.	Use
DC	Brown	1	Power supply (+V)
	---	2	---
	Blue	3	Power supply (0 V)
	Black	4	Output

**Note:** 1. Pin 2 is not used.  
 2. For details, refer to the *Sensor I/O Connectors Catalog (X065)*.

# Nomenclature

## Control Panels

### Retroreflective

E3G-R13 (Pre-wired Model)

E3G-R17 (Connector Model)

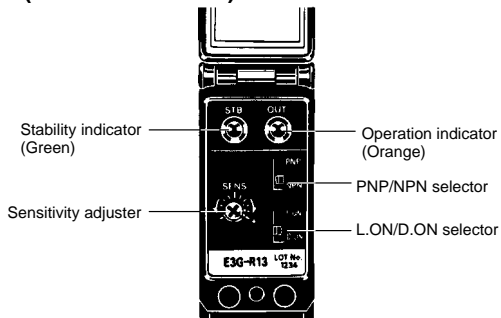

E3G-MR19 (Terminal Block Model)

E3G-MR19T (Terminal Block Model with Timer)

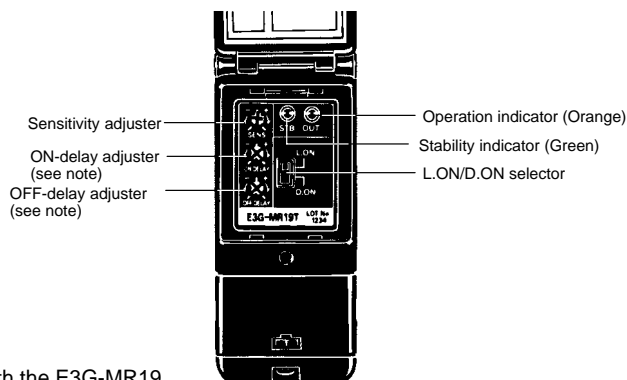

**Note:** The ON- or OFF-delay adjuster is not available with the E3G-MR19.

### Distance-setting

E3G-L73 (Pre-wired Model)

E3G-L77 (Connector Model)

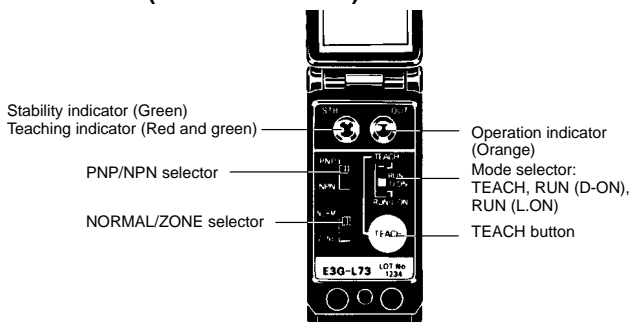

E3G-ML79 (Terminal Block Model)

E3G-ML79T (Terminal Block Model with Timer)

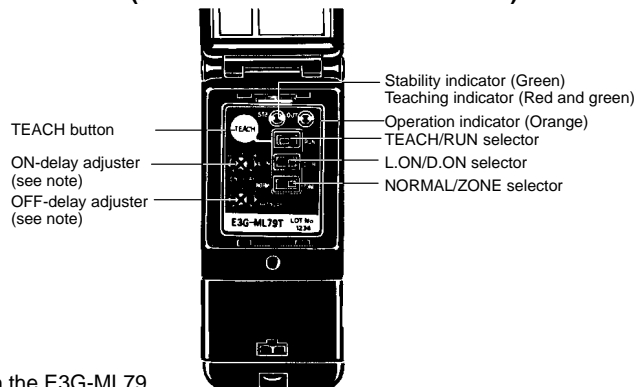

**Note:** The ON- or OFF-delay adjuster is not available with the E3G-ML79.

# Installation

## E3G-R/MR

### Designing

#### Power Supply

A power supply with full-wave rectification can be connected to the E3G-MR19(T).

#### Wiring

The tensile strength of the cable during operation should not exceed the values shown below.

Model	Tensile strength (torque)
E3G-R13, E3G-MR19(T)	50 N max.
E3G-R17	10 N max.

## Adjustments

### Indicators

The following illustration indicates the operation levels of the E3G. Set the E3G so that it will work within the stable operation range.

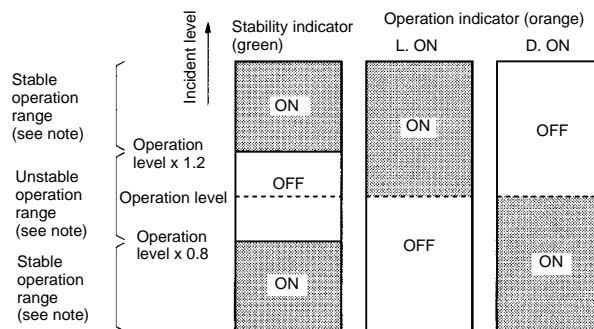

**Note:** If the operation level is set to the stable operation range, the E3G will operate with the highest reliability and without being influenced by temperature change, voltage fluctuation, dust, or setting change. If the operation level cannot be set to the stable operation range, pay close attention to environmental changes while operating the E3G.

**E3G-L/ML**

**Designing**

**Power Supply**

A power supply with full-wave rectification can be connected to the E3G-ML79(T).

**Wiring**

The tensile strength of the cable during operation should not exceed the values shown below.

Model	Tensile strength (torque)
E3G-L73, E3G-ML79(T)	50 N max.
E3G-L77	10 N max.

**Mounting**

**Mounting Directions**

Make sure that the sensing side of the Sensor is parallel with the surface of each sensing object. Do not incline the Sensor towards the sensing object.

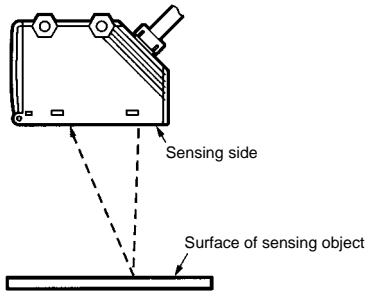

If the sensing object has a glossy surface, incline the Sensor by 5° to 10° as shown below, provided that the Sensor is not influenced by any background objects.

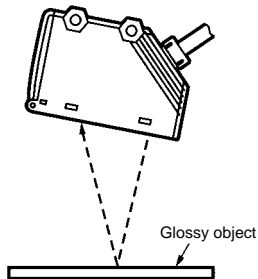

If there is a mirror-like object below the Sensor, the Sensor may not be in stable operation. Therefore, incline the Sensor or keep the Sensor a distance away from the mirror-like object as shown below.

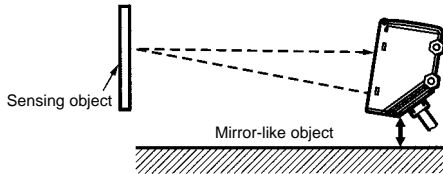

Make sure not to install the Sensor in the incorrect direction. Refer to the following.

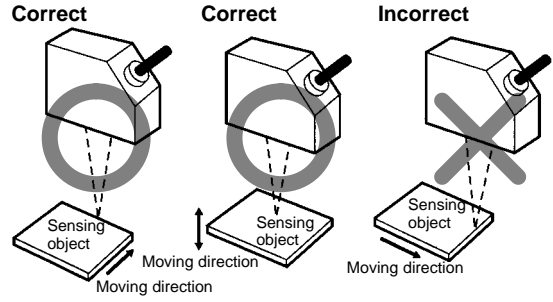

Install the Sensor as shown in the following if each sensing object greatly differs in color or material.

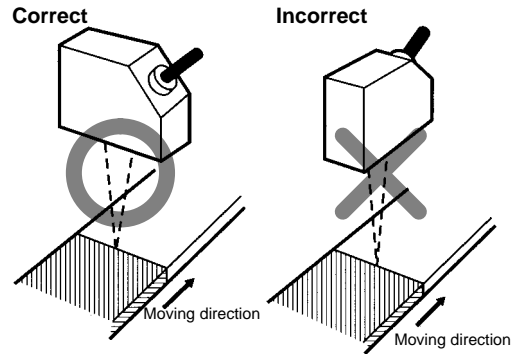

**Others**

If a teaching data error occurs with the operation indicator flashing due to a power failure or static noise, perform the teaching operation of the Sensor again.



■ E3G-L/ML

Adjustments

Adjustment Steps

1	Install, wire, and turn ON the Sensor.
2	Perform sensitivity adjustments (teaching). Refer to <i>Distance Setting (Teaching)</i> below.
3	Check that the mode selector is set to RUN.

Distance Setting (Teaching)

Select the most appropriate teaching method in reference to the following descriptions.

Application	Teaching without sensing objects (i.e., teaching the background).	Setting a threshold in the middle between the background and sensing object for operation.	Detection of glossy objects in front of the background.	Setting the maximum sensing distance of the Sensor.
Teaching	Normal one-point teaching	Normal two-point teaching	Zone teaching	Maximum distance setting (in normal mode)
Setting method	Press the TEACH button with the background object.	Press the TEACH button with the background object and with the sensing object.	Press the TEACH button with the background object (conveyor, etc.).	Press the TEACH button for longer than three seconds.
Set threshold	Threshold (a) is set to a distance in front of the background of 20% of the background distance.	Threshold (a) is set approximately in the middle between the background and sensing object.	Thresholds (a and b) are set in the sensing distance on condition that the difference between these thresholds are approximately 10% of the whole sensing distance.	The threshold is set so that the stability indicator will turn ON at approximately 2 m if the sensing object is white paper.
Output ON range	The output is ON between the Sensor and La.	The output is ON between the Sensor and La.	The output is ON between La and Lb.	The output is ON whenever the sensing object is located between the Sensor and at a distance of 2.2 m.

La: Distance equivalent to threshold (a)

Lb: Distance equivalent to threshold (b)

Normal Mode

1. Normal One-point Teaching

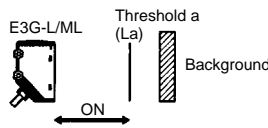

2. Normal Two-point Teaching

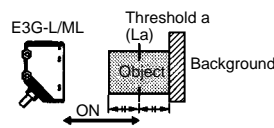

Zone Mode

Zone Teaching

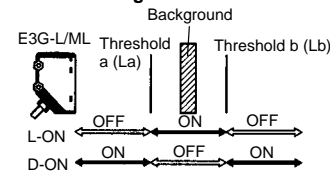

Normal One-point Teaching

Procedure	Operation
1.	Set the mode selector to TEACH.
2.	Set the NORMAL/ZONE mode selector to NORMAL.
3.	Press the TEACH button with no sensing object (i.e., teach the background). The teaching indicator (red) will turn ON.
4.	Set the mode selector to RUN. (Set to L-ON or D-ON mode.)

Note: Perform normal one-point teaching with the background.

Zone Teaching

Procedure	Operation
1.	Set the mode selector to TEACH.
2.	Set the NORMAL/ZONE mode selector to ZONE.
3.	Press the TEACH button with the background. <ul style="list-style-type: none"> <li>The teaching indicator (red) will turn ON first. Then the teaching indicator (green) will turn ON.</li> </ul>
4.	Set the mode selector to RUN. (Set to L-ON or D-ON mode.)

Note: Perform zone teaching with the background.

Normal Two-point Teaching

Procedure	Operation
1.	Set the mode selector to TEACH.
2.	Set the NORMAL/ZONE mode selector to NORMAL.
3.	Press the TEACH button with a sensing object located at the sensing position. The teaching indicator (red) will turn ON.
4.	Move the sensing object and press the TEACH button with the background. <ul style="list-style-type: none"> <li>If the teaching is successful, the teaching indicator (green) will turn ON.</li> <li>If the teaching is not successful, the teaching indicator (red) will start to flash.</li> </ul>
5.	If the teaching is successful, set the mode selector to RUN to complete the teaching operation. Set the E3G to light- or dark-ON mode with the mode selector according to the application. If the teaching is not successful, change the set distance and object sensing position and repeat two-point teaching from step 3.

Maximum Distance Setting (in Normal Mode)

Procedure	Operation
1.	Set the mode selector to TEACH.
2.	Set the NORMAL/ZONE mode selector to NORMAL.
3.	Press the TEACH button for 3 s or more. <ul style="list-style-type: none"> <li>The teaching indicator (red) will turn ON.</li> <li>The teaching indicator (green) will turn ON in 3 s. This means that teaching was successful.</li> </ul>
4.	If the teaching is successful, set the mode selector to RUN to complete the teaching operation. (Set to L-ON or D-ON mode.)

## ■ E3G-M□(T)

### Wiring

The cable with an external diameter of 6 to 8 mm is recommended.

Be sure to attach the cover with screws securely in order to maintain the water- and dust-resistive properties of the product.

The conduit screw size is JIS B0202 PF1/2.

### Terminal Cover

Do not tighten the terminal protection cover with wires pinched between the Sensor and the cover in order to maintain the water- and dust-resistive properties of the product.

#### Recommended Example

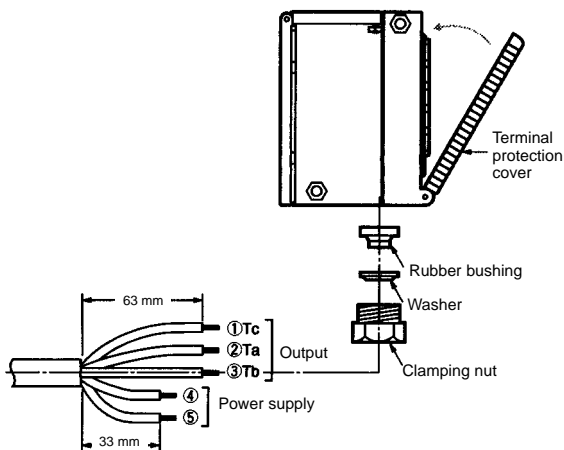

## Changing to Side-pullout Cable from Vertical-pullout Cable

### Procedure

1. Remove the present cover.
2. Attach the E39-L129 Terminal Protection Cover for side-pullout cable.
3. Remove the clamping nut, washer, and rubber bushing of the E3G. These are used for the side-pullout cable.
4. Attach the rubber bushing and cap provided with the E39-L129 to the E3G as replacements.

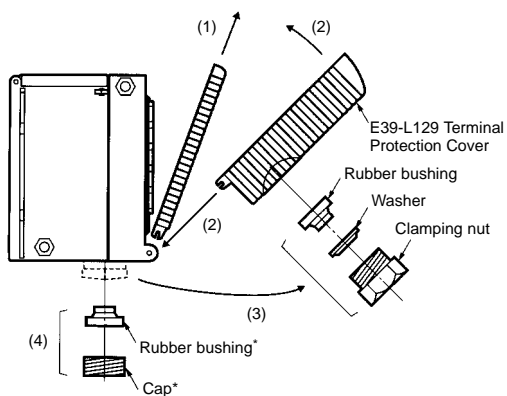

**Note:** \*Provided with the E39-L129.

## ■ All E3G Models

### Designing

#### Load Relay Contact

If E3G is connected to a load with contacts that spark when the load is turned OFF (e.g., a contactor or valve), the normally-closed side may be turned ON before the normally-open side is turned OFF or vice-versa. If both normally-open output and normally-closed output are used simultaneously, apply a surge suppressor to the load. Refer to OMRON's *PCB Relays Catalog (X33)* for typical examples of surge suppressors.

#### Power Reset Time

The Sensor needs 100 ms to be ready to operate after it is turned ON. The devices connected to the Photoelectric Sensor must wait until the Sensor is ready to operate. If the Sensor and load are connected to separate power supplies, be sure to turn ON the Sensor first.

#### Power OFF

A single pulse signal may be output from the Sensor immediately after it is turned OFF. This will occur more frequently if a timer or counter is connected to the Sensor and power is supplied to the timer or counter independently. Therefore, be sure to supply power to the timer or counter from the built-in power supply of the Sensor.

#### Power Supply

If a standard switching regulator is used, be sure to ground the FG (frame ground) and G (ground) terminals, otherwise the Sensor may malfunction due to the switching noise of the regulator.

#### Repeated Cable Bending

Do not bend the sensor cable repeatedly.

#### High-tension Lines

Do not wire power lines or high-tension lines alongside the lines of the Sensor in the same conduit, otherwise the Sensor may be damaged or may malfunction due to induction. Be sure to wire the lines of the Sensor separated from power lines or high-tension lines or laid in an exclusive, shielded conduit.

### Wiring

The E3G has a built-in function to protect the E3G from load short-circuiting. If load short-circuiting results, the output will be turned OFF. In that case, check the wiring and turn ON the E3G again so that the short-circuit protection circuit will be reset. This function will operate if the output current flow is at least 2.0 times the rated load current. If an inductive load is connected to the E3G, make sure that the inrush current does not exceed 1.2 times the rated load current.

The cable can be extended up to a total length of 100 m, on condition that the thickness of the wire is at least 0.3 mm.

### Mounting

#### Mounting Conditions

If Sensors are mounted face-to-face, make sure that no optical axes cross each other. Otherwise, mutual interference may result.

Be sure to install the Sensor carefully so that the directional angle range of the Sensor will not be directly exposed to intensive light, such as sunlight, fluorescent light, or incandescent light.

Do not strike the Photoelectric Sensor with a hammer or any other tool during the installation of the Sensor, or the Sensor will lose its water-resistive properties.

Use M4 screws to mount the Sensor.

When mounting the case, make sure that the tightening torque applied to each screw does not exceed 1.2 N • m.

**M12 Connector**

Be sure to connect or disconnect the M12 connector after turning OFF the Sensor.

Be sure to hold the connector cover when connecting or disconnecting the M12 connector.

Secure the M12 connector by hand. Do not use any pliers, otherwise the connector may be damaged.

If the M12 connector is not connected securely, the proper degree of protection of the Sensor may not be maintained or the connector may be disconnected due to vibration.

**Water Resistance**

Do not use the product in water, in rain, or outdoors.

Tighten the operation cover screws and terminal block cover screws to a torque of 0.3 to 0.5 N • m in order to ensure water resistivity.

**Maintenance and Inspection****Cleaning**

Paint thinner damages the casing of the E3G. Do not apply paint thinner to clean the E3G.

**Others****Operating Environment**

Do not install the E3G in the following locations, otherwise the E3G may malfunction.

- Places with excessive dust.
- Places with corrosive gases.
- Locations directly exposed to sprays of water, oil, or chemicals.
- Locations where the product is directly exposed to vibration or shock.

# Dimensions

Note: All units are in millimeters unless otherwise indicated.

## ■ Sensors

### Retroreflective Models

#### E3G-R13 Pre-wired Model

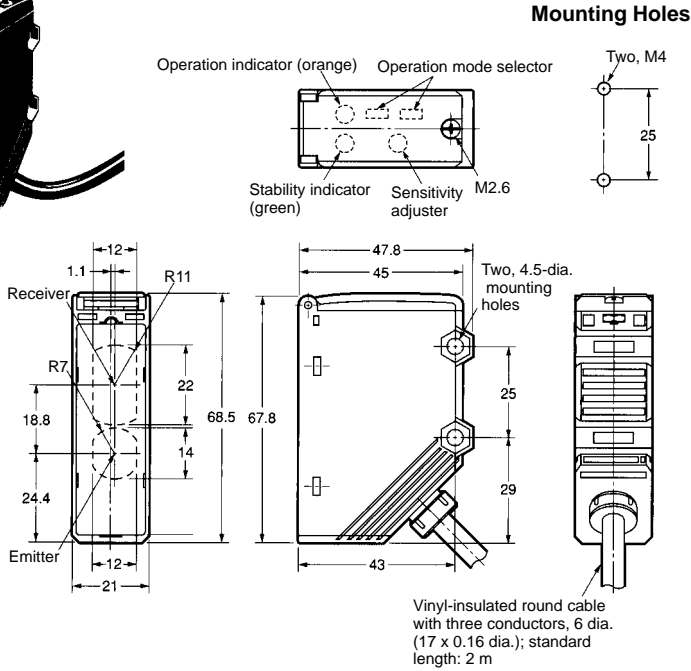
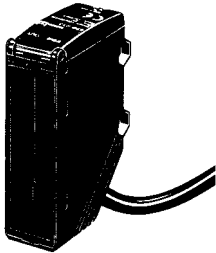

#### E3G-R17 Connector Model

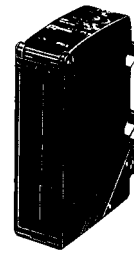

Note: All dimensions other than the ones specified below are the same as the corresponding dimensions of E3G-R13.

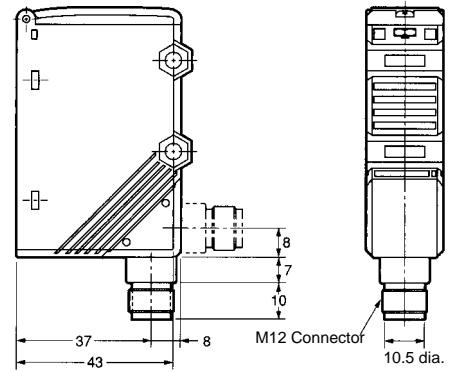

#### E3G-MR19 and E3G-MR19T Terminal Block Models

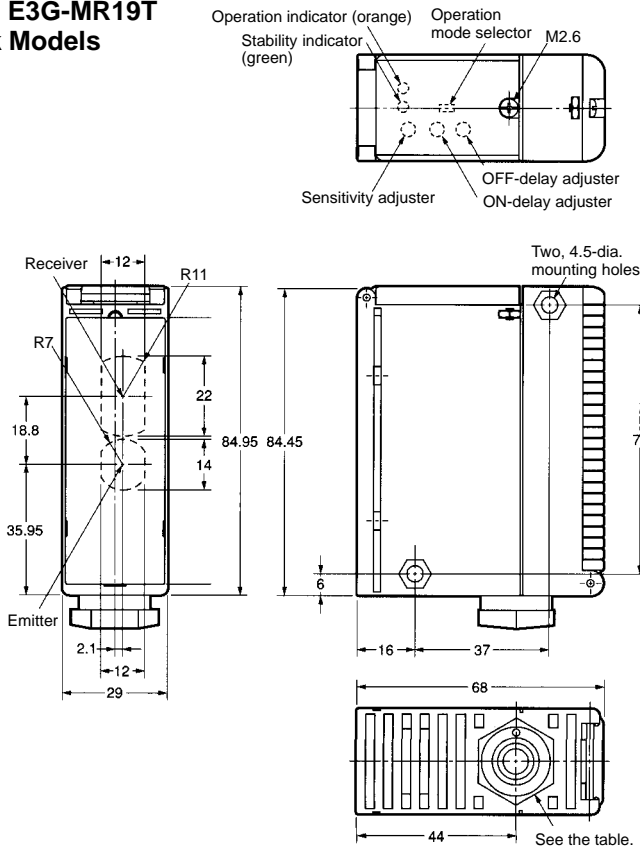
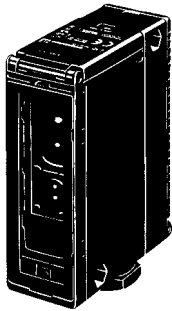

Note: The ON- or OFF-delay adjuster is not available with the E3G-MR19.

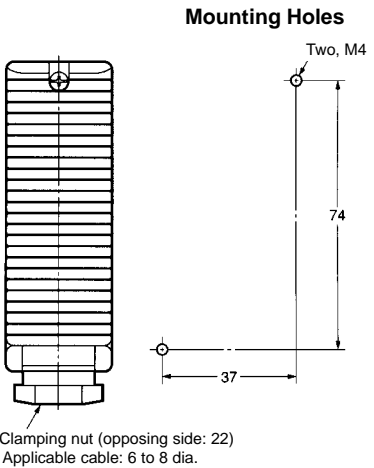

Conduit	Suffix code
PF $\frac{1}{2}$ (JIS B0202)	None
PG13.5 (CENELEC)	-G
$\frac{1}{2}$ -14NPT	-US

Distance-setting Models

E3G-L73 Pre-wired Model

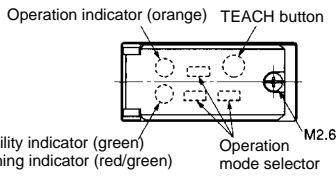
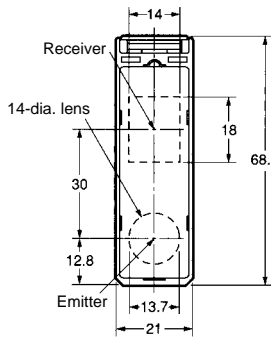
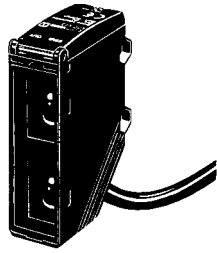

Mounting Holes

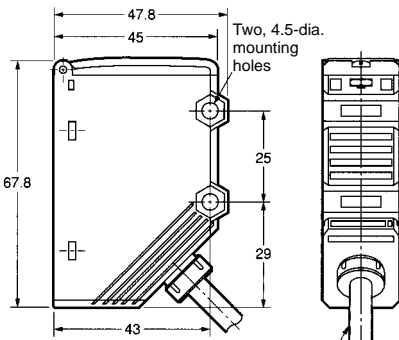
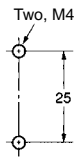

Vinyl-insulated round cable with three conductors, 6 dia. (17 x 0.16 dia.); standard length: 2 m

E3G-L77 Connector Model

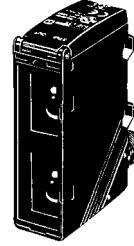

Note: All dimensions other than the ones specified below are the same as the corresponding dimensions of the E3G-L73.

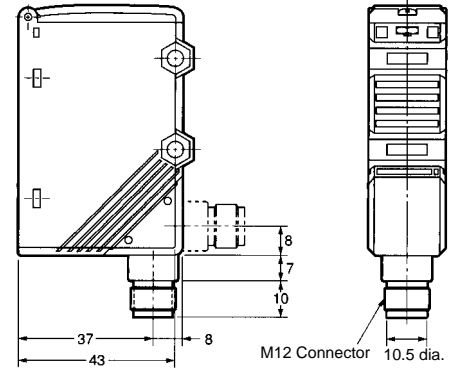

E3G-ML79 and E3G-ML79T Terminal Block Models

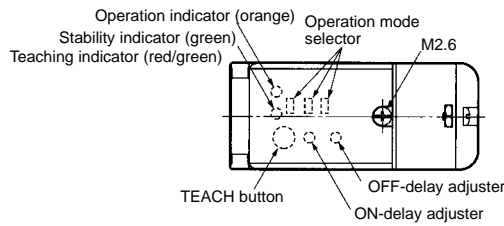
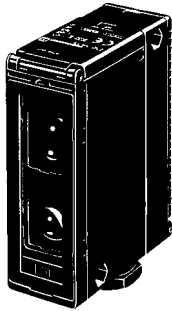

Note: The ON- or OFF-delay adjuster is not available with the E3G-ML79.

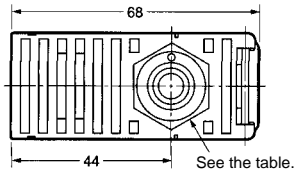
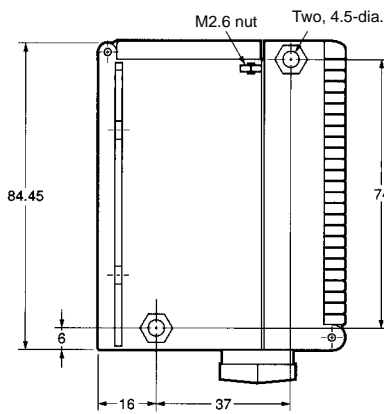
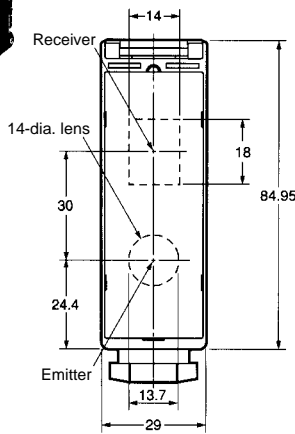

Mounting Holes

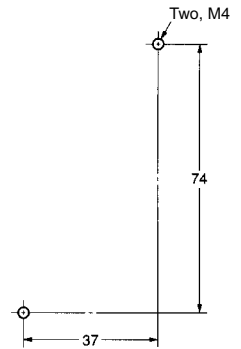

Clamping nut (opposing side: 22)  
Applicable cable: 6 to 8 dia.

Conduit	Suffix code
PF $\frac{1}{2}$ (JIS B0202)	None
PG13.5 (CENELEC)	-G
$\frac{1}{2}$ -14NPT	-US

■ Accessories (Order Separately)

Reflectors

E39-R2

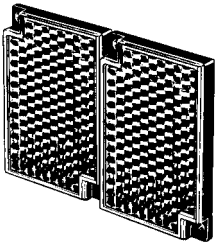

Material  
Surface: Acrylic resin  
Backside: ABS resin

Note: Supplied with E3G-R□□, E3G-MR□□, and E3G-MR□□-US.

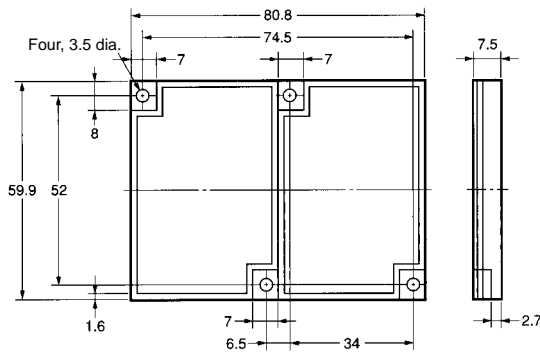

E39-R1

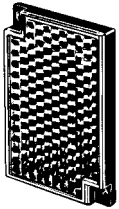

Material  
Surface: Acrylic resin  
Backside: ABS resin

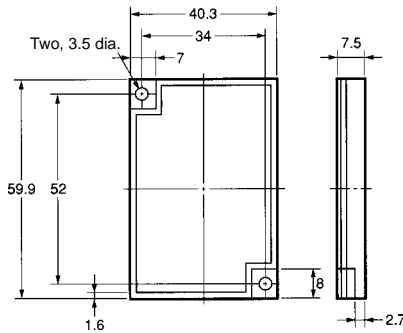

Terminal Protection Cover for Side-pullout Cable

E39-L129

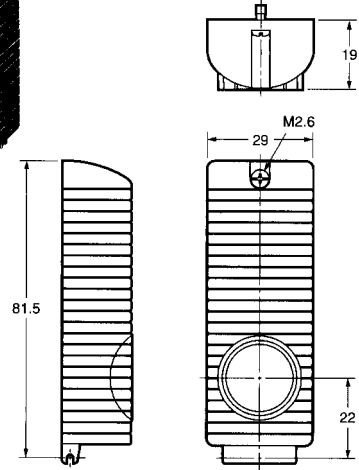

- Note:
1. The cover is provided with a rubber bushing and cap to prevent the cable from being pulled out vertically.
  2. Refer to page 10 for the mounting method of the product.

Mounting Brackets

E39-L131

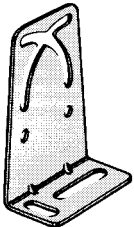

Material: Stainless steel (SUS304)

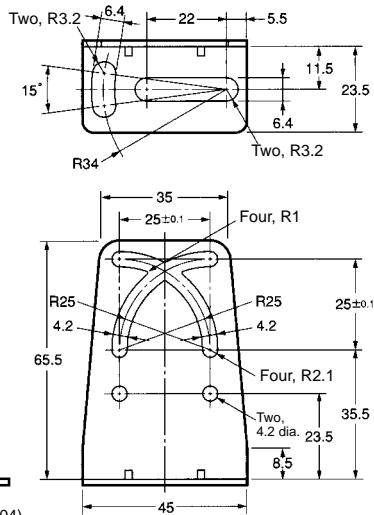

E39-L132

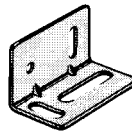

Material: Stainless steel (SUS304)

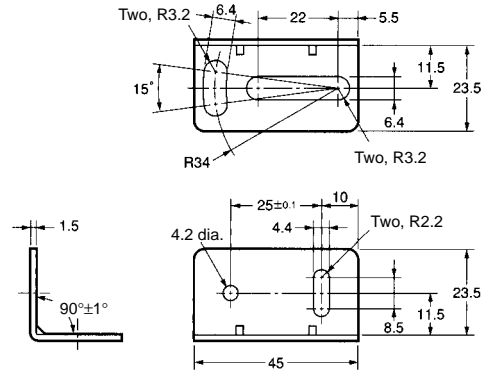

E39-L135

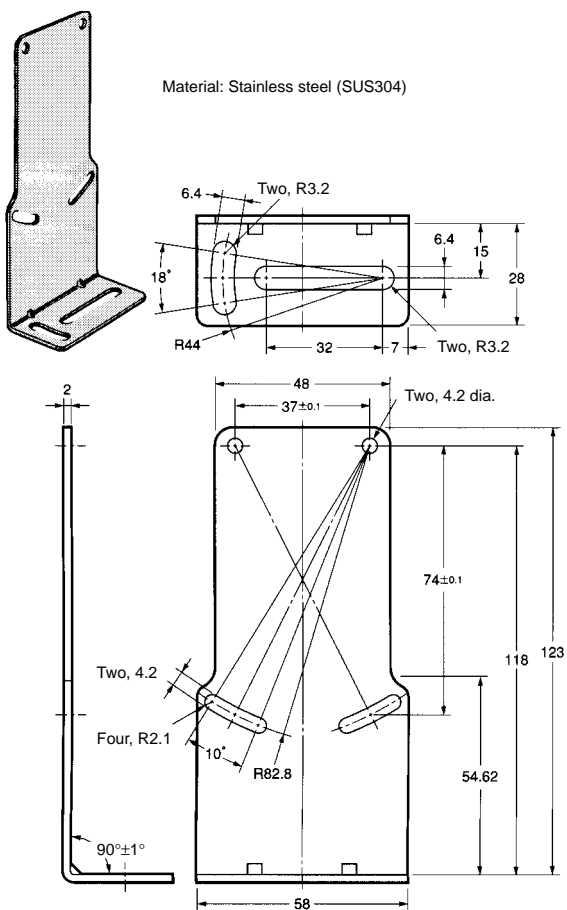

E39-L136

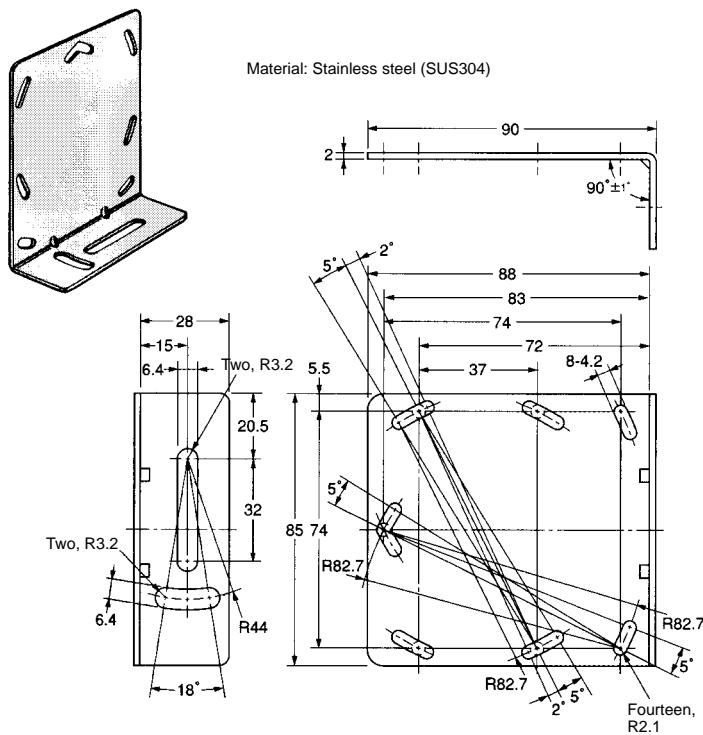

Sensor I/O Connectors

Straight

- XS2F-D421-DC0-A (L=2 m)
- XS2F-D421-GC0-A (L=5 m)

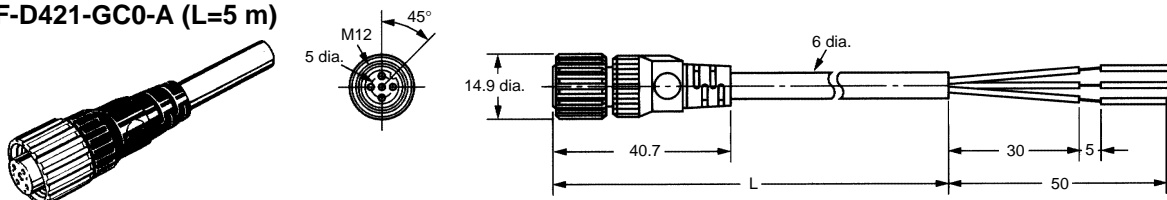

L-shaped

- XS2F-D422-DC0-A (L=2 m)
- XS2F-D422-GC0-A (L=5 m)

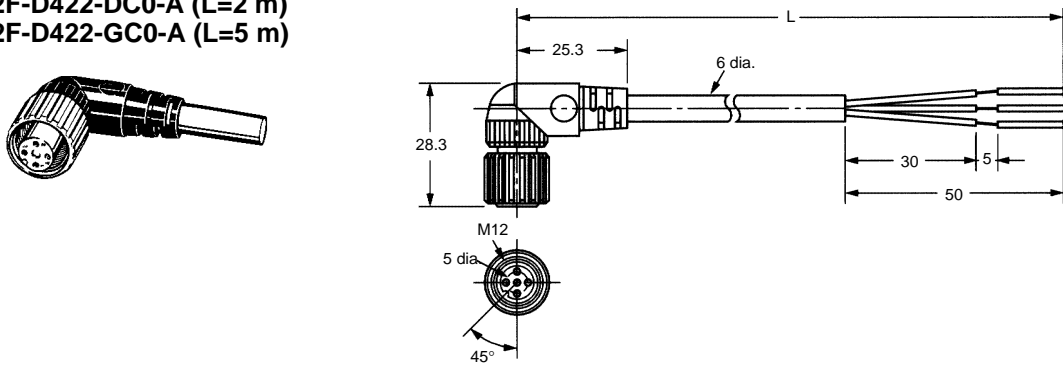

## Precautions

---

Do not ignore the following items that are essential for securing safety during Sensor operation.

- Do not use the Sensor in locations with explosive or flammable gas.
- Do not use the Sensor in the water or electrically conductive solutions.
- Do not disassemble, repair, or modify the product.
- Make sure that the power supply specifications, such as AC or DC, are correct.
- Do not apply voltage or current exceeding the rated ranges.
- Do not make mistakes in wiring, such as mistakes in polarity.
- Be sure to connect the load correctly.
- Do not short-circuit the load terminals.

**ALL DIMENSIONS SHOWN ARE IN MILLIMETERS.**

To convert millimeters into inches, multiply by 0.03937. To convert grams into ounces, multiply by 0.03527.

Cat. No. E278-E1-2 **In the interest of product improvement, specifications are subject to change without notice.**

### OMRON Corporation

Industrial Sensors Division  
Sensing Devices and Components Division H.Q.  
28th Fl., Crystal Tower Bldg.,  
1-2-27, Shiromi, Chuo-ku,  
Osaka 540-6028 Japan  
Phone: (81)6-6949-6012 Fax: (81)6-6949-6021

Printed in Japan  
1298-3M (0998) Ⓐ