

Projet 7 - MLI-PI / Correcteur PI et commande MLI d'un hacheur

Projet : IUT3
Info : [DIV421]
Révision : 1 du mercredi 11 février 2004.
Révision : 2 du 28 février 2004.
Révision : 3 du 11 mars 2004.

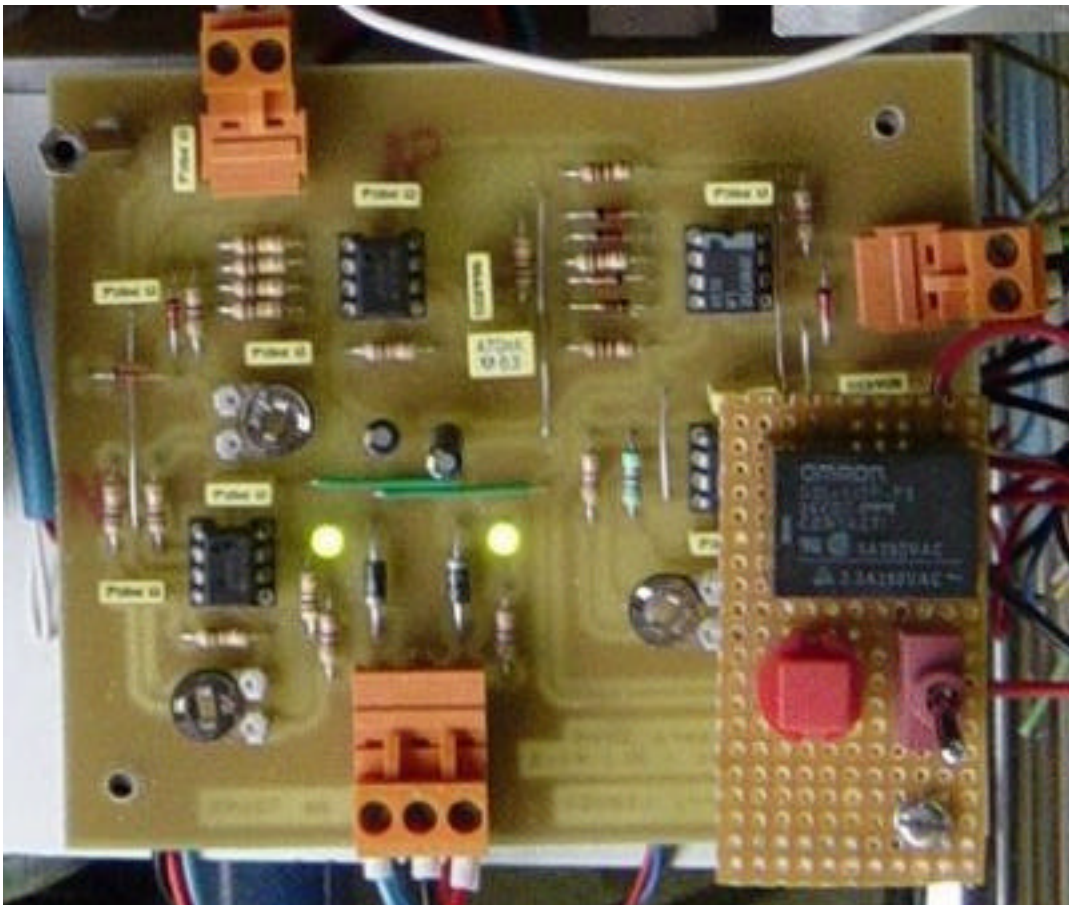


Figure 7.1. Maquette (images-maquettes\mli-pi-22.jpg).

7.1 Liste des documents

- Prix du montage.
- Schéma électronique.
- Circuit imprimé coté cuivre.
- Circuit imprimé coté composants.
- Implantation des composants.
- Documentations.

7.2 Désignation des composants

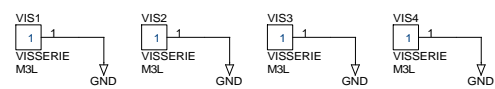
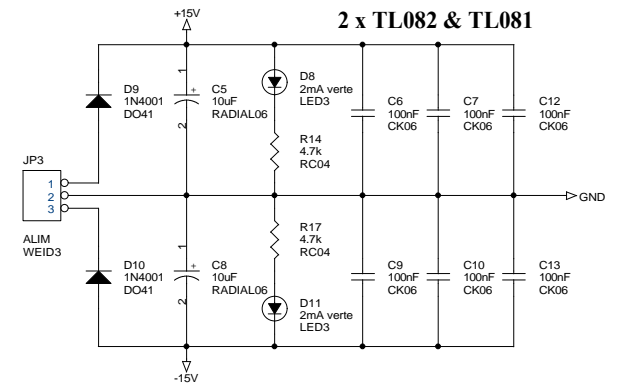
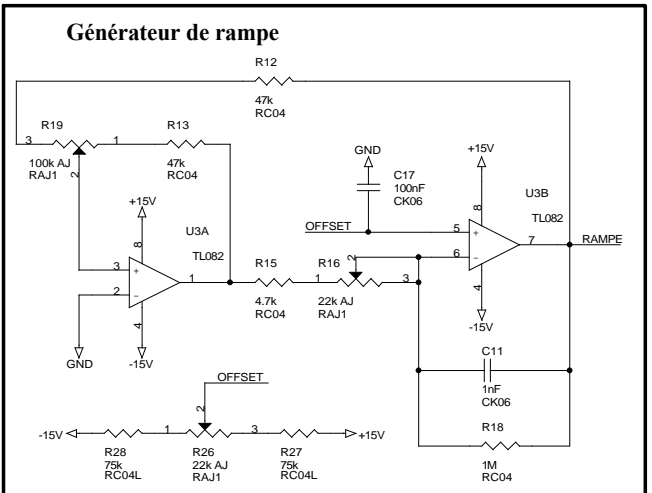
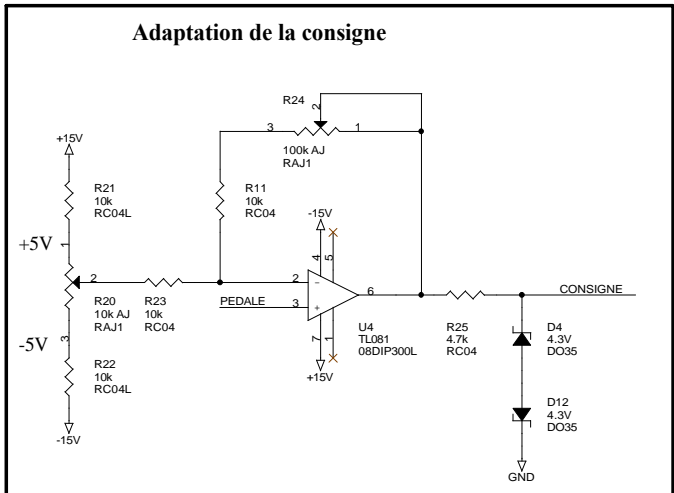
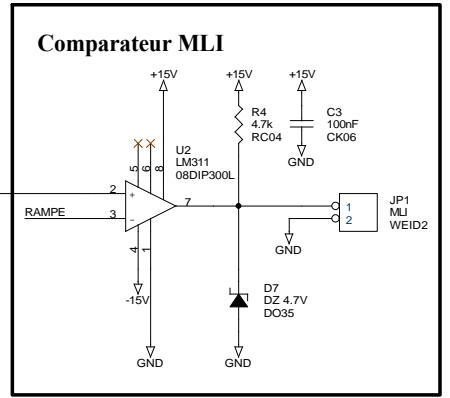
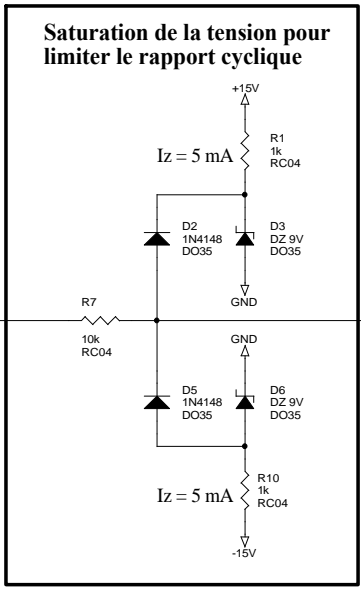
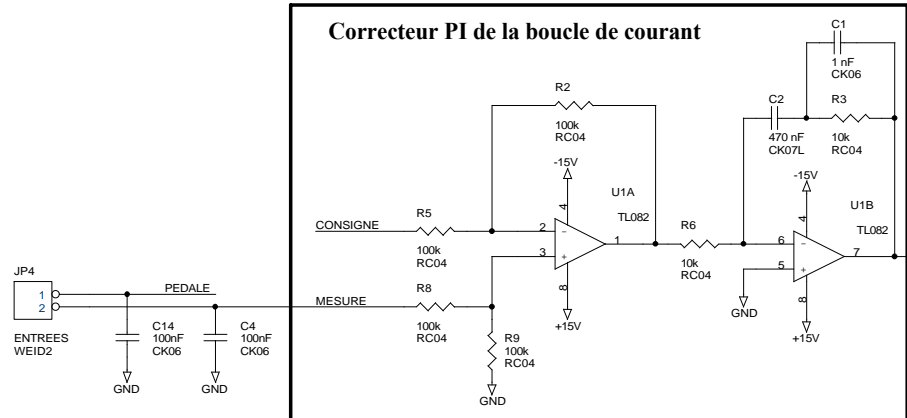
Tableau 7.1. Liste de composants (projets-iut3.xls / MLI-PI).

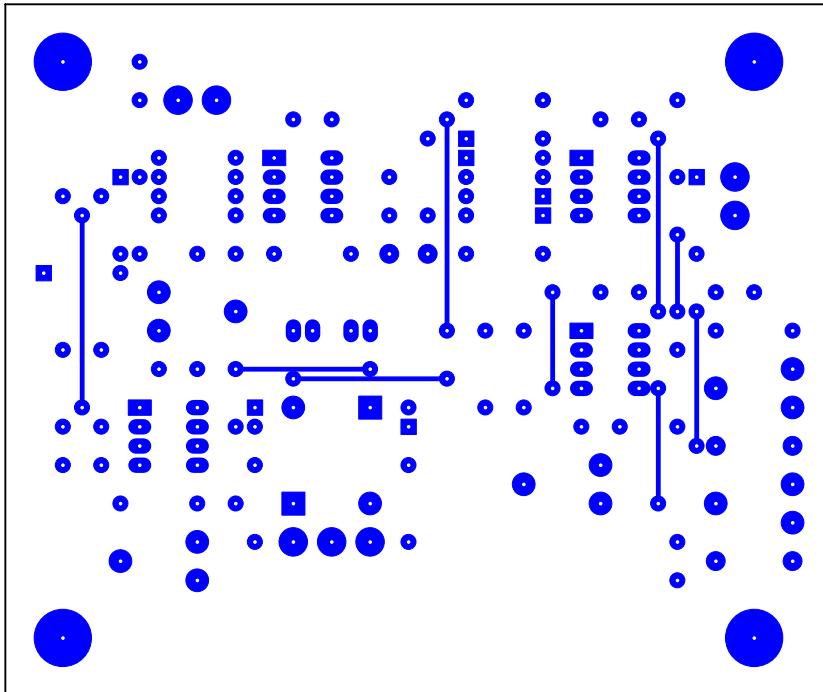
N°	Quantité	Référence	Désignation	Empreinte
1	1	C1	1nF	CK06
2	1	C2	1uF	C6PAS
3	6	C3,C4,C6,C7,C9,C10	100nF	CK06
4	2	C5,C8	10uF	RADIAL06
5	1	C11	10nF	CK06
6	4	D1,D2,D4,D5	1N4148	DO35
7	2	D3,D6	DZ 9V	DO41-4P
8	1	D7	DZ 3.3V	DO41-4P
9	2	D8,D11	3mA verte	LED3
10	2	D10,D9	1N4001	DO41
11	1	JP1	MLI	02PL2
12	1	JP2	ENTREE	03PL2
13	1	JP3	ALIM	03PL2
14	1	J1	BNC	BNC1
15	4	R1,R4,R10,R15	1k	RC04
16	6	R2,R5,R6,R7,R8,R9	10k	RC04
17	1	R3	20k	RC04
18	1	R11	100	RC04
19	2	R13,R12	47k	RC04
20	2	R14,R17	4.7k	RC04
21	1	R16	47k	RAJ1
22	1	R18	1M	RC04
23	1	R19	100k	RAJ1
24	2	U1,U3	TL082	08DIP300L
25	1	U2	LM311	08DIP300L

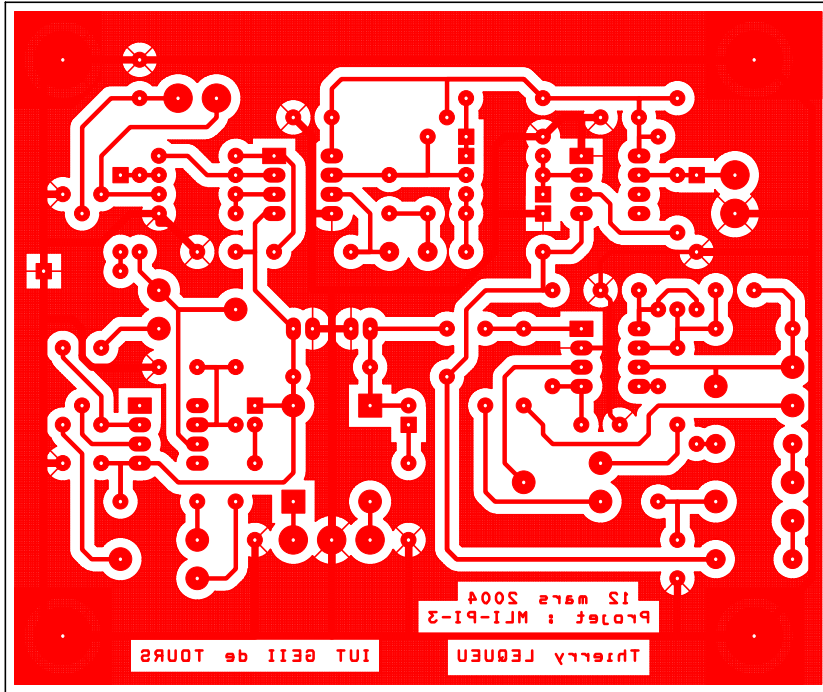
7.3 Allure des principaux composants

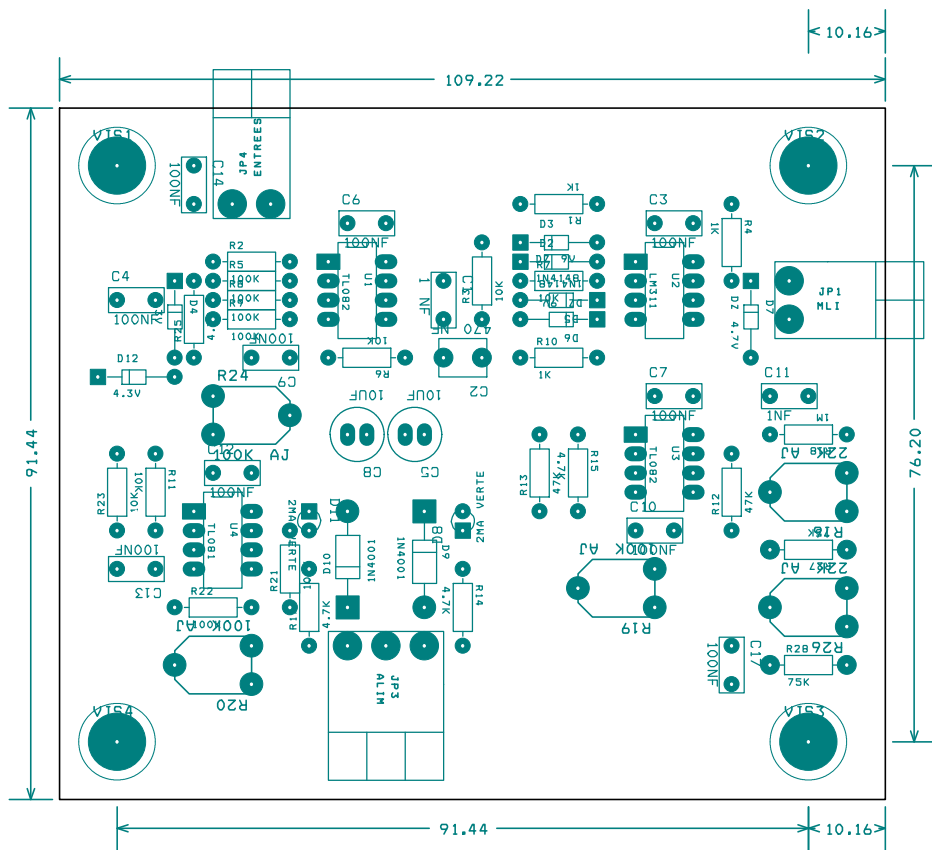


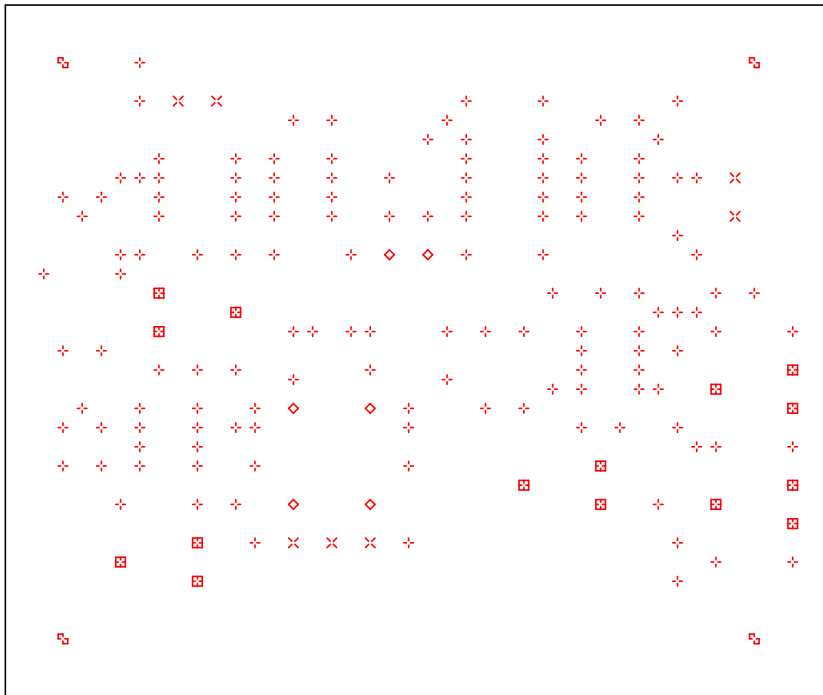
Fig. 7.2. Bornier CANDEM 3 points (images-composants\bornier1.jpg).











DRILL CHART				
SYM	DIAM	TOL	QTY	NOTE
+	0.031		142	
◇	0.039		6	
⊞	0.047		15	
×	0.059		7	
⊞	0.126		4	
TOTAL			174	

LM111/LM211/LM311 Voltage Comparator

1.0 General Description

The LM111, LM211 and LM311 are voltage comparators that have input currents nearly a thousand times lower than devices like the LM106 or LM710. They are also designed to operate over a wider range of supply voltages: from standard $\pm 15V$ op amp supplies down to the single 5V supply used for IC logic. Their output is compatible with RTL, DTL and TTL as well as MOS circuits. Further, they can drive lamps or relays, switching voltages up to 50V at currents as high as 50 mA.

Both the inputs and the outputs of the LM111, LM211 or the LM311 can be isolated from system ground, and the output can drive loads referred to ground, the positive supply or the negative supply. Offset balancing and strobe capability are provided and outputs can be wire OR'ed. Although slower than the LM106 and LM710 (200 ns response time vs 40 ns)

the devices are also much less prone to spurious oscillations. The LM111 has the same pin configuration as the LM106 and LM710.

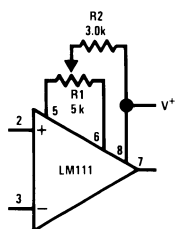
The LM211 is identical to the LM111, except that its performance is specified over a $-25^{\circ}C$ to $+85^{\circ}C$ temperature range instead of $-55^{\circ}C$ to $+125^{\circ}C$. The LM311 has a temperature range of $0^{\circ}C$ to $+70^{\circ}C$.

2.0 Features

- Operates from single 5V supply
- Input current: 150 nA max. over temperature
- Offset current: 20 nA max. over temperature
- Differential input voltage range: $\pm 30V$
- Power consumption: 135 mW at $\pm 15V$

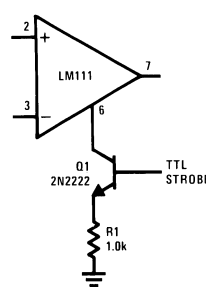
3.0 Typical Applications (Note 3)

Offset Balancing



DS005704-36

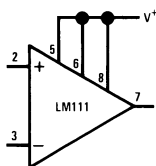
Strobing



DS005704-37

Note: Do Not Ground Strobe Pin. Output is turned off when current is pulled from Strobe Pin.

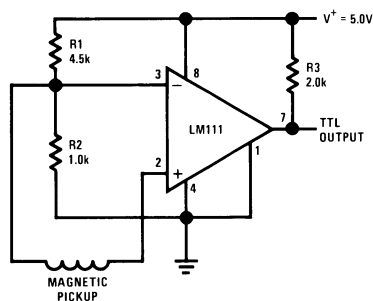
Increasing Input Stage Current (Note 1)



DS005704-38

Note 1: Increases typical common mode slew from $7.0V/\mu s$ to $18V/\mu s$.

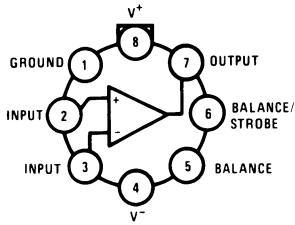
Detector for Magnetic Transducer



DS005704-39

11.0 Connection Diagrams

Metal Can Package



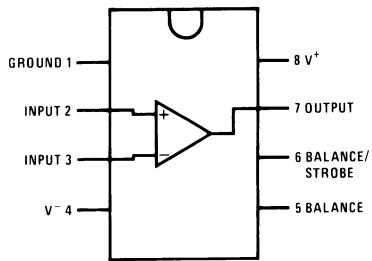
DS005704-6

Note: Pin 4 connected to case

Top View

Order Number LM111H, LM111H/883(Note 21) , LM211H or LM311H
See NS Package Number H08C

Dual-In-Line Package

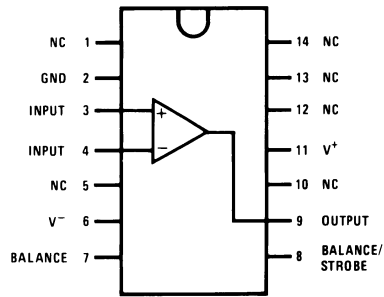


DS005704-34

Top View

Order Number LM111J-8, LM111J-8/883(Note 21),
LM311M, LM311MX or LM311N
See NS Package Number J08A, M08A or N08E

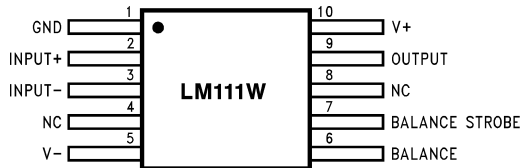
Dual-In-Line Package



DS005704-35

Top View

Order Number LM111J/883(Note 21)
See NS Package Number J14A or N14A



DS005704-33

Order Number LM111W/883(Note 21), LM111WG/883
See NS Package Number W10A, WG10A

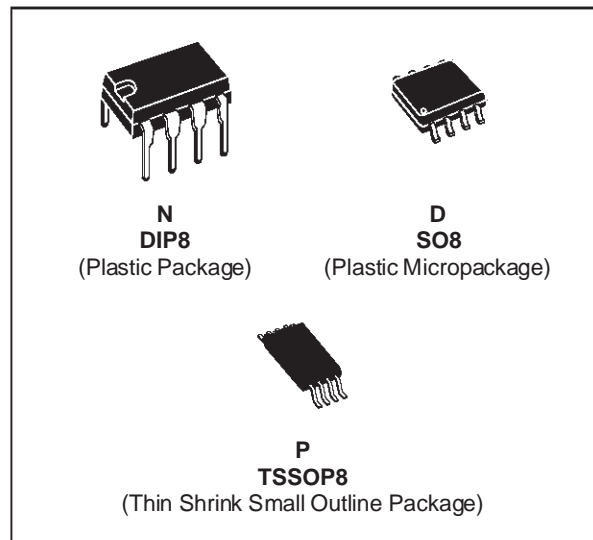
Note 21: Also available per JM38510/10304



TL082 TL082A - TL082B

GENERAL PURPOSE J-FET DUAL OPERATIONAL AMPLIFIER

- WIDE COMMON-MODE (UP TO V_{CC}^+) AND DIFFERENTIAL VOLTAGE RANGE
- LOW INPUT BIAS AND OFFSET CURRENT
- OUTPUT SHORT-CIRCUIT PROTECTION
- HIGH INPUT IMPEDANCE J-FET INPUT STAGE
- INTERNAL FREQUENCY COMPENSATION
- LATCH UP FREE OPERATION
- HIGH SLEW RATE : $16V/\mu s$ (typ)



DESCRIPTION

The TL082, TL082A and TL082B are high speed J-FET input dual operational amplifiers incorporating well matched, high voltage J-FET and bipolar transistors in a monolithic integrated circuit.

The devices feature high slew rates, low input bias and offset current, and low offset voltage temperature coefficient.

ORDER CODES

Part Number	Temperature Range	Package		
		N	D	P
TL082M/AM/BM	-55°C, +125°C	•	•	•
TL082I/AI/BI	-40°C, +105°C	•	•	•
TL082C/AC/BC	0°C, +70°C	•	•	•

Examples : TL082CD, TL082IN

PIN CONNECTIONS (top view)

