



±15kV ESD-Protected, 1µA, 16Mbps, Dual/Quad Low-Voltage Level Translators in UCSP

General Description

The MAX3372E–MAX3379E and MAX3390E–MAX3393E ±15kV ESD-protected level translators provide the level shifting necessary to allow data transfer in a multivoltage system. Externally applied voltages, V_{CC} and V_L , set the logic levels on either side of the device. A low-voltage logic signal present on the V_L side of the device appears as a high-voltage logic signal on the V_{CC} side of the device, and vice-versa. The MAX3374E/MAX3375E/MAX3376E/MAX3379E and MAX3390E–MAX3393E unidirectional level translators level shift data in one direction ($V_L \rightarrow V_{CC}$ or $V_{CC} \rightarrow V_L$) on any single data line. The MAX3372E/MAX3373E and MAX3377E/MAX3378E bidirectional level translators utilize a transmission-gate-based design (Figure 2) to allow data translation in either direction ($V_L \leftrightarrow V_{CC}$) on any single data line. The MAX3372E–MAX3379E and MAX3390E–MAX3393E accept V_L from +1.2V to +5.5V and V_{CC} from +1.65V to +5.5V, making them ideal for data transfer between low-voltage ASICs/PLDs and higher voltage systems.

All devices in the MAX3372E–MAX3379E, MAX3390E–MAX3393E family feature a three-state output mode that reduces supply current to less than 1µA, thermal short-circuit protection, and ±15kV ESD protection on the V_{CC} side for greater protection in applications that route signals externally. The MAX3372E/MAX3377E operate at a guaranteed data rate of 230kbps. Slew-rate limiting reduces EMI emissions in all 230kbps devices. The MAX3373E–MAX3376E/MAX3378E/MAX3379E and MAX3390E–MAX3393E operate at a guaranteed data rate of 8Mbps over the entire specified operating voltage range. Within specific voltage domains, higher data rates are possible. (See the *Timing Characteristics*.)

The MAX3372E–MAX3376E are dual level shifters available in 3 x 3 UCSP™ and 8-pin SOT23-8 packages. The MAX3377E/MAX3378E/MAX3379E and MAX3390E–MAX3393E are quad level shifters available in 3 x 4 UCSP and 14-pin TSSOP packages.

Applications

- SPI™, MICROWIRE™, and I²C* Level Translation
- Low-Voltage ASIC Level Translation
- Smart Card Readers
- Cell-Phone Cradles
- Portable POS Systems
- Portable Communication Devices
- Low-Cost Serial Interfaces
- Cell Phones
- GPS
- Telecommunications Equipment

Features

- ◆ **Guaranteed Data Rate Options**
 - 230kbps
 - 8Mbps (+1.2V ≤ V_L ≤ V_{CC} ≤ +5.5V)
 - 10Mbps (+1.2V ≤ V_L ≤ V_{CC} ≤ +3.3V)
 - 16Mbps (+1.8V ≤ V_L ≤ V_{CC} ≤ +2.5V and +2.5V ≤ V_L ≤ V_{CC} ≤ +3.3V)
- ◆ **Bidirectional Level Translation (MAX3372E/MAX3373E and MAX3377E/MAX3378E)**
- ◆ **Operation Down to +1.2V on V_L**
- ◆ **±15kV ESD Protection on I/O V_{CC} Lines**
- ◆ **Ultra-Low 1µA Supply Current in Three-State Output Mode**
- ◆ **Low-Quiescent Current (130µA typ)**
- ◆ **UCSP, SOT, and TSSOP Packages**
- ◆ **Thermal Short-Circuit Protection**

Ordering Information

PART	TEMP RANGE	PIN-PACKAGE	PKG CODE
MAX3372EKA-T	-40°C to +85°C	8 SOT23-8	K8S-3

Ordering Information continued at end of data sheet.
Selector Guide appears at end of data sheet.

UCSP is a trademark of Maxim Integrated Products, Inc.

SPI is a trademark of Motorola, Inc.

MICROWIRE is a trademark of National Semiconductor Corp.

Purchase of I²C components of Maxim Integrated Products, Inc., or one of its sublicensed Associated Companies, conveys a license under the Philips I²C Patent Rights to use these components in an I²C system, provided that the system conforms to the I²C Standard Specification as defined by Philips.

Pin Configurations

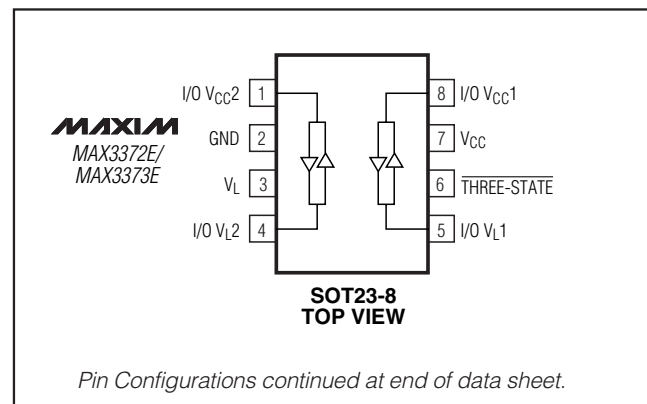

±15kV ESD-Protected, 1µA, 16Mbps, Dual/Quad Low-Voltage Level Translators in UCSP

ABSOLUTE MAXIMUM RATINGS

All Voltages Referenced to GND

V _{CC}	-0.3V to +6V
I/O V _{CC_}	-0.3V to (V _{CC} + 0.3V)
I/O V _{L_}	-0.3V to (V _L + 0.3V)
THREE-STATE	-0.3V to (V _L + 0.3V)
Short-Circuit Duration I/O V _L , I/O V _{CC} to GND.....	Continuous
Short-Circuit Duration I/O V _L or I/O V _{CC} to GND Driven from 40mA Source (except MAX3372E and MAX3377E)	Continuous

Continuous Power Dissipation (T_A = +70°C)

8-Pin SOT23 (derate 8.9mW/°C above +70°C).....	714mW
3 x 3 UCSP (derate 4.7mW/°C above +70°C)	379mW
3 x 4 UCSP (derate 6.5mW/°C above +70°C)	579mW
14-Pin TSSOP (derate 9.1mW/°C above +70°C)	727mW
Operating Temperature Range	-40°C to +85°C
Storage Temperature Range	-65°C to +150°C
Lead Temperature (soldering, 10s)	+300°C

Stresses beyond those listed under "Absolute Maximum Ratings" may cause permanent damage to the device. These are stress ratings only, and functional operation of the device at these or any other conditions beyond those indicated in the operational sections of the specifications is not implied. Exposure to absolute maximum rating conditions for extended periods may affect device reliability.

ELECTRICAL CHARACTERISTICS

(V_{CC} = +1.65V to +5.5V, V_L = +1.2V to (V_{CC} + 0.3V), GND = 0, I/O V_{L_} and I/O V_{CC_} unconnected, T_A = T_{MIN} to T_{MAX}, unless otherwise noted. Typical values are at V_{CC} = +3.3V, V_L = +1.8V, T_A = +25°C.) (Notes 1, 2)

PARAMETER	SYMBOL	CONDITIONS	MIN	TYP	MAX	UNITS
POWER SUPPLIES						
V _L Supply Range	V _L		1.2		5.5	V
V _{CC} Supply Range	V _{CC}		1.65		5.50	V
Supply Current from V _{CC}	I _{QVCC}			130	300	µA
Supply Current from V _L	I _{QVL}			16	100	µA
V _{CC} Three-State Output Mode Supply Current	I _{THREE-STATE-VCC}	T _A = +25°C, $\overline{\text{THREE-STATE}} = \text{GND}$		0.03	1	µA
V _L Three-State Output Mode Supply Current	I _{THREE-STATE-VL}	T _A = +25°C, $\overline{\text{THREE-STATE}} = \text{GND}$		0.03	1	µA
Three-State Output Mode Leakage Current I/O V _{L_} and I/O V _{CC_}	I _{THREE-STATE-LKG}	T _A = +25°C, $\overline{\text{THREE-STATE}} = \text{GND}$		0.02	1	µA
$\overline{\text{THREE-STATE}}$ Pin Input Leakage		T _A = +25°C		0.02	1	µA
ESD PROTECTION						
I/O V _{CC} (Note 3)		IEC 1000-4-2 Air-Gap Discharge	±8		kV	
		IEC 1000-4-2 Contact Discharge	±8			
		Human Body Model	±15			
LOGIC-LEVEL THRESHOLDS (MAX3372E/MAX3377E)						
I/O V _{L_} Input-Voltage High	V _{IHL}		V _L - 0.2		V	
I/O V _{L_} Input-Voltage Low	V _{ILL}		0.15		V	

±15kV ESD-Protected, 1μA, 16Mbps, Dual/Quad Low-Voltage Level Translators in UCSP

ELECTRICAL CHARACTERISTICS (continued)

(V_{CC} = +1.65V to +5.5V, V_L = +1.2V to (V_{CC} + 0.3V), GND = 0, I/O V_L and I/O V_{CC} unconnected, T_A = T_{MIN} to T_{MAX}, unless otherwise noted. Typical values are at V_{CC} = +3.3V, V_L = +1.8V, T_A = +25°C.) (Notes 1, 2)

PARAMETER	SYMBOL	CONDITIONS	MIN	TYP	MAX	UNITS
I/O V _{CC} Input-Voltage High	V _{IHC}		V _{CC} - 0.4			V
I/O V _{CC} Input-Voltage Low	V _{I LC}				0.15	V
I/O V _L Output-Voltage High	V _{OHL}	I/O V _L source current = 20μA, I/O V _{CC} ≥ V _{CC} - 0.4V	0.67 × V _L			V
I/O V _L Output-Voltage Low	V _{OLL}	I/O V _L sink current = 20μA, I/O V _{CC} ≤ 0.15V			0.4	V
I/O V _{CC} Output-Voltage High	V _{OHC}	I/O V _{CC} source current = 20μA, I/O V _L ≥ V _L - 0.2V	0.67 × V _{CC}			V
I/O V _{CC} Output-Voltage Low	V _{OLC}	I/O V _{CC} sink current = 20μA, I/O V _L ≤ 0.15V			0.4	V
$\overline{\text{THREE-STATE}}$ Input-Voltage High	V _{IL-THREE-STATE}		V _L - 0.2			V
$\overline{\text{THREE-STATE}}$ Input-Voltage Low	V _{IL-THREE-STATE}				0.15	V
LOGIC-LEVEL THRESHOLDS (MAX3373E–MAX3376E/MAX3378E/MAX3379E and MAX3390E–MAX3393E)						
I/O V _L Input-Voltage High	V _{IHL}		V _L - 0.2			V
I/O V _L Input-Voltage Low	V _{ILL}				0.15	V
I/O V _{CC} Input-Voltage High	V _{IHC}		V _{CC} - 0.4			V
I/O V _{CC} Input-Voltage Low	V _{I LC}				0.15	V
I/O V _L Output-Voltage High	V _{OHL}	I/O V _L source current = 20μA, I/O V _{CC} ≥ V _{CC} - 0.4V	0.67 × V _L			V
I/O V _L Output-Voltage Low	V _{OLL}	I/O V _L sink current = 1mA, I/O V _{CC} ≤ 0.15V			0.4	V
I/O V _{CC} Output-Voltage High	V _{OHC}	I/O V _{CC} source current = 20μA, I/O V _L ≥ V _L - 0.2V	0.67 × V _{CC}			V
I/O V _{CC} Output-Voltage Low	V _{OLC}	I/O V _{CC} sink current = 1mA, I/O V _L ≤ 0.15V			0.4	V
$\overline{\text{THREE-STATE}}$ Input-Voltage High	V _{IH-THREE-STATE}		V _L - 0.2			V
$\overline{\text{THREE-STATE}}$ Input-Voltage Low	V _{IL-THREE-STATE}				0.15	V

MAX3372E-MAX3379E/MAX3390E-MAX3393E

±15kV ESD-Protected, 1µA, 16Mbps, Dual/Quad Low-Voltage Level Translators in UCSP

MAX3372E-MAX3379E/MAX3390E-MAX3393E

TIMING CHARACTERISTICS

(VCC = +1.65V to +5.5V, VL = +1.2V to (VCC + 0.3V), GND = 0, RLOAD = 1MΩ, I/O test signal of Figure 1, TA = TMIN to TMAX, unless otherwise noted. Typical values are at VCC = +3.3V, VL = +1.8V, TA = +25°C, unless otherwise noted.) (Notes 1, 2)

PARAMETER	SYMBOL	CONDITIONS	MIN	TYP	MAX	UNITS
MAX3372E/MAX3377E (CLOAD = 50pF)						
I/O VCC_ Rise Time (Note 4)	tRVCC			1100		ns
I/O VCC_ Fall Time (Note 5)	tFVCC			1000		ns
I/O VL_ Rise Time (Note 4)	tRVL			600		ns
I/O VL_ Fall Time (Note 5)	tFVL			1100		ns
Propagation Delay	I/OVL-VCC	Driving I/O VL_			1.6	µs
	I/OVCC-VL	Driving I/O VCC_			1.6	
Channel-to-Channel Skew	tSKEW	Each translator equally loaded			500	ns
Maximum Data Rate		CL = 25pF	230			kbps
MAX3373E-MAX3376E/MAX3378E/MAX3379E and MAX3390E-MAX3393E (CLOAD = 15pF, Driver Output Impedance ≤ 50Ω)						
+1.2V ≤ VL ≤ VCC ≤ +5.5V						
I/O VCC_ Rise Time (Note 4)	tRVCC			7	25	ns
		Open-drain driving		170	400	
I/O VCC_ Fall Time (Note 5)	tFVCC			6	37	ns
		Open-drain driving		20	50	
I/O VL_ Rise Time (Note 4)	tRVL			8	30	ns
		Open-drain driving		180	400	
I/O VL_ Fall Time (Note 5)	tLFV			3	30	ns
		Open-drain driving		30	60	
Propagation Delay	I/OVL-VCC	Driving I/O VL_		5	30	ns
			Open-drain driving		210	
	I/OVCC-VL	Driving I/O VCC_		4	30	
			Open-drain driving		190	
Channel-to-Channel Skew	tSKEW	Each translator equally loaded			20	ns
			Open-drain driving			
Maximum Data Rate			8			Mbps
		Open-drain driving	500			kbps

±15kV ESD-Protected, 1μA, 16Mbps, Dual/Quad Low-Voltage Level Translators in UCSP

TIMING CHARACTERISTICS (continued)

(V_{CC} = +1.65V to +5.5V, V_L = +1.2V to (V_{CC} + 0.3V), GND = 0, R_{LOAD} = 1MΩ, I/O test signal of Figure 1, T_A = T_{MIN} to T_{MAX}, unless otherwise noted. Typical values are at V_{CC} = +3.3V, V_L = +1.8V, T_A = +25°C, unless otherwise noted.) (Notes 1, 2)

PARAMETER	SYMBOL	CONDITIONS	MIN	TYP	MAX	UNITS
+1.2V ≤ V_L ≤ V_{CC} ≤ +3.3V						
I/O V _{CC} _ Rise Time (Note 4)	t _{RVCC}				25	ns
I/O V _{CC} _ Fall Time (Note 5)	t _{FVCC}				30	ns
I/O V _L _ Rise Time (Note 4)	t _{RVL}				30	ns
I/O V _L _ Fall Time (Note 5)	t _{FVL}				30	ns
Propagation Delay	I/O _{VL} -V _{CC}	Driving I/O V _L _			20	ns
	I/O _{VCC} -V _L	Driving I/O V _{CC} _			20	
Channel-to-Channel Skew	t _{SKEW}	Each translator equally loaded			10	ns
Maximum Data Rate			10			Mbps
+2.5V ≤ V_L ≤ V_{CC} ≤ +3.3V						
I/O V _{CC} _ Rise Time (Note 4)	t _{RVCC}				15	ns
I/O V _{CC} _ Fall Time (Note 5)	t _{FVCC}				15	ns
I/O V _L _ Rise Time (Note 4)	t _{RVL}				15	ns
I/O V _L _ Fall Time (Note 5)	t _{FVL}				15	ns
Propagation Delay	I/O _{VL} -V _{CC}	Driving I/O V _L _			15	ns
	I/O _{VCC} -V _L	Driving I/O V _{CC} _			15	
Channel-to-Channel Skew	t _{SKEW}	Each translator equally loaded			10	ns
Maximum Data Rate			16			Mbps
+1.8V ≤ V_L ≤ V_{CC} ≤ +2.5V						
I/O V _{CC} _ Rise Time (Note 4)	t _{RVCC}				15	ns
I/O V _{CC} _ Fall Time (Note 5)	t _{FVCC}				15	ns
I/O V _L _ Rise Time (Note 4)	t _{RVL}				15	ns
I/O V _L _ Fall Time (Note 5)	t _{FVL}				15	ns
Propagation Delay	I/O _{VL} -V _{CC}	Driving I/O V _L _			15	ns
	I/O _{VCC} -V _L	Driving I/O V _{CC} _			15	
Channel-to-Channel Skew	t _{SKEW}	Each translator equally loaded			10	ns
Maximum Data Rate			16			Mbps

Note 1: All units are 100% production tested at T_A = +25°C. Limits over the operating temperature range are guaranteed by design and not production tested.

Note 2: For normal operation, ensure V_L < (V_{CC} + 0.3V). During power-up, V_L > (V_{CC} + 0.3V) will not damage the device.

Note 3: To ensure maximum ESD protection, place a 1μF capacitor between V_{CC} and GND. See *Applications Circuits*.

Note 4: 10% to 90%

Note 5: 90% to 10%

±15kV ESD-Protected, 1µA, 16Mbps, Dual/Quad Low-Voltage Level Translators in UCSP

Typical Operating Characteristics

($R_{LOAD} = 1M\Omega$, $T_A = +25^\circ C$, unless otherwise noted. All 230kbps TOCs apply to MAX3372E/MAX3377E only. All 8Mbps and 500kbps TOCs apply to MAX3373E-MAX3376E/MAX3378E/MAX3379E and MAX3390E-MAX3393E only.)

V_L SUPPLY CURRENT vs. SUPPLY VOLTAGE
(DRIVING I/O V_L , $V_{CC} = +3.3V$, $V_L = +1.8V$)

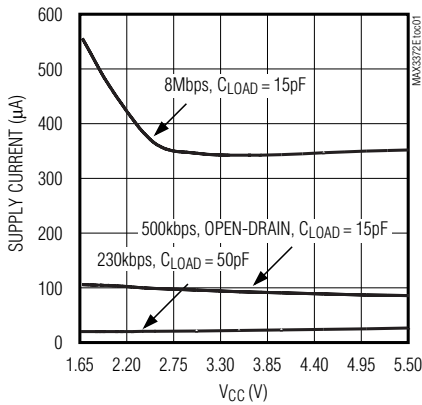

V_{CC} SUPPLY CURRENT vs. SUPPLY VOLTAGE
(DRIVING I/O V_L , $V_{CC} = +3.3V$, $V_L = +1.8V$)

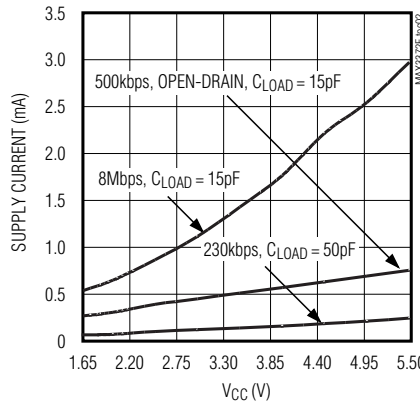

V_L SUPPLY CURRENT vs. TEMPERATURE
(DRIVING I/O V_{CC} , $V_{CC} = +3.3V$, $V_L = +1.8V$)

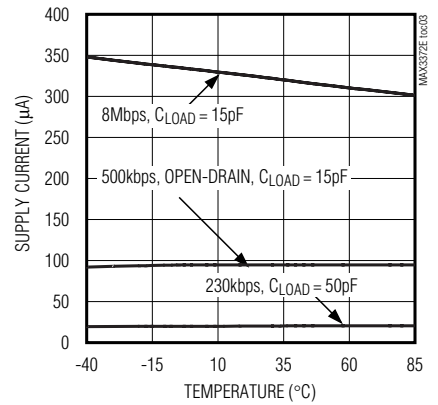

V_{CC} SUPPLY CURRENT vs. TEMPERATURE
(DRIVING I/O V_{CC} , $V_{CC} = +3.3V$, $V_L = +1.8V$)

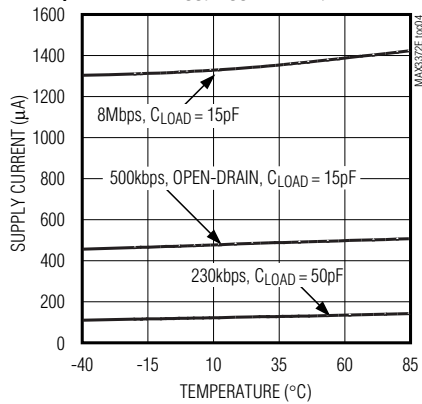

V_L SUPPLY CURRENT vs. CAPACITIVE LOAD
(DRIVING I/O V_L , $V_{CC} = +3.3V$, $V_L = +1.8V$)

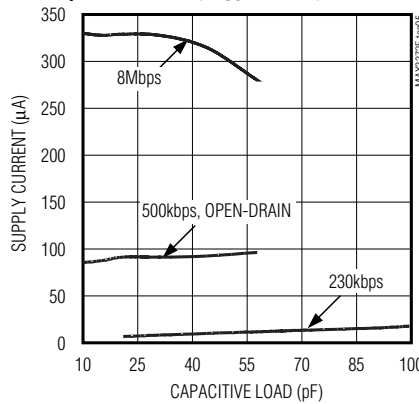

V_{CC} SUPPLY CURRENT vs. CAPACITIVE LOAD
(DRIVING I/O V_L , $V_{CC} = +3.3V$, $V_L = +1.8V$)

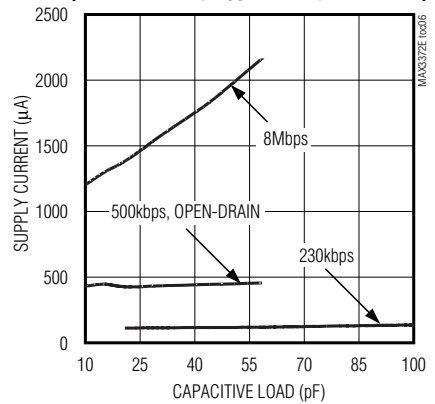

RISE/FALL TIME vs. CAPACITIVE LOAD
(DRIVING I/O V_L , $V_{CC} = +3.3V$, $V_L = +1.8V$)

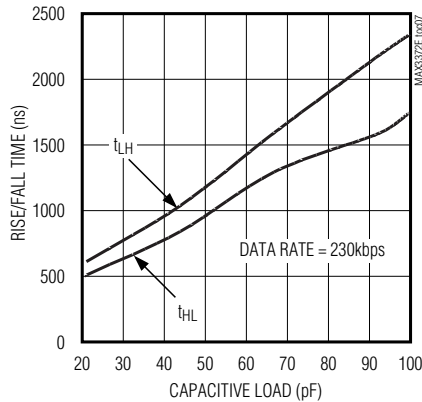

RISE/FALL TIME vs. CAPACITIVE LOAD
(DRIVING I/O V_L , $V_{CC} = +3.3V$, $V_L = +1.8V$)

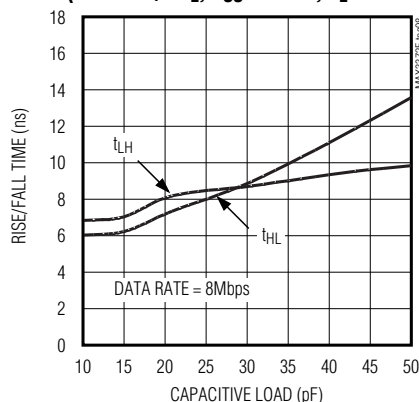

RISE/FALL TIME vs. CAPACITIVE LOAD
(DRIVING I/O V_L , $V_{CC} = +3.3V$, $V_L = +1.8V$)

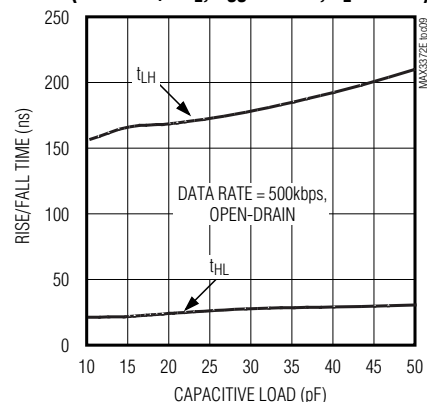

±15kV ESD-Protected, 1µA, 16Mbps, Dual/Quad Low-Voltage Level Translators in UCSP

Typical Operating Characteristics (continued)

($R_{LOAD} = 1M\Omega$, $T_A = +25^\circ C$, unless otherwise noted. All 230kbps TOCs apply to MAX3372E/MAX3377E only. All 8Mbps and 500kbps TOCs apply to MAX3373E-MAX3376E/MAX3378E/MAX3379E and MAX3390E-MAX3393E only.)

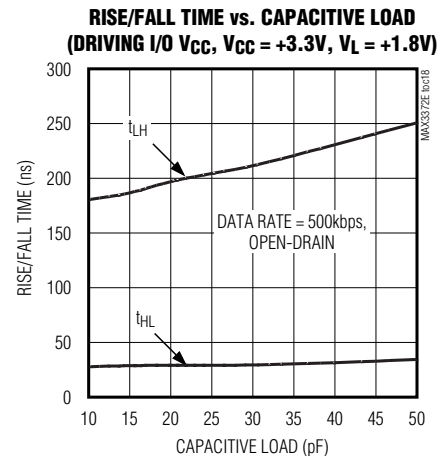
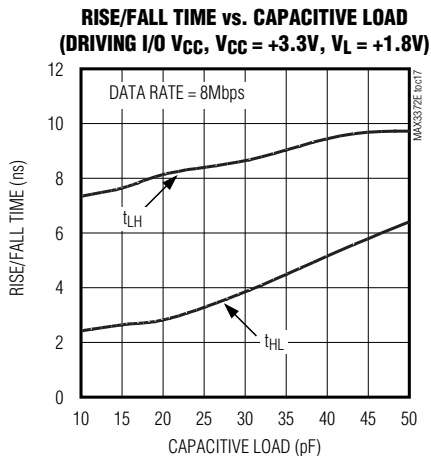
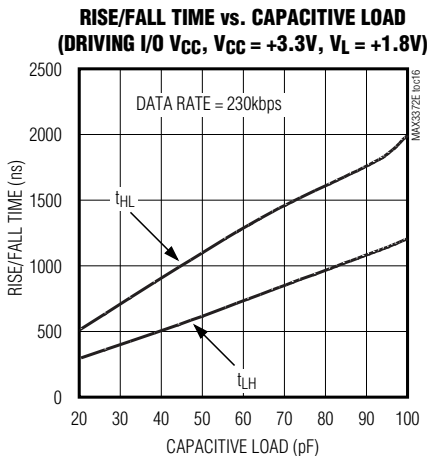
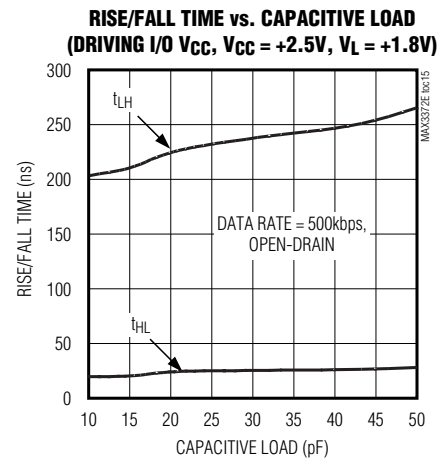
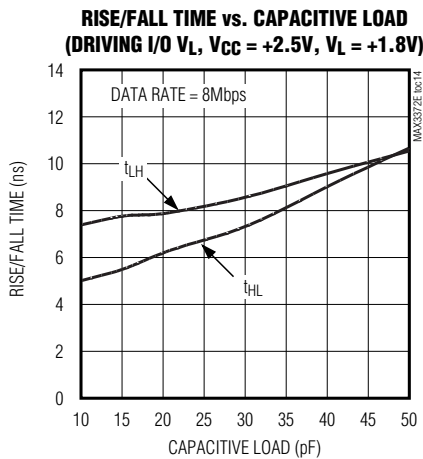
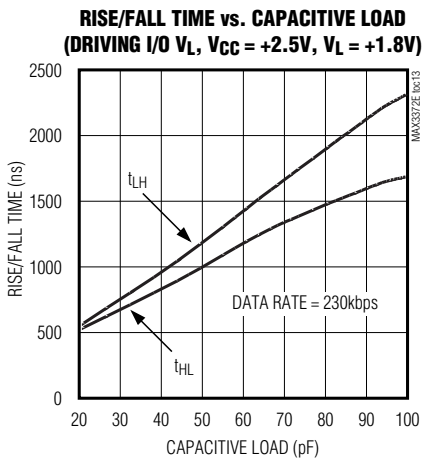
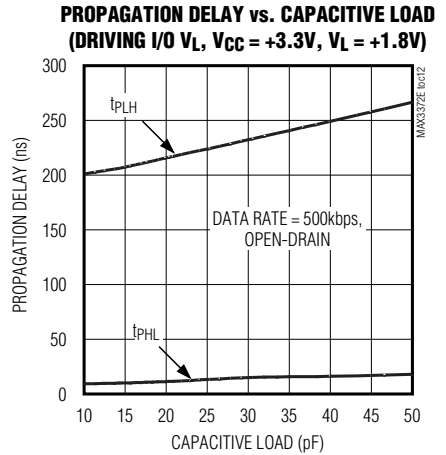
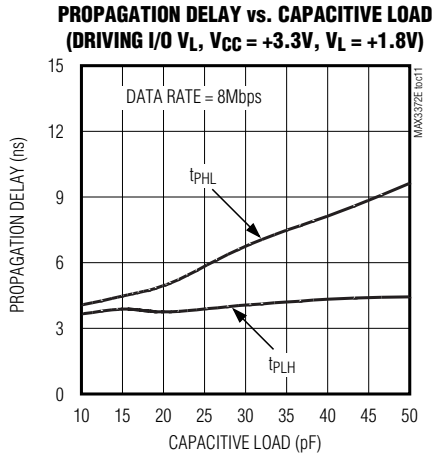
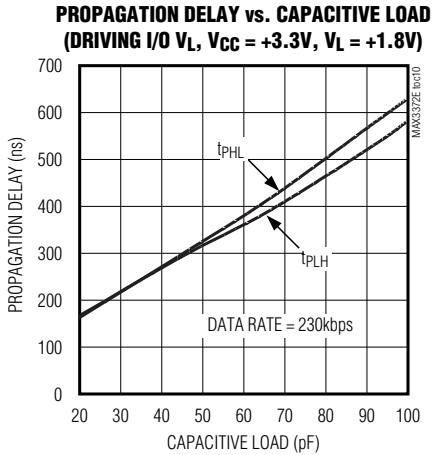

±15kV ESD-Protected, 1µA, 16Mbps, Dual/Quad Low-Voltage Level Translators in UCSP

Typical Operating Characteristics (continued)

($R_{LOAD} = 1M\Omega$, $T_A = +25^\circ C$, unless otherwise noted. All 230kbps TOCs apply to MAX3372E/MAX3377E only. All 8Mbps and 500kbps TOCs apply to MAX3373E-MAX3376E/MAX3378E/MAX3379E and MAX3390E-MAX3393E only.)

PROPAGATION DELAY vs. CAPACITIVE LOAD
(DRIVING I/O V_{CC} , $V_{CC} = +3.3V$, $V_L = +1.8V$)

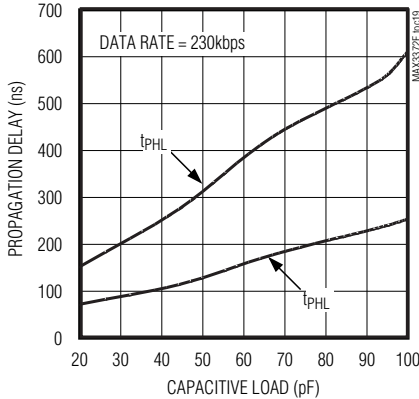

PROPAGATION DELAY vs. CAPACITIVE LOAD
(DRIVING I/O V_{CC} , $V_{CC} = +3.3V$, $V_L = +1.8V$)

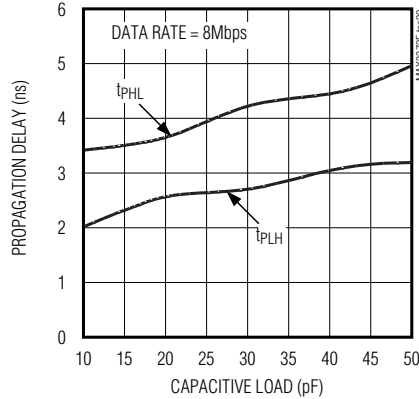

PROPAGATION DELAY vs. CAPACITIVE LOAD
(DRIVING I/O V_{CC} , $V_{CC} = +3.3V$, $V_L = +1.8V$)

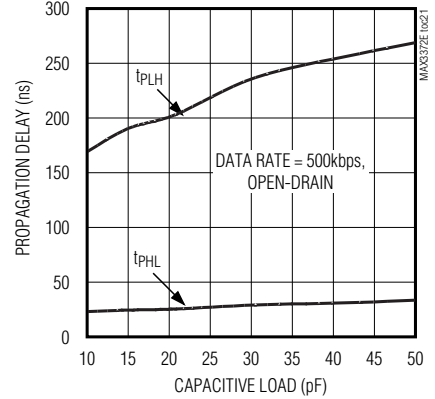

RISE/FALL TIME vs. CAPACITIVE LOAD
(DRIVING I/O V_{CC} , $V_{CC} = +2.5V$, $V_L = +1.8V$)

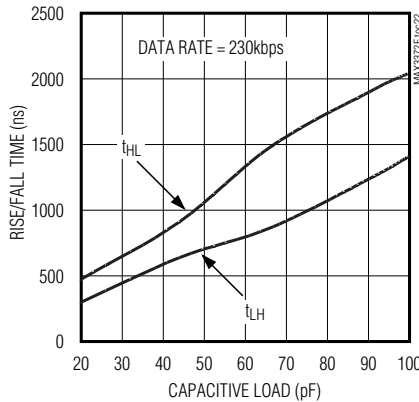

RISE/FALL TIME vs. CAPACITIVE LOAD
(DRIVING I/O V_{CC} , $V_{CC} = +2.5V$, $V_L = +1.8V$)

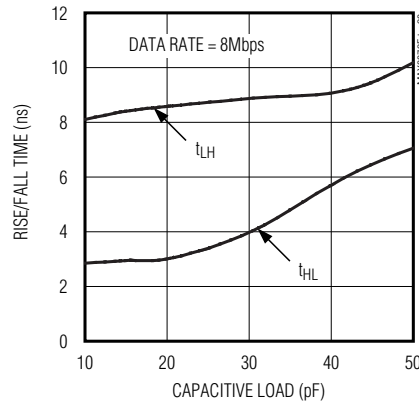

RISE/FALL TIME vs. CAPACITIVE LOAD
(DRIVING I/O V_{CC} , $V_{CC} = +2.5V$, $V_L = +1.8V$)

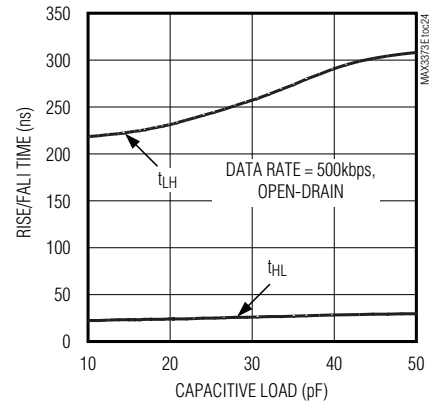

RAIL-TO-RAIL DRIVING
(DRIVING I/O V_L , $V_{CC} = +3.3V$, $V_L = +1.8V$,
 $C_{LOAD} = 50pF$, DATA RATE = 230kbps)

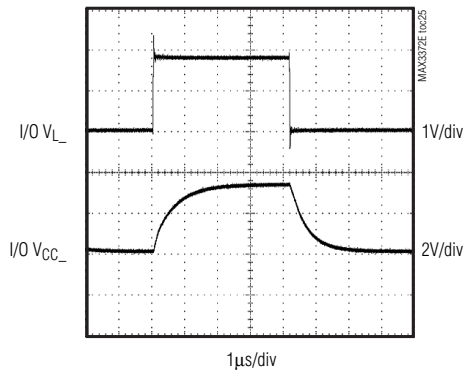

RAIL-TO-RAIL DRIVING
(DRIVING I/O V_L , $V_{CC} = +3.3V$, $V_L = +1.8V$,
 $C_{LOAD} = 15pF$, DATA RATE = 8Mbps)

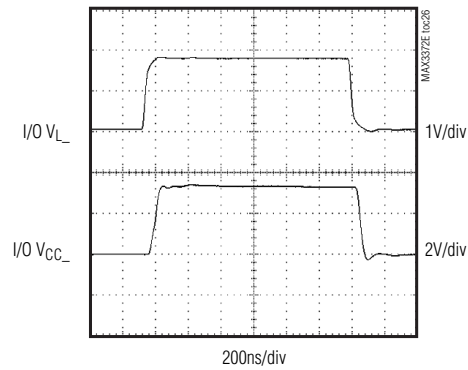

±15kV ESD-Protected, 1µA, 16Mbps, Dual/Quad Low-Voltage Level Translators in UCSP

Typical Operating Characteristics (continued)

($R_{LOAD} = 1M\Omega$, $T_A = +25^\circ C$, unless otherwise noted. All 230kbps TOCs apply to MAX3372E/MAX3377E only. All 8Mbps and 500kbps TOCs apply to MAX3373E–MAX3376E/MAX3378E/MAX3379E and MAX3390E–MAX3393E only.)

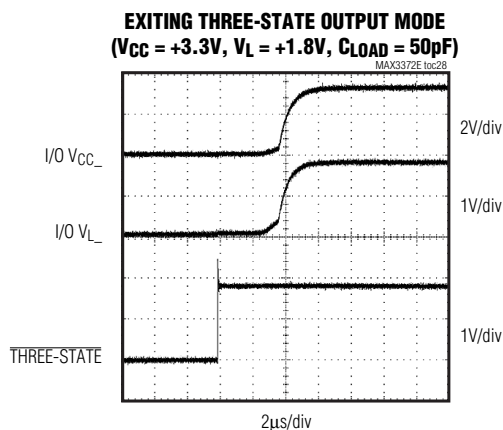
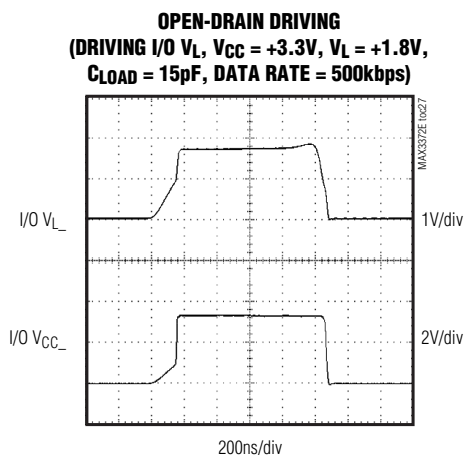

Pin Description

3 x 4 UCSP	PIN			NAME	FUNCTION
	TSSOP	SOT23-8	3 x 3 UCSP		
A1	2	5	C2	I/O V_{L1}	Input/Output 1. Referenced to V_L . (Note 6)
A2	3	4	C3	I/O V_{L2}	Input/Output 2. Referenced to V_L . (Note 6)
A3	4	—	—	I/O V_{L3}	Input/Output 3. Referenced to V_L . (Note 6)
A4	5	—	—	I/O V_{L4}	Input/Output 4. Referenced to V_L . (Note 6)
B1	14	7	A1	V_{CC}	V_{CC} Input Voltage $+1.65V \leq V_{CC} \leq +5.5V$.
B2	1	3	C1	V_L	Logic Input Voltage $+1.2V \leq V_L \leq (V_{CC} + 0.3V)$
B3	8	6	B1	$\overline{\text{THREE-STATE}}$	Three-State Output Mode Enable. Pull $\overline{\text{THREE-STATE}}$ low to place device in three-state output mode. I/O V_{CC} and I/O V_L are high impedance in three-state output mode. NOTE: Logic referenced to V_L (for logic thresholds see the <i>Electrical Characteristics</i> table).
B4	7	2	B3	GND	Ground
C1	13	8	A2	I/O V_{CC1}	Input/Output 1. Referenced to V_{CC} . (Note 6)
C2	12	1	A3	I/O V_{CC2}	Input/Output 2. Referenced to V_{CC} . (Note 6)
C3	11	—	—	I/O V_{CC3}	Input/Output 3. Referenced to V_{CC} . (Note 6)
C4	10	—	—	I/O V_{CC4}	Input/Output 4. Referenced to V_{CC} . (Note 6)
—	6, 9	—	B2	N.C.	No Connection. Not internally connected.

Note 6: For unidirectional devices (MAX3374E/MAX3375E/MAX3376E/MAX3379E and MAX3390E–MAX3393E) see *Pin Configurations* for input/output configurations.

±15kV ESD-Protected, 1µA, 16Mbps, Dual/Quad Low-Voltage Level Translators in UCSP

Detailed Description

The MAX3372E-MAX3379E and MAX3390E-MAX3393E ESD-protected level translators provide the level shifting necessary to allow data transfer in a multivoltage system. Externally applied voltages, V_{CC} and V_L , set the logic levels on either side of the device. A low-voltage logic signal present on the V_L side of the device appears as a high-voltage logic signal on the V_{CC} side of the device, and vice-versa. The MAX3374E/MAX3375E/MAX3376E/MAX3379E and MAX3390E-MAX3393E unidirectional level translators level shift data in one direction ($V_L \rightarrow V_{CC}$ or $V_{CC} \rightarrow V_L$) on any single data line. The MAX3372E/MAX3373E and MAX3377E/MAX3378E bidirectional level translators utilize a transmission-gate-based design (see Figure 2) to allow data translation in either direction ($V_L \leftrightarrow V_{CC}$) on any single data line. The MAX3372E-MAX3379E and MAX3390E-MAX3393E

accept V_L from +1.2V to +5.5V and V_{CC} from +1.65V to +5.5V, making them ideal for data transfer between low-voltage ASICs/PLDs and higher voltage systems.

All devices in the MAX3372E-MAX3379E, MAX3390E-MAX3393E family feature a three-state output mode that reduces supply current to less than 1µA, thermal short-circuit protection, and ±15kV ESD protection on the V_{CC} side for greater protection in applications that route signals externally. The MAX3372E/MAX3377E operate at a guaranteed data rate of 230kbps. Slew-rate limiting reduces EMI emissions in all 230kbps devices. The MAX3373E-MAX3376E/MAX3378E/MAX3379E and MAX3390E-MAX3393E operate at a guaranteed data rate of 8Mbps over the entire specified operating voltage range. Within specific voltage domains, higher data rates are possible. (See the *Timing Characteristics*.)

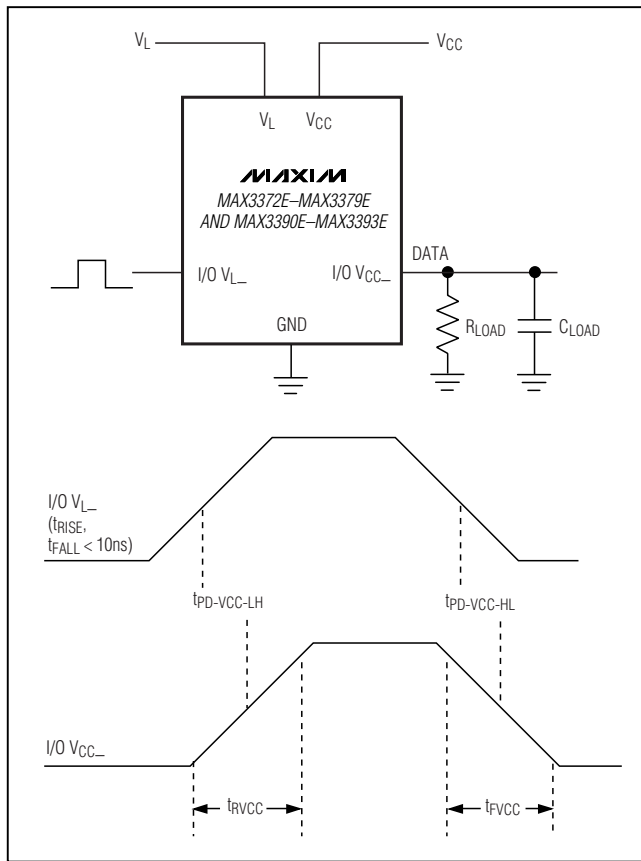

Figure 1a. Rail-to-Rail Driving I/O V_L

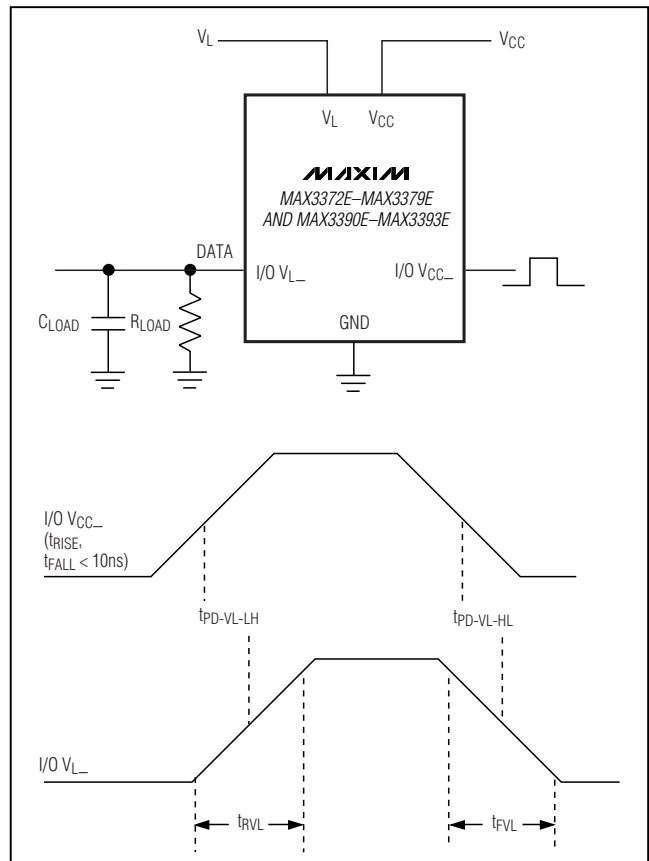

Figure 1b. Rail-to-Rail Driving I/O V_{CC}

±15kV ESD-Protected, 1µA, 16Mbps, Dual/Quad Low-Voltage Level Translators in UCSP

Level Translation

For proper operation ensure that $+1.65V \leq V_{CC} \leq +5.5V$, $+1.2V \leq V_L \leq +5.5V$, and $V_L \leq (V_{CC} + 0.3V)$. During power-up sequencing, $V_L \geq (V_{CC} + 0.3V)$ will not damage the device. During power-supply sequencing, when V_{CC} is floating and V_L is powering up, a current may be sourced, yet the device will not latch up. The speed-up circuitry limits the maximum data rate for devices in the MAX3372E-MAX3379E, MAX3390E-MAX3393E family to 16Mbps. The maximum data rate also depends heavily on the load capacitance (see the *Typical Operating Characteristics*), output impedance of the driver, and the operational voltage range (see the *Timing Characteristics*).

Speed-Up Circuitry

The MAX3373E-MAX3376E/MAX3378E/MAX3379E and MAX3390E-MAX3393E feature a one-shot generator that decreases the rise time of the output. When triggered, MOSFETs PU1 and PU2 turn on for a short time to pull up

I/O $V_{L_}$ and I/O $V_{CC_}$ to their respective supplies (see Figure 2b). This greatly reduces the rise time and propagation delay for the low-to-high transition. The scope photo of Rail-to-Rail Driving for 8Mbps Operation in the *Typical Operating Characteristics* shows the speed-up circuitry in operation.

Rise-Time Accelerators

The MAX3373E-MAX3376E/MAX3378E/MAX3379E and the MAX3390E-MAX3393E have internal rise-time accelerators allowing operation up to 16Mbps. The rise-time accelerators are present on both sides of the device and act to speed up the rise time of the input and output of the device, regardless of the direction of the data. The triggering mechanism for these accelerators is both level and edge sensitive. To prevent false triggering of the rise-time accelerators, signal fall times of less than 20ns/V are recommended for both the inputs and outputs of the device. Under less noisy conditions, longer signal fall times may be acceptable.

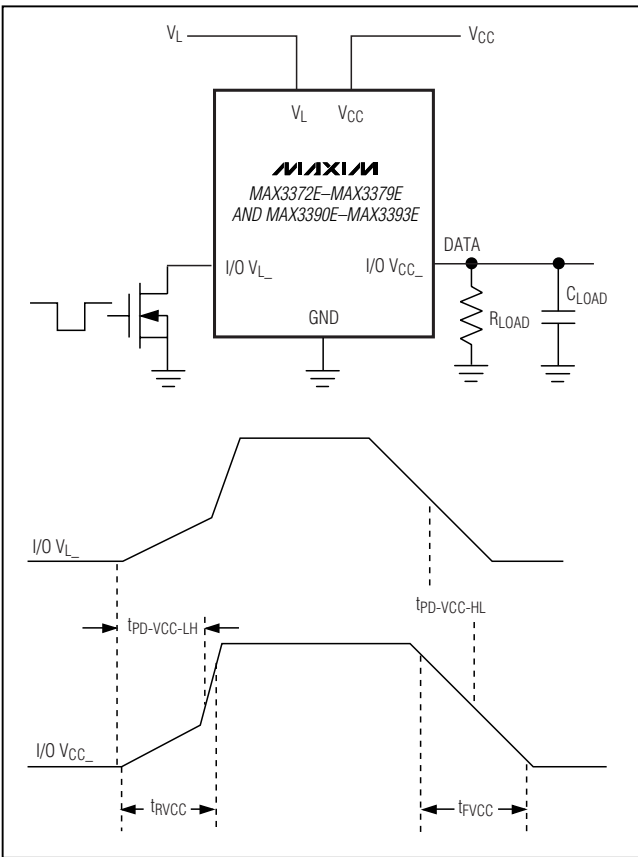

Figure 1c. Open-Drain Driving I/O V_{CC}

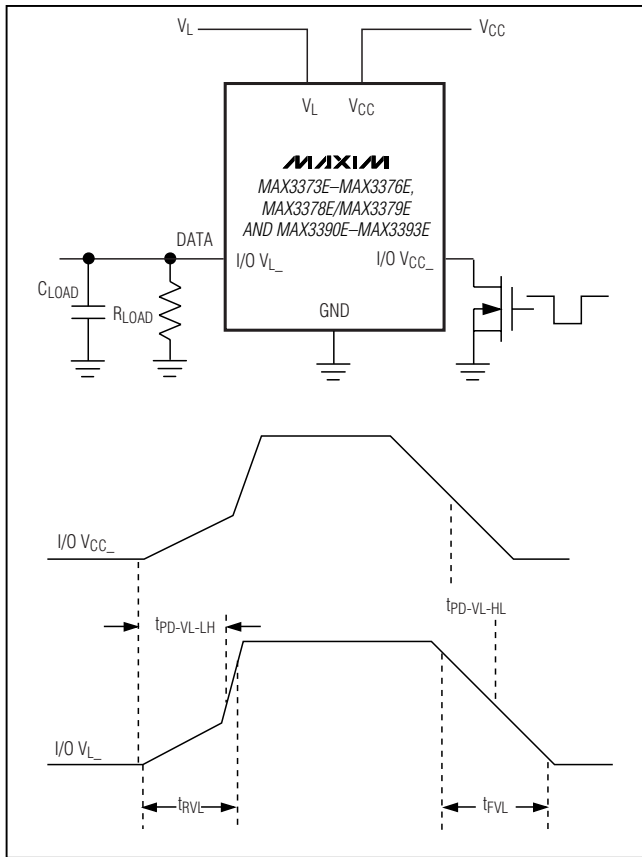

Figure 1d. Open-Drain Driving I/O V_L

±15kV ESD-Protected, 1µA, 16Mbps, Dual/Quad Low-Voltage Level Translators in UCSP

Three-State Output Mode

Pull `THREE-STATE` low to place the MAX3372E-MAX3379E and MAX3390E-MAX3393E in three-state output mode. Connect `THREE-STATE` to V_L (logic high) for normal operation. Activating the three-state output mode disconnects the internal $10k\Omega$ pullup resistors on the I/O V_{CC} and I/O V_L lines. This forces the I/O lines to a high-impedance state, and decreases the supply current to less than $1\mu A$. The high-impedance I/O lines in three-state output mode allow for use in a multidrop network. When in three-state output mode, do not allow the voltage

at I/O V_L to exceed $(V_L + 0.3V)$, or the voltage at I/O V_{CC} to exceed $(V_{CC} + 0.3V)$.

Thermal Short-Circuit Protection

Thermal overload detection protects the MAX3372E-MAX3379E and MAX3390E-MAX3393E from short-circuit fault conditions. In the event of a short-circuit fault, when the junction temperature (T_J) reaches $+152^\circ C$, a thermal sensor signals the three-state output mode logic to force the device into three-state output mode. When T_J has cooled to $+142^\circ C$, normal operation resumes.

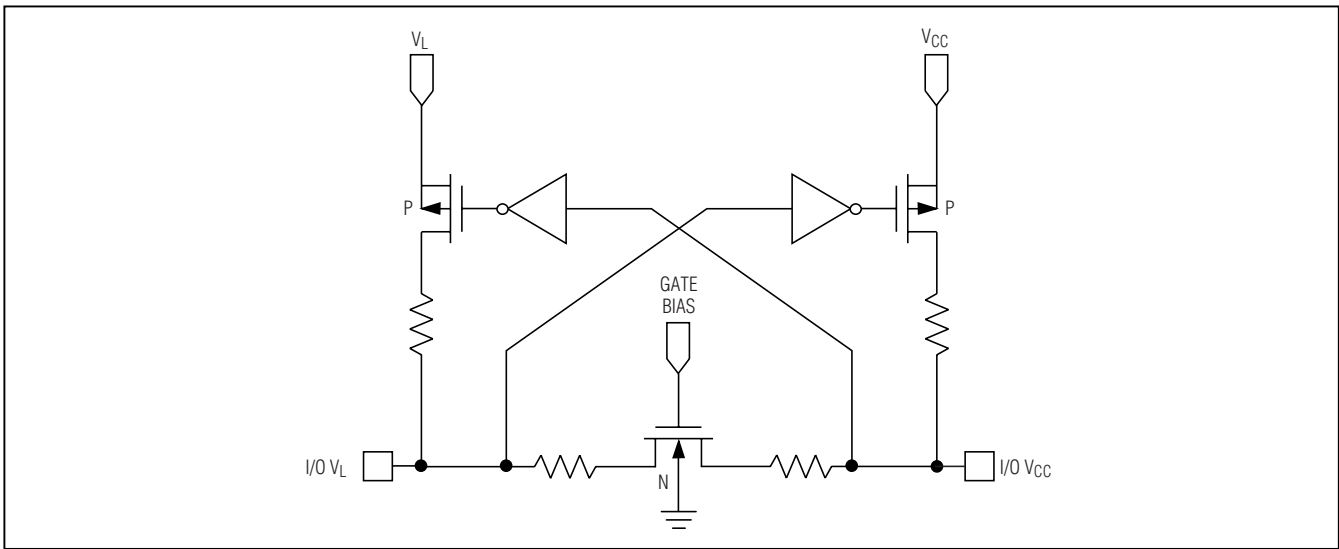

Figure 2a. Functional Diagram, MAX3372E/MAX3377E (1 I/O line)

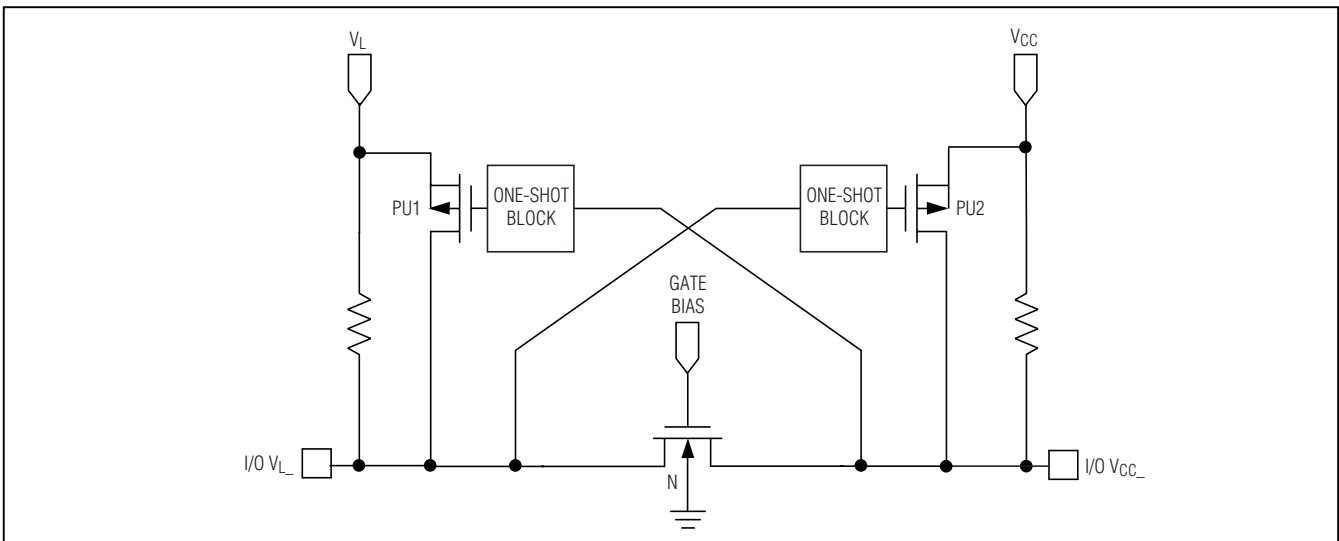

Figure 2b. Functional Diagram, MAX3373E/MAX3378E (1 I/O line)

±15kV ESD-Protected, 1µA, 16Mbps, Dual/Quad Low-Voltage Level Translators in UCSP

±15kV ESD Protection

As with all Maxim devices, ESD-protection structures are incorporated on all pins to protect against electrostatic discharges encountered during handling and assembly. The I/O VCC lines have extra protection against static electricity. Maxim's engineers have developed state-of-the-art structures to protect these pins against ESD of ±15kV without damage. The ESD structures withstand high ESD in all states: normal operation, three-state output mode, and powered down. After an ESD event, Maxim's E versions keep working without latchup, whereas competing products can latch and must be powered down to remove latchup.

ESD protection can be tested in various ways. The I/O VCC lines of this product family are characterized for protection to the following limits:

- 1) ±15kV using the Human Body Model
- 2) ±8kV using the Contact Discharge method specified in IEC 1000-4-2
- 3) ±10kV using IEC 1000-4-2's Air-Gap Discharge method

ESD Test Conditions

ESD performance depends on a variety of conditions. Contact Maxim for a reliability report that documents test setup, test methodology, and test results.

Human Body Model

Figure 3a shows the Human Body Model and Figure 3b shows the current waveform it generates when discharged into a low impedance. This model consists of a 100pF capacitor charged to the ESD voltage of interest, which is then discharged into the test device through a 1.5kΩ resistor.

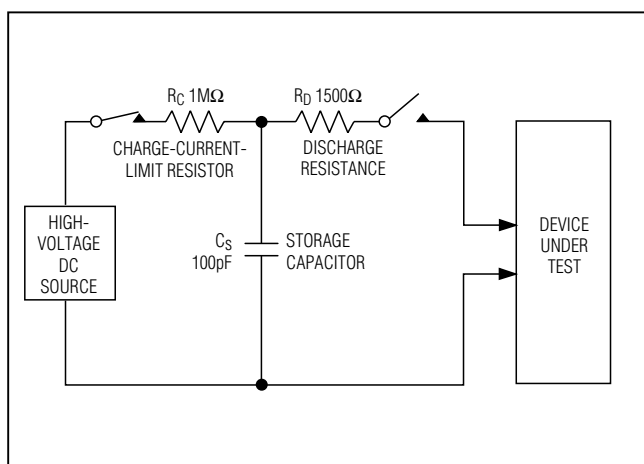

Figure 3a. Human Body ESD Test Model

IEC 1000-4-2

The IEC 1000-4-2 standard covers ESD testing and performance of finished equipment; it does not specifically refer to integrated circuits. The MAX3372E-MAX3379E and MAX3390E-MAX3393E help to design equipment that meets Level 3 of IEC 1000-4-2, without the need for additional ESD-protection components.

The major difference between tests done using the Human Body Model and IEC 1000-4-2 is higher peak current in IEC 1000-4-2, because series resistance is lower in the IEC 1000-4-2 model. Hence, the ESD withstand voltage measured to IEC 1000-4-2 is generally lower than that measured using the Human Body Model. Figure 4a shows the IEC 1000-4-2 model, and Figure 4b shows the current waveform for the ±8kV, IEC 1000-4-2, Level 4, ESD contact-discharge test.

The air-gap test involves approaching the device with a charged probe. The contact-discharge method connects the probe to the device before the probe is energized.

Machine Model

The Machine Model for ESD tests all pins using a 200pF storage capacitor and zero discharge resistance. Its objective is to emulate the stress caused by contact that occurs with handling and assembly during manufacturing. Of course, all pins require this protection during manufacturing, not just inputs and outputs. Therefore, after PC board assembly, the Machine Model is less relevant to I/O ports.

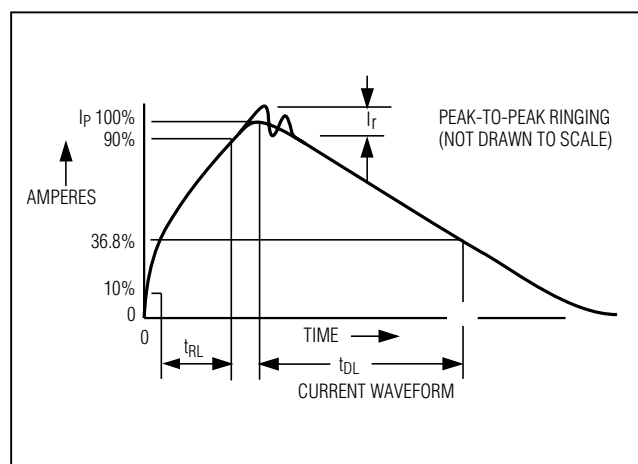

Figure 3b. Human Body Current Waveform

±15kV ESD-Protected, 1µA, 16Mbps, Dual/Quad Low-Voltage Level Translators in UCSP

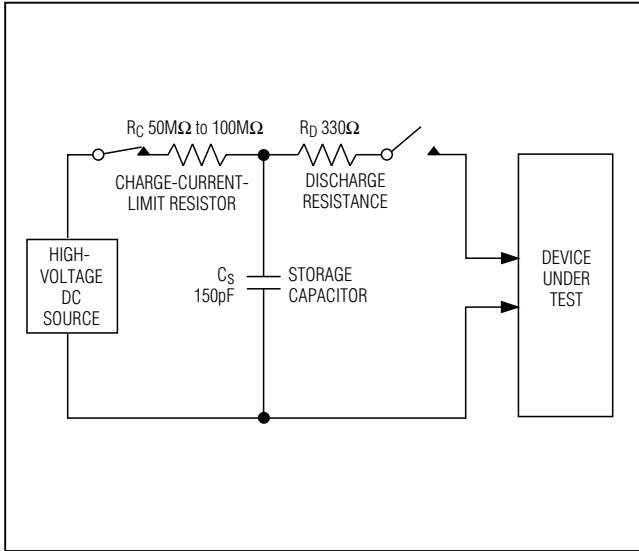

Figure 4a. IEC 1000-4-2 ESD Test Model

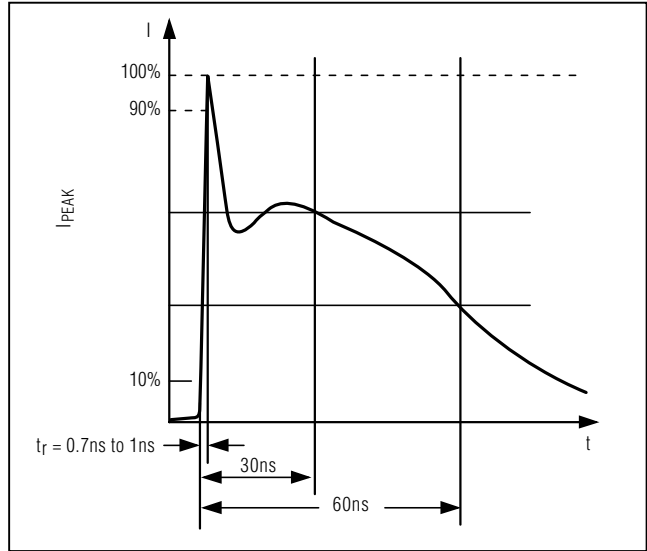

Figure 4b. IEC 1000-4-2 ESD Generator Current Waveform

Applications Information

Power-Supply Decoupling

To reduce ripple and the chance of transmitting incorrect data, bypass V_L and V_{CC} to ground with a 0.1µF capacitor. See the *Typical Operating Circuit*. To ensure full ±15kV ESD protection, bypass V_{CC} to ground with a 1µF capacitor. Place all capacitors as close to the power-supply inputs as possible.

I²C Level Translation

The MAX3373E-MAX3376E, MAX3378E/MAX3379E and MAX3390E-MAX3393E level-shift the data present on the I/O lines between +1.2V and +5.5V, making them ideal for level translation between a low-voltage

ASIC and an I²C device. A typical application involves interfacing a low-voltage microprocessor to a 3V or 5V D/A converter, such as the MAX517.

Push-Pull vs. Open-Drive Driving

All devices in the MAX3372E-MAX3379E and MAX3390E-MAX3393E family may be driven in a push-pull configuration. The MAX3373E-MAX3376E/MAX3378E/MAX3379E and MAX3390E-MAX3393E include internal 10kΩ resistors that pull up I/O V_L and I/O V_{CC} to their respective power supplies, allowing operation of the I/O lines with open-drain devices. See the *Timing Characteristics* for maximum data rates when using open-drain drivers.

Typical Operating Circuit

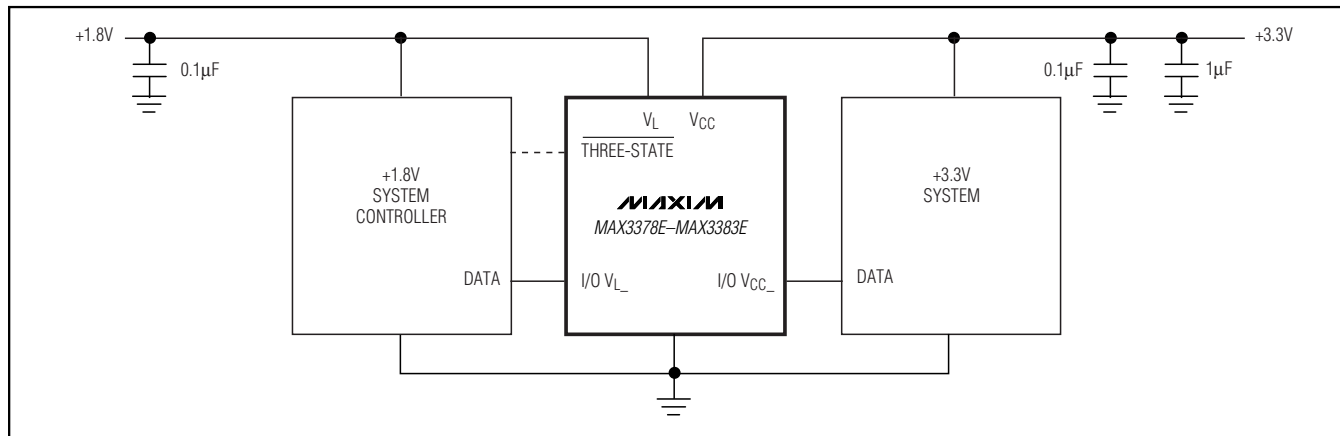

±15kV ESD-Protected, 1µA, 16Mbps, Dual/Quad Low-Voltage Level Translators in UCSP

Applications Circuits

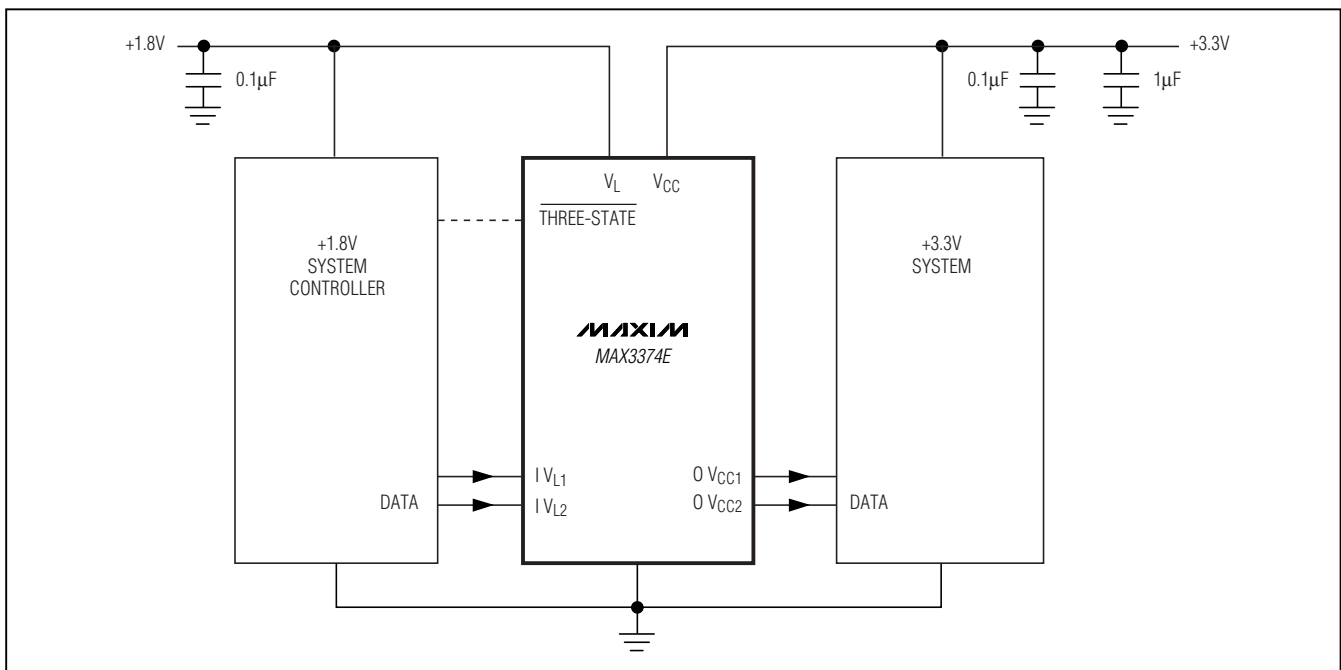
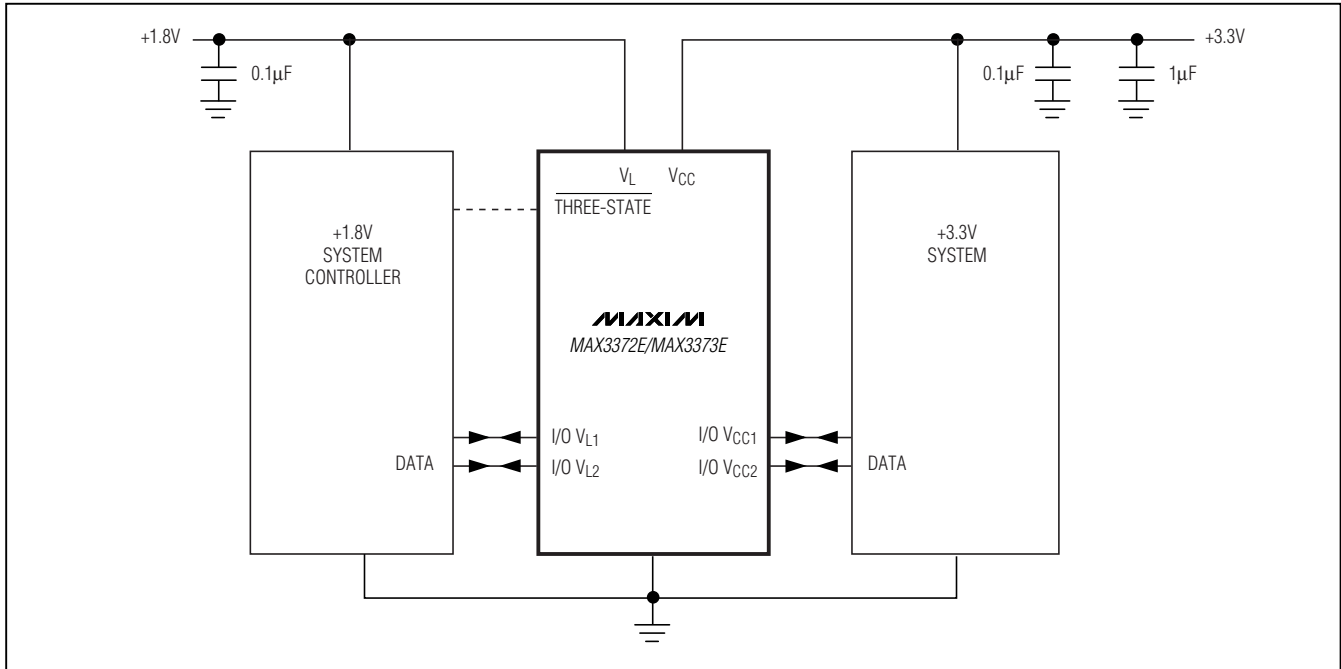

MAX3372E-MAX3379E/MAX33390E-MAX33393E

±15kV ESD-Protected, 1µA, 16Mbps, Dual/Quad Low-Voltage Level Translators in UCSP

Applications Circuits (continued)

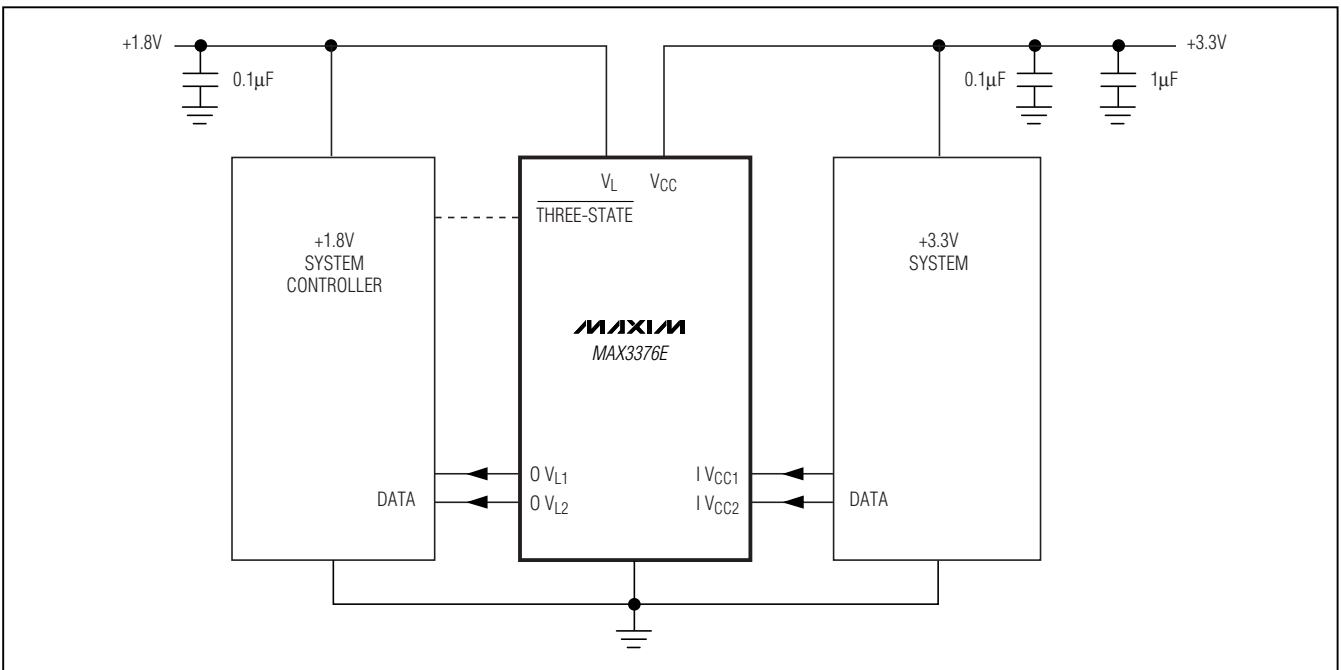
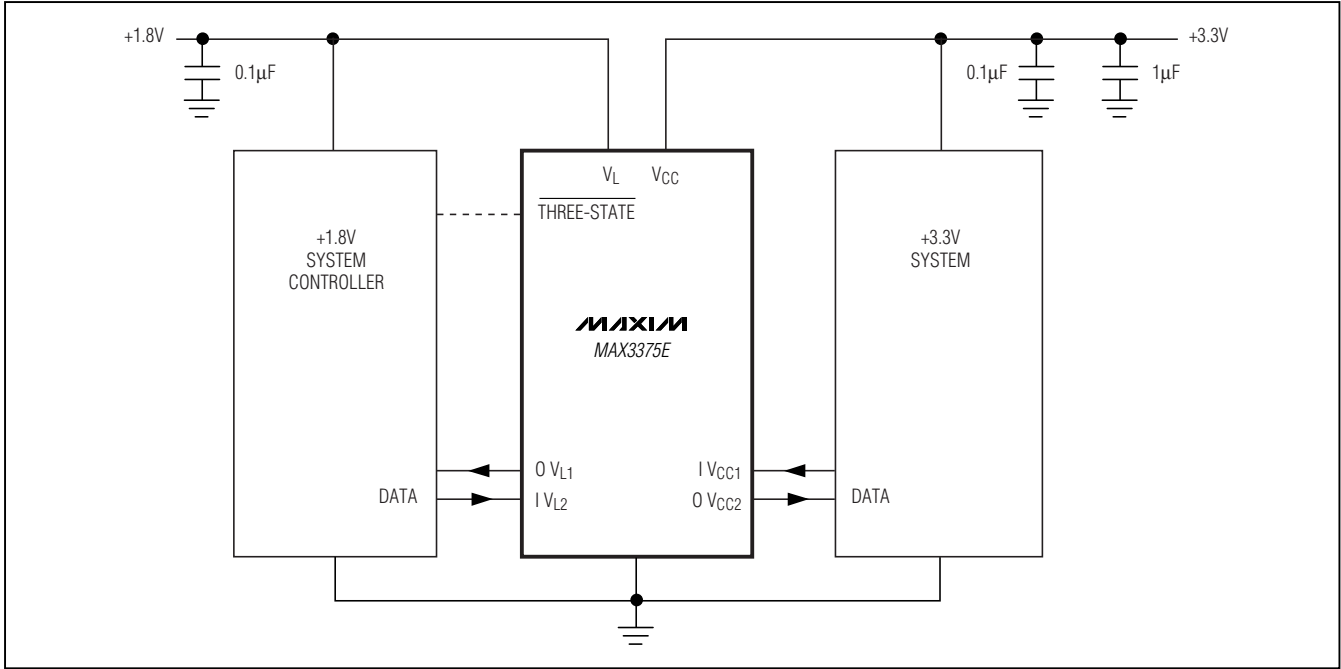

±15kV ESD-Protected, 1µA, 16Mbps, Dual/Quad Low-Voltage Level Translators in UCSP

Applications Circuits (continued)

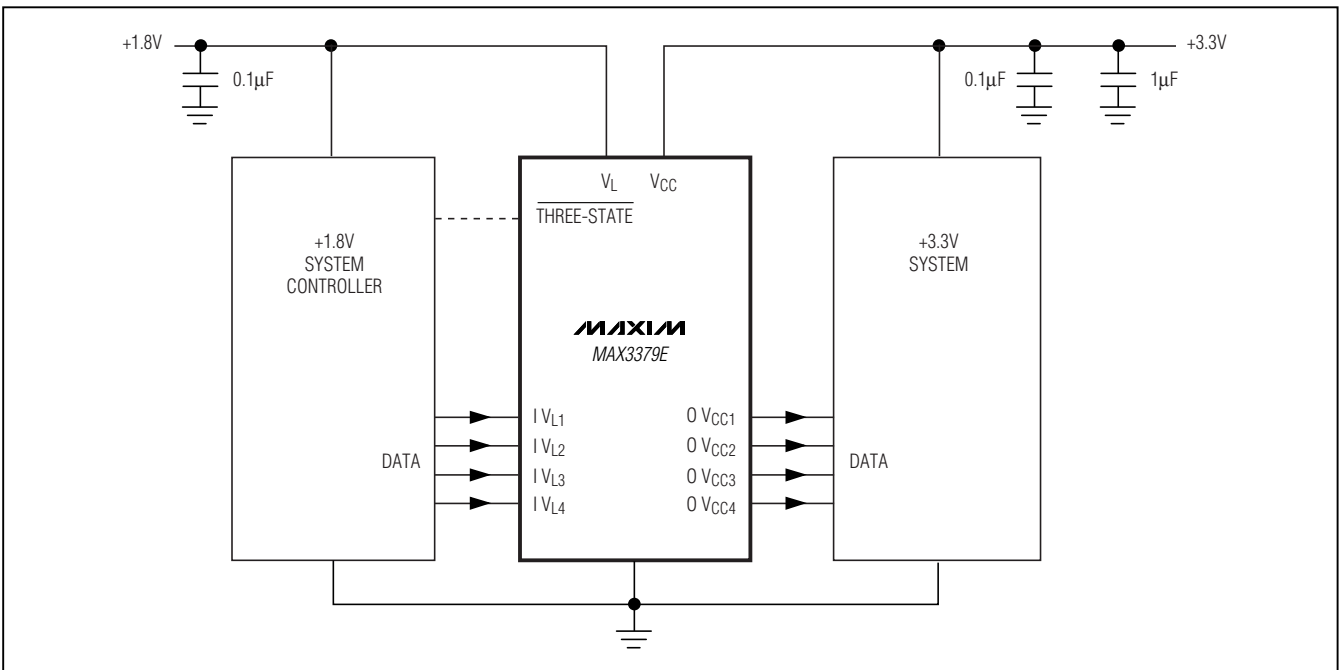
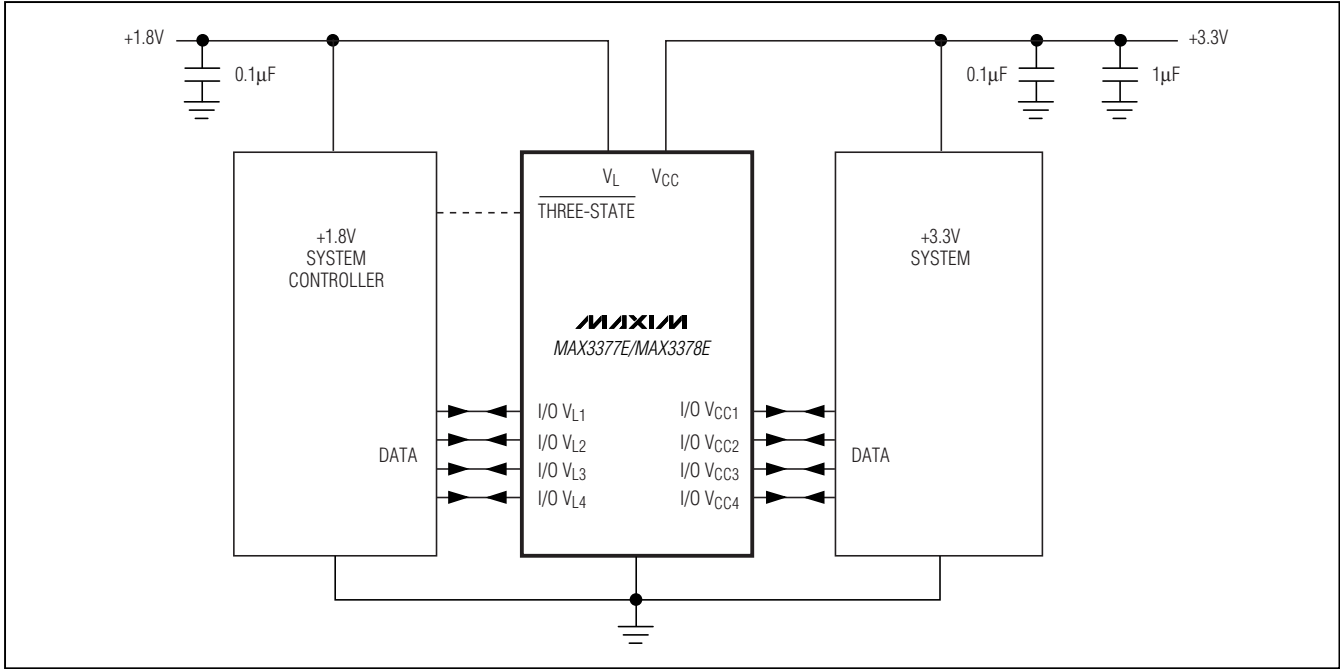

MAX3372E-MAX3379E/MAX3390E-MAX3393E

±15kV ESD-Protected, 1µA, 16Mbps, Dual/Quad Low-Voltage Level Translators in UCSP

Applications Circuits (continued)

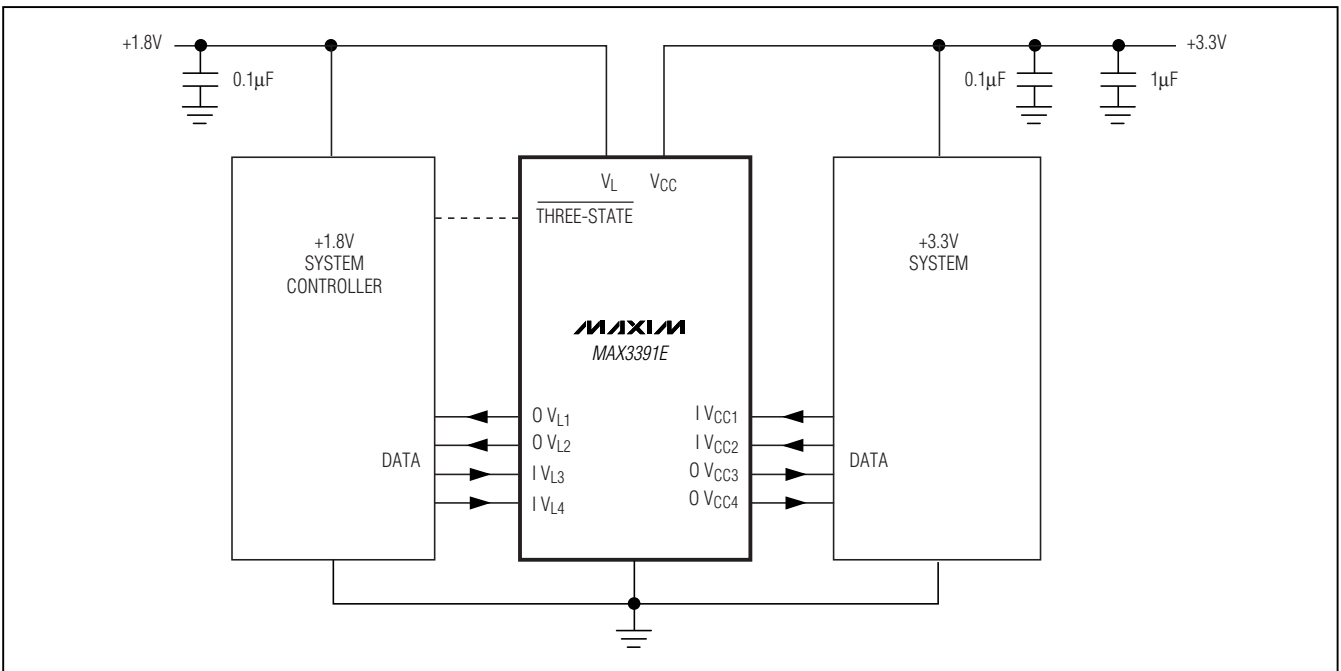
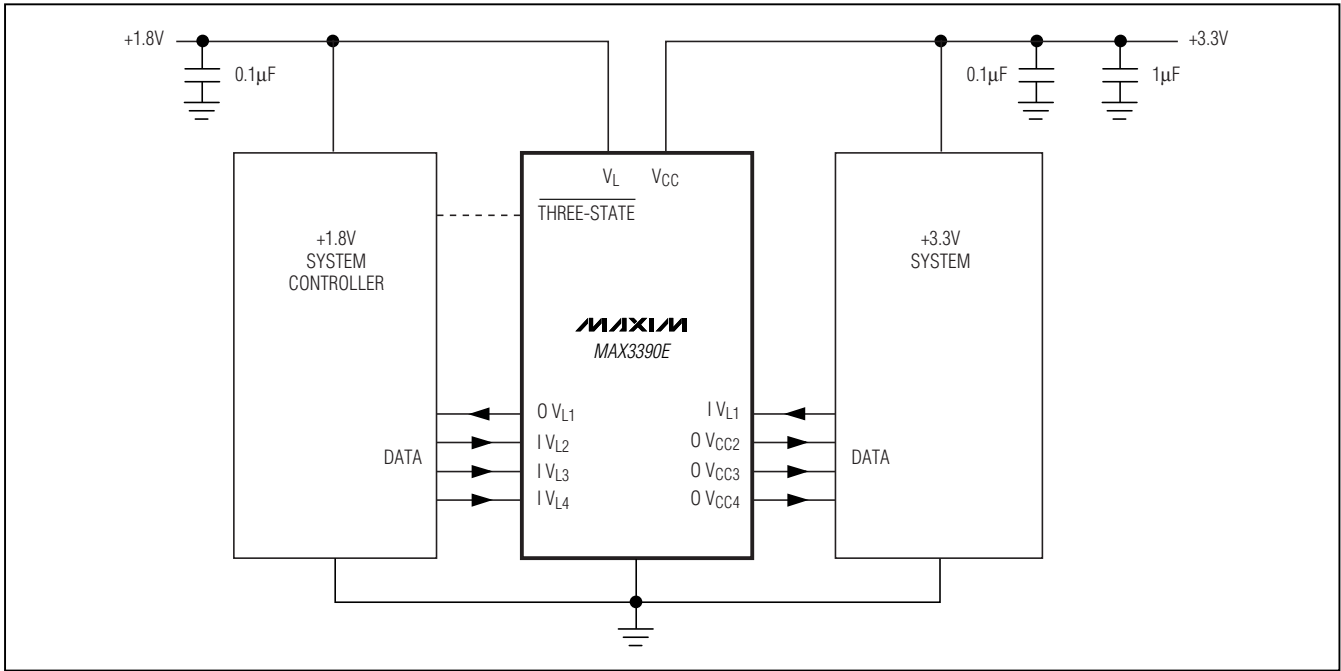

±15kV ESD-Protected, 1µA, 16Mbps, Dual/Quad Low-Voltage Level Translators in UCSP

Applications Circuits (continued)

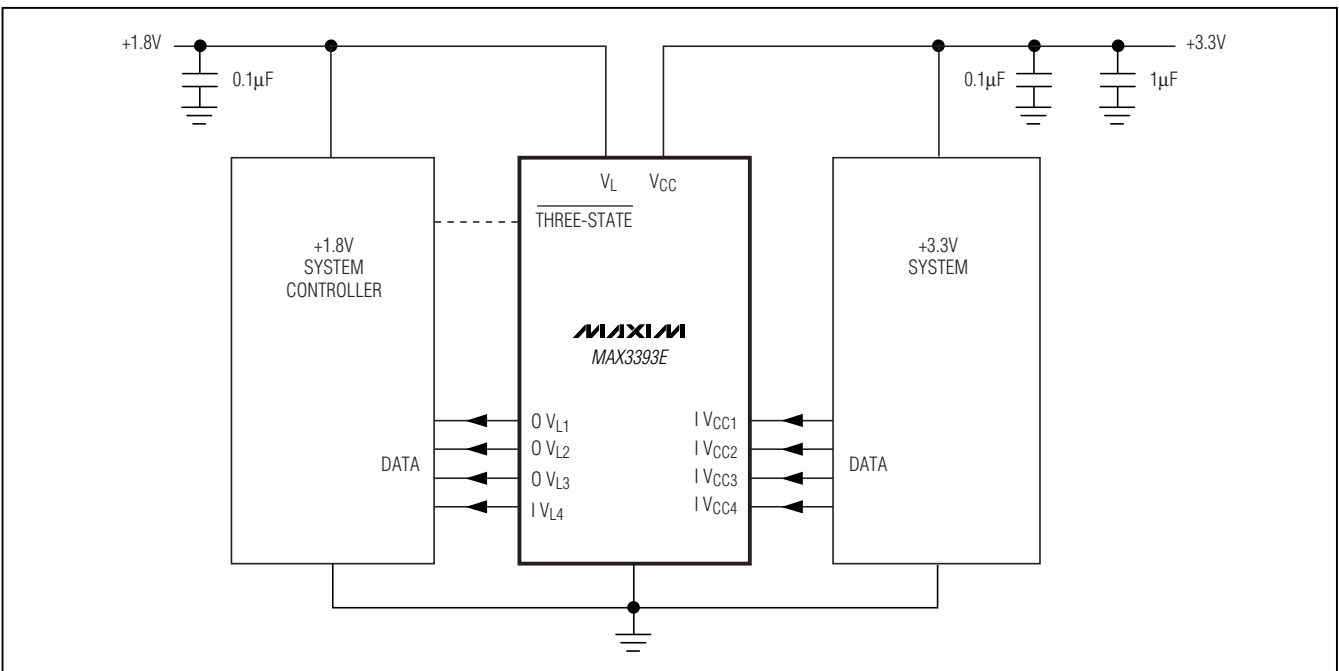
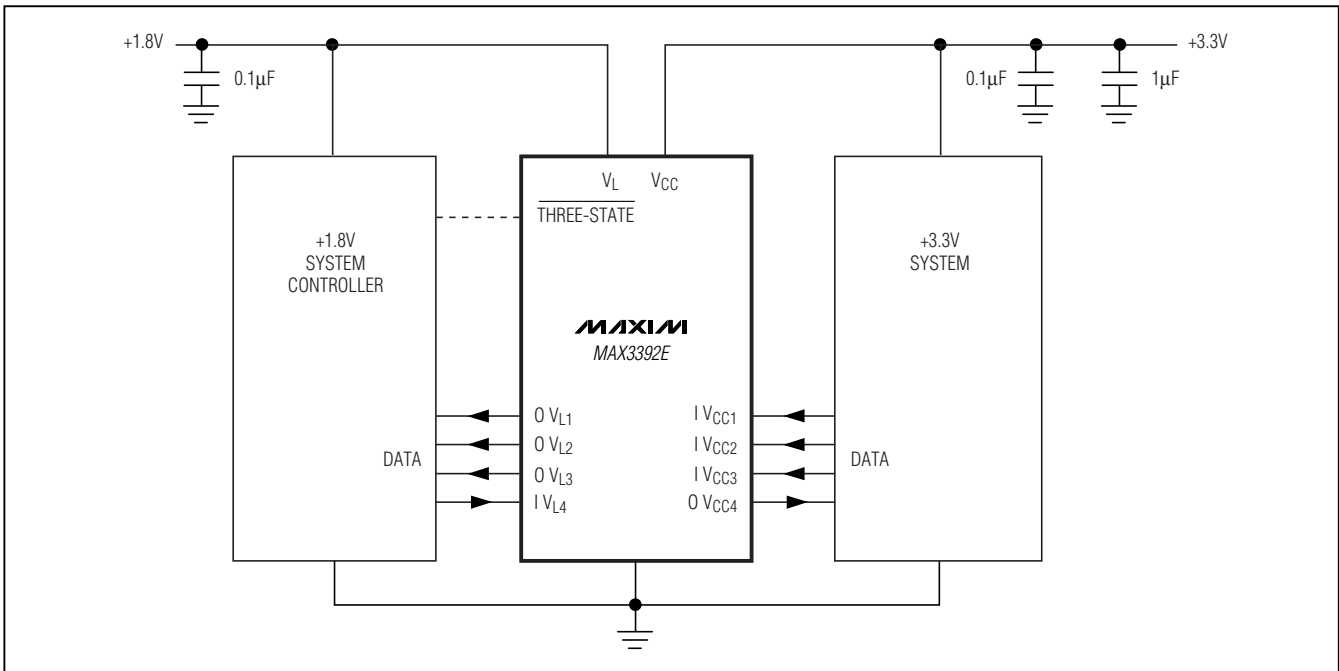

MAX3372E-MAX3379E/MAX3390E-MAX3393E

±15kV ESD-Protected, 1µA, 16Mbps, Dual/Quad Low-Voltage Level Translators in UCSP

Selector Guide

PART	LEVEL TRANSLATION	Tx/Rx†	DATA RATE	TOP MARK	
MAX3372EEKA-T	✓ Bi	2/2	230kbps	AAKO	
MAX3372EEBL-T	✓ Bi	2/2		AAR	
MAX3373EEKA-T	✓ Bi	2/2	8Mbps*	AAKS	
MAX3373EEBL-T	✓ Bi	2/2		AAZ	
MAX3374EEKA-T	Uni	2/0		AALH	
MAX3374EEBL-T	Uni	2/0		ABA	
MAX3375EEKA-T	Uni	1/1		AALI	
MAX3375EEBL-T	Uni	1/1		ABB	
MAX3376EEKA-T	Uni	0/2		AALG	
MAX3376EEBL-T	Uni	0/2		AAV	
MAX3377EEUD	✓ Bi	4/4		230kbps	—
MAX3377EEBC-T	✓ Bi	4/4			AAX
MAX3378EEUD	✓ Bi	4/4	8Mbps*	—	
MAX3378EEBC-T	✓ Bi	4/4		AAZ	
MAX3379EEUD	Uni	4/0		—	
MAX3379EEBC-T	Uni	4/0		AAZ	
MAX3390EEUD	Uni	3/1		—	
MAX3390EEBC-T	Uni	3/1		ABA	
MAX3391EEUD	Uni	2/2		—	
MAX3391EEBC-T	Uni	2/2		ABB	
MAX3392EEUD	Uni	1/3		—	
MAX3392EEBC-T	Uni	1/3		ABC	
MAX3393EEUD	Uni	0/4	—		
MAX3393EEBC-T	Uni	0/4	ABD		

†Tx = VL → VCC, Rx = VCC → VL

*Higher data rates are possible (see Timing Characteristics).

Ordering Information (continued)

PART	TEMP RANGE	PIN-PACKAGE	PKG CODE
MAX3372EEBL-T	-40°C to +85°C	3 × 3 UCSP	B9-2
MAX3373EEKA-T	-40°C to +85°C	8 SOT23-8	K8S-3
MAX3373EEBL-T	-40°C to +85°C	3 × 3 UCSP	B9-2
MAX3374EEKA-T	-40°C to +85°C	8 SOT23-8	K8S-3
MAX3374EEBL-T	-40°C to +85°C	3 × 3 UCSP	B9-2
MAX3375EEKA-T	-40°C to +85°C	8 SOT23-8	K8S-3
MAX3375EEBL-T	-40°C to +85°C	3 × 3 UCSP	B9-2
MAX3376EEKA-T	-40°C to +85°C	8 SOT23-8	K8S-3
MAX3376EEBL-T	-40°C to +85°C	3 × 3 UCSP	B9-2
MAX3377EEUD	-40°C to +85°C	14 TSSOP	U14-1
MAX3377EEBC-T	-40°C to +85°C	3 × 4 UCSP	B12-1
MAX3378EEUD	-40°C to +85°C	14 TSSOP	U14-1
MAX3378EEBC-T	-40°C to +85°C	3 × 4 UCSP	B12-1
MAX3379EEUD*	-40°C to +85°C	14 TSSOP	U14-1
MAX3379EEBC-T*	-40°C to +85°C	3 × 4 UCSP	B12-1
MAX3390EEUD*	-40°C to +85°C	14 TSSOP	U14-1
MAX3390EEBC-T*	-40°C to +85°C	3 × 4 UCSP	B12-1
MAX3391EEUD*	-40°C to +85°C	14 TSSOP	U14-1
MAX3391EEBC-T*	-40°C to +85°C	3 × 4 UCSP	B12-1
MAX3392EEUD*	-40°C to +85°C	14 TSSOP	U14-1
MAX3392EEBC-T*	-40°C to +85°C	3 × 4 UCSP	B12-1
MAX3393EEUD*	-40°C to +85°C	14 TSSOP	U14-1
MAX3393EEBC-T*	-40°C to +85°C	3 × 4 UCSP	B12-1

*Future product—contact factory for availability.

±15kV ESD-Protected, 1µA, 16Mbps, Dual/Quad Low-Voltage Level Translators in UCSP

Pin Configurations (continued)

MAX3372E-MAX3379E/MAX3390E-MAX3393E

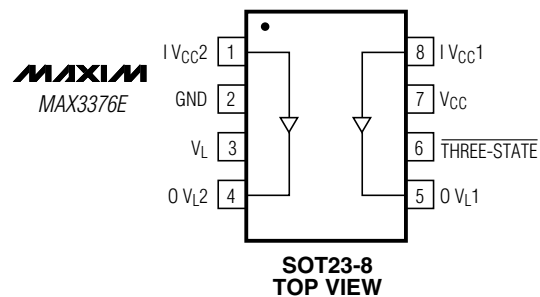
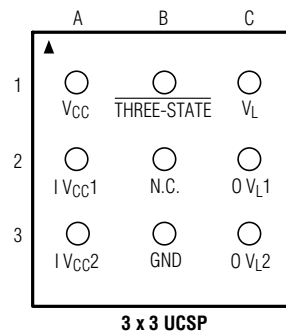
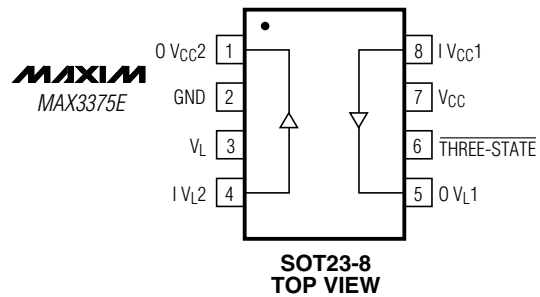
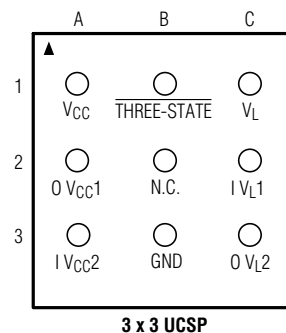
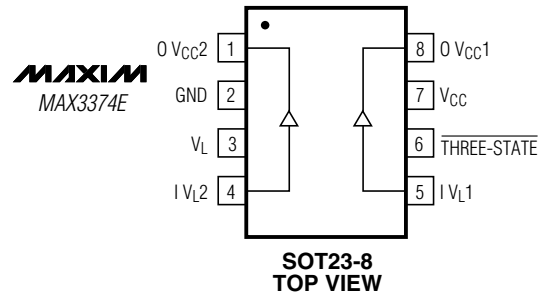
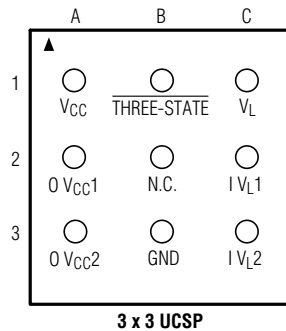
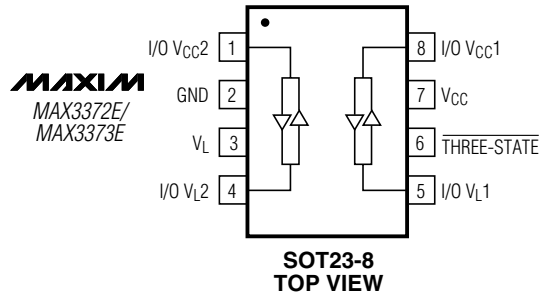
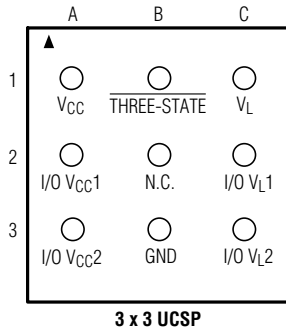

±15kV ESD-Protected, 1µA, 16Mbps, Dual/Quad Low-Voltage Level Translators in UCSP

Pin Configurations (continued)

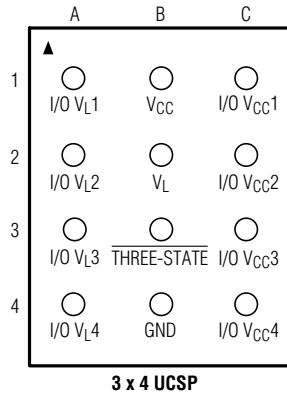

MAXIM
MAX3377E/
MAX3378E

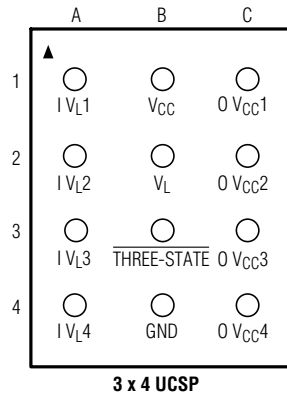
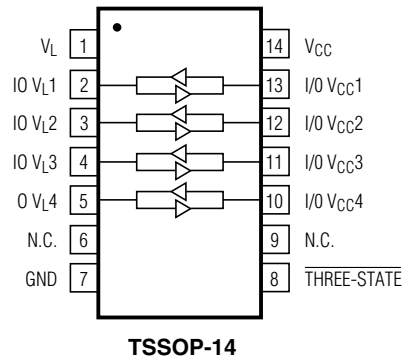

MAXIM
MAX3379E

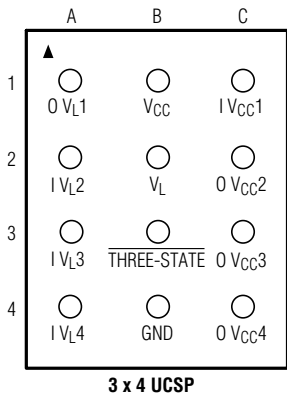
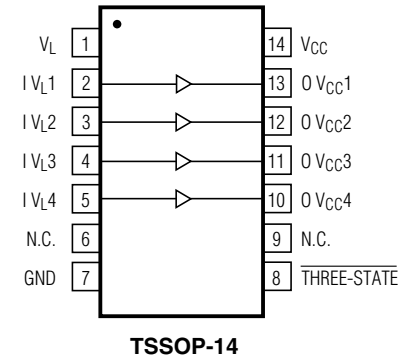

MAXIM
MAX3390E

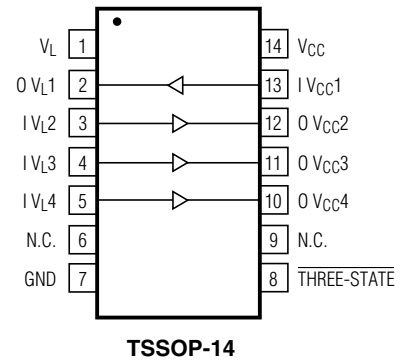

±15kV ESD-Protected, 1µA, 16Mbps, Dual/Quad Low-Voltage Level Translators in UCSP

Pin Configurations (continued)

MAX3372E-MAX3379E/MAX3390E-MAX3393E

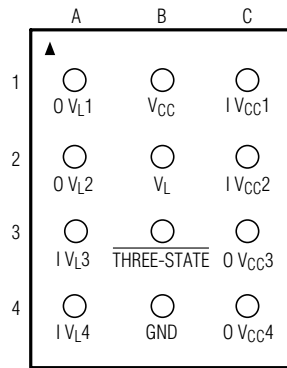

3 x 4 UCSP

MAXIM
MAX3391E

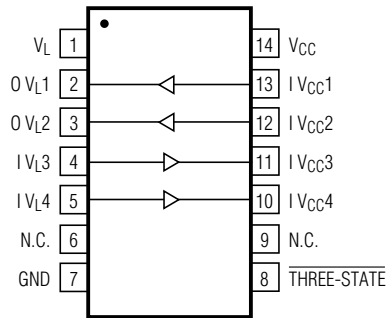

TSSOP-14

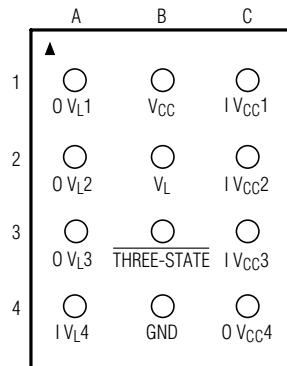

3 x 4 UCSP

MAXIM
MAX3392E

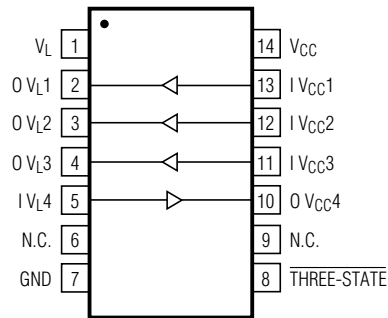

TSSOP-14

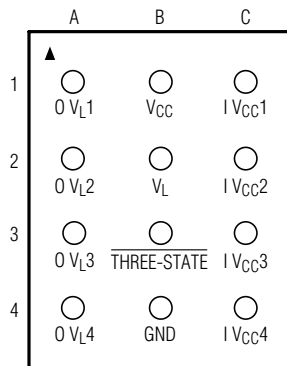

3 x 4 UCSP

MAXIM
MAX3393E

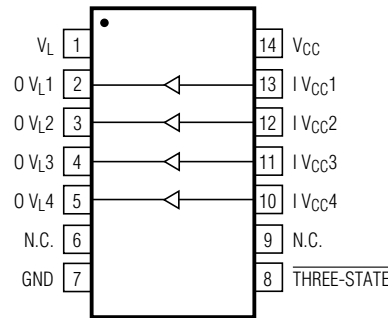

TSSOP-14

±15kV ESD-Protected, 1µA, 16Mbps, Dual/Quad Low-Voltage Level Translators in UCSP

Chip Information

TRANSISTOR COUNT: MAX3372E-MAX3376E: 189
 MAX3377E-MAX3379E,
 MAX3390E-MAX3393E: 295
 PROCESS: BiCMOS

Package Information

(The package drawing(s) in this data sheet may not reflect the most current specifications. For the latest package outline information go to www.maxim-ic.com/packages.)

SYMBOL	MIN	MAX
A	0.90	1.45
A1	0.00	0.15
A2	0.90	1.30
b	0.28	0.45
C	0.09	0.20
D	2.80	3.00
E	2.60	3.00
E1	1.50	1.75
L	0.30	0.60
L2	0.25 BSC.	
e	0.65 BSC.	
e1	1.95 REF.	
θ	0°	8°

NOTE:

- ALL DIMENSIONS ARE IN MILLIMETERS.
- △ FOOT LENGTH MEASURED FROM LEAD TIP TO UPPER RADIUS OF HEEL OF THE LEAD PARALLEL TO SEATING PLANE C.
- PACKAGE OUTLINE EXCLUSIVE OF MOLD FLASH & METAL BURR.
- PACKAGE OUTLINE INCLUSIVE OF SOLDER PLATING.
- COPLANARITY 4 MILS. MAX.
- PIN 1 I.D. DOT IS 0.3 MM γ MIN. LOCATED ABOVE PIN 1.
- SOLDER THICKNESS MEASURED AT FLAT SECTION OF LEAD BETWEEN 0.08mm AND 0.15mm FROM LEAD TIP.
- MEETS JEDEC MO178.

DALLAS SEMICONDUCTOR **MAXIM**
 PROPRIETARY INFORMATION
 TITLE: PACKAGE OUTLINE, SOT-23, 8L BODY
 APPROVAL: DOCUMENT CONTROL NO. 21-0078 REV. D 1/1

SOT23, 8L EP5

±15kV ESD-Protected, 1µA, 16Mbps, Dual/Quad Low-Voltage Level Translators in UCSP

Package Information (continued)

(The package drawing(s) in this data sheet may not reflect the most current specifications. For the latest package outline information go to www.maxim-ic.com/packages.)

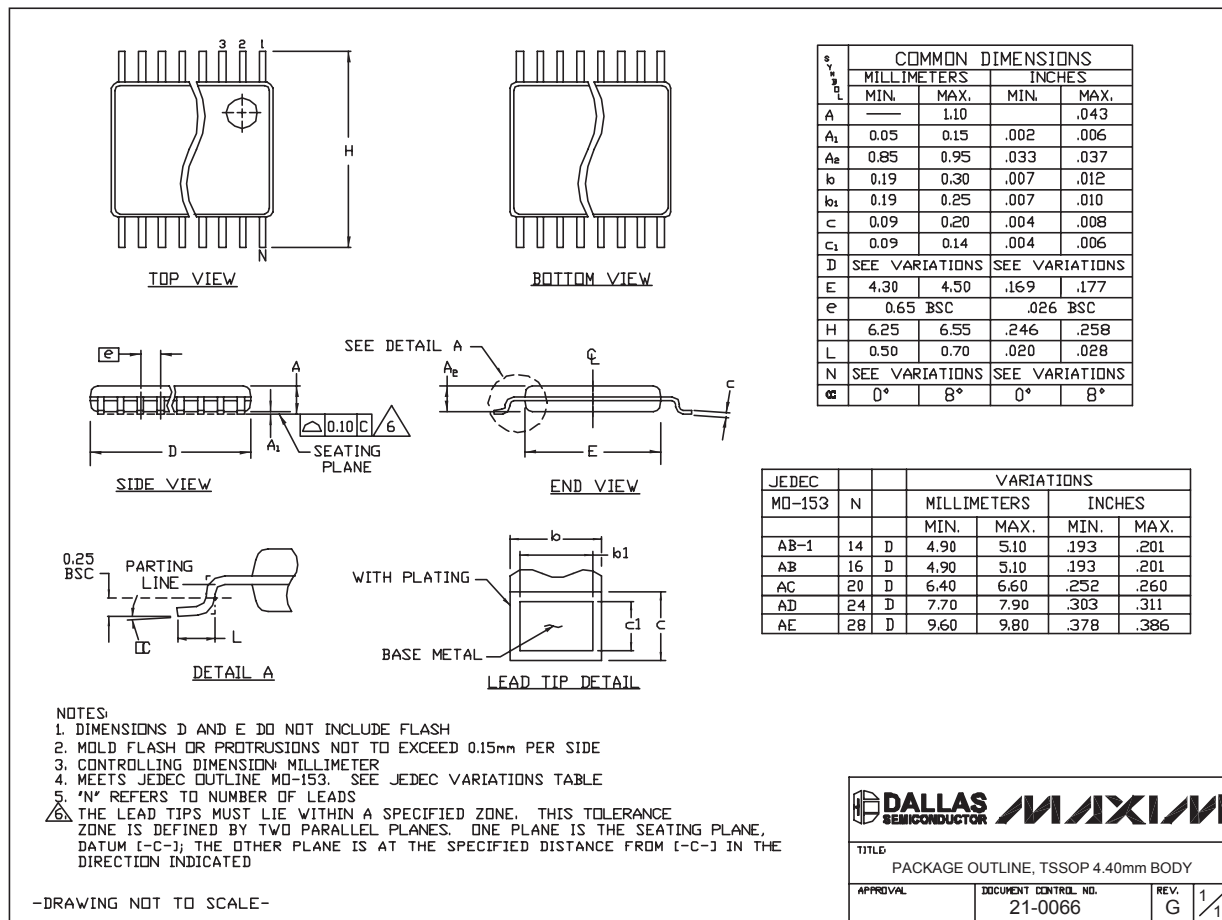

TSSOP4_40mm.EPS

MAX33372E-MAX33379E/MAX33390E-MAX33393E

Maxim cannot assume responsibility for use of any circuitry other than circuitry entirely embodied in a Maxim product. No circuit patent licenses are implied. Maxim reserves the right to change the circuitry and specifications without notice at any time.

Maxim Integrated Products, 120 San Gabriel Drive, Sunnyvale, CA 94086 408-737-7600 _____ 25