

Simple Circuit Monitors Health of –48V Telecom Lead-Acid Battery Backup Systems

Jon Munson

Telecommunications infrastructure has always been powered by voltages that are negative with respect to ground to minimize corrosion in buried cable. Telcos typically use –48V power, with backup power supplied by large battery arrays to carry the system through utility outages. These power backup systems traditionally comprise four 12V lead-acid batteries in series, though newer lithium cell technology promises to make inroads as systems are updated.

Every battery backup system must be continually monitored for the charge state and health of the batteries. In fact, although stacking batteries is easy, it can be difficult to build a monitoring system that can measure and digitize both the condition of individual cells,

and monitor the high voltage potential of the combined cells. Enter the LTC6803 multicell battery stack monitor.

The LTC6803 is designed to measure and digitize individual cell potentials in large lithium cell stacks with total potentials

beyond 60v (surviving surges to 75v). Although the LTC6803 is ostensibly designed to monitor lithium-based battery systems, it can just as well be used to support traditional –48v lead-acid battery stacks. Regardless of cell chemistry, all the measuring potentials are below ground

Figure 1. Isolated lead-acid telecom battery-stack monitor

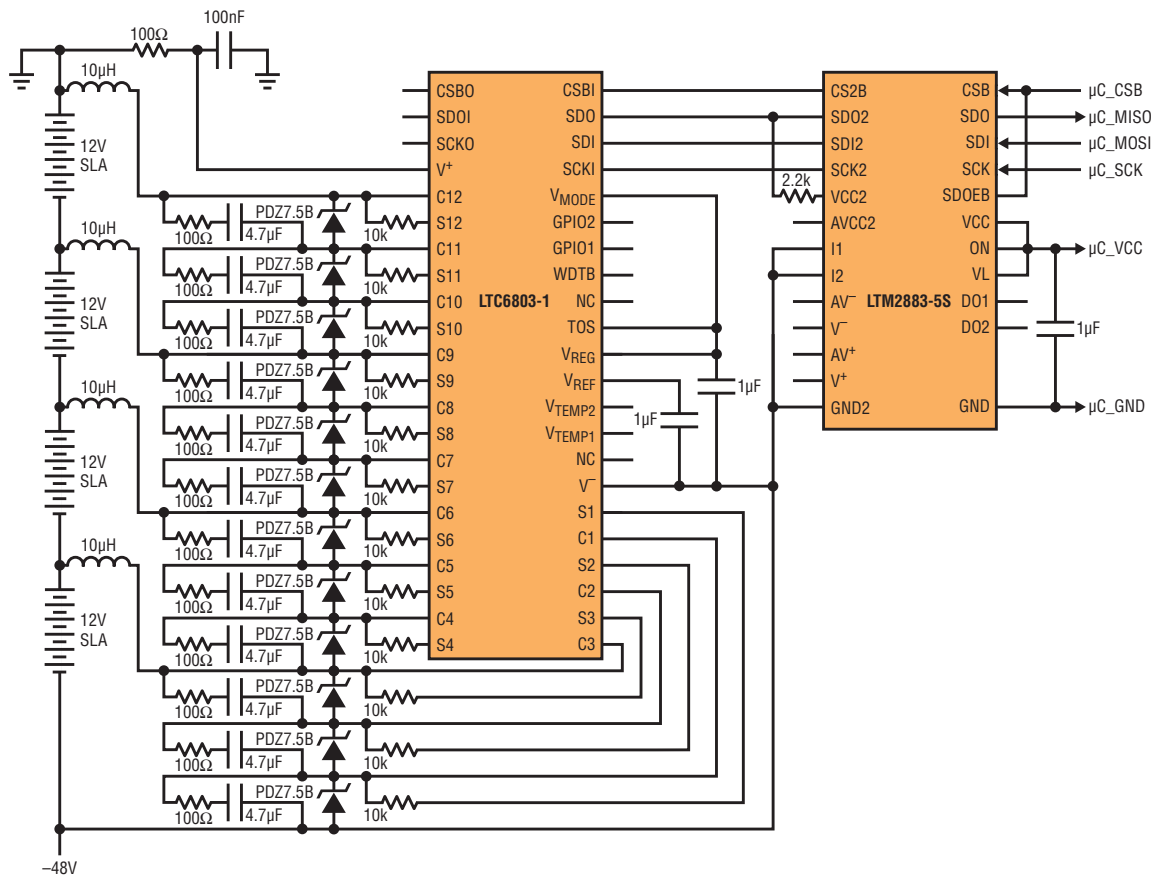

Although the LTC6803 is ostensibly designed to monitor lithium-based battery systems, it can also be used to support traditional –48V lead-acid battery stacks.

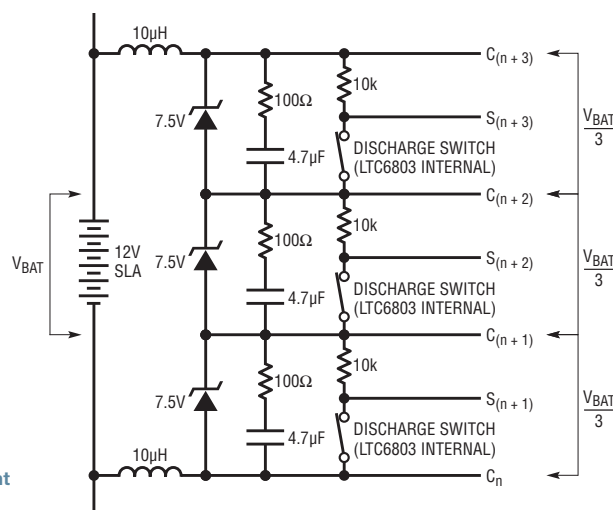

Figure 2. Voltage-divider structure for each 12V battery measurement

or possibly floating during maintenance procedures. Ideally, these batteries should be measured by circuitry that is independent of the relative grounding between the batteries and the central-office equipment, thus Galvanic isolation is desirable.

A SIMPLE SOLUTION FOR LEAD-ACID STACKS

Since the ADC range for an individual LTC6803 input channel maxes out at 5.37V, divider networks are used to spread each 12V battery potential across three channels. Figure 1 shows how. Each battery potential is acquired by summing triplets of input channel readings (C_N inputs). Here the cell-balancing controls (S_N output discharge switches) are re-purposed to continually activate voltage dividers using external 10k resistors by setting all DCC configuration bits to 1. In this way, each channel is converting a 4V nominal potential.

The 4.7µF bypass capacitors accurately hold the intermediate voltages as small ADC sampling currents flow, while 100Ω series resistors and 10µH inductors provide hot-insert surge limiting. For best accuracy, the STCVDC conversion command (0x60) should be used so that the always-enabled discharge switches remain on throughout the conversion process.

When communication has stopped and the part times-out, or it is directly commanded to standby mode, the balancing discharge switches are turned off and the dividers are effectively disconnected so that no appreciable battery drain occurs. A simplified equivalent circuit of a particular divider section is shown in Figure 2.

An LTM2883 SPI data isolator is used so that the circuit accommodates any grounding differential with respect

to the associated microprocessor circuitry. The LTM2883 also provides isolated DC power rails that can furnish several hundred mW if needed.

CONCLUSION

The LTC6803 provides a flexible solution for telecom battery stack measurement, including stacks using 12V lead-acid batteries. The 12V units are measured by summing the readings of three input channels that have been hardware configured to split the 12V into sub-measurements, thus achieving an effective full-scale range of 16.1V for each battery. Isolation of the data acquisition function from the processor support is important for elimination of grounding errors and safety hazards and is readily provided by the LTM2883 SPI isolator module. ■