



A GREATER MEASURE OF CONFIDENCE

## Precise Measurement FAQs

Here are some Frequently Asked Questions and Answers associated with low level measurements. If you don't find answers to your questions here, you can send a specific question to Keithley's Applications Engineering Department. You'll receive a personal answer to your question. Send your e-mail to [ustechsupport@keithley.com](mailto:ustechsupport@keithley.com).

### **Question: How do I apply an instrument's accuracy specification?**

**Answer:** An accuracy specification represents the degree of uncertainty inherent in a measurement made by a specific instrument, under a specific set of environmental or other qualifying conditions. Generally, the accuracy specification is understood to be a level of performance that can be achieved by any sample of the product line.

A typical expression of accuracy is  $\pm(\text{gain error} + \text{offset error})$ . However, manufacturers can use different formats to express accuracy, so it can be difficult to compare instruments. Gain and offset errors are sometimes bundled into a specification that expresses accuracy purely in terms of A/D counts or parts per million.

The graph below shows the relationship of the gain and offset error components over a measurement range. When the instrument is operated in the lower part of a selected range, the offset error is the dominant term. When operated near the full-scale value for a selected range, the gain error becomes significant.

## Uncertainty vs. Reading % of full scale

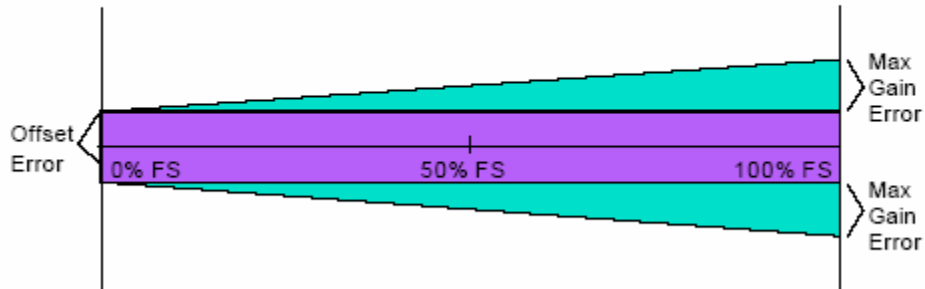

Instrument specifications can be stated in a variety of ways: parts per million (ppm), percent, or counts. (ppm is used instead of percent when the magnitude of the numbers is small; 10,000 ppm = 1%)

Below are some calculation examples in ppm, percent, and counts formats:

### To calculate uncertainty when specifications are given in ppm:

$$\text{Uncertainty} = [(\text{ppm of reading} * \text{applied value}) + (\text{ppm of range} * \text{range used})] / 1,000,000$$

#### Example

<i>DC</i>	<u>Range</u>	<u>Accuracy ± (ppm of reading + ppm of range)</u>
<i>Voltage</i>	100.00mV	30 + 35
<i>Meter</i>	1.00V	30 + 7

$$\text{Uncertainty of 0.5V on the 1V range} = [(30 * 0.5V) + (7 * 1V)] / 1,000,000 = \pm 22\mu V$$

### To calculate uncertainty when specifications are given in percentage :

$$\text{Uncertainty} = [(\% \text{ of reading} * \text{applied value}) + (\% \text{ of range} * \text{range used})]$$

#### Example

<i>DC</i>	<u>Range</u>	<u>Accuracy ± (% of reading + amps)</u>
<i>Current</i>	1.00μA	0.035% + 600pA
<i>Source</i>	10.00μA	0.033% + 2nA

$$\text{Uncertainty of 3.5}\mu A \text{ on } 10\mu A \text{ range} = [(.00033 * 3.5\mu A) + 2nA] = \pm 3.16nA = \pm 0.09\%$$

### To calculate uncertainty when specifications are given in counts:

Unless specified otherwise, 1 count = 1 unit of the resolution on the range used

$$\text{Uncertainty} = (\text{counts of reading} + \text{counts of range})$$

Example

<u>Resistance</u>	<u>Resolution</u>	<u>Range</u>	<u>Accuracy ± (% of reading + counts)</u>
<i>Meter</i>	100mOhms	2kOhms	0.04% + 2
<i>(4.5 digits)</i>	1 Ohm	20kOhms	0.05% + 2

Uncertainty of 1.75kOhm on 2kOhm range =  
[(0.0004 \* 1.75kOhm) + (2 \* 100mOhms)] = ± 900mOhms

The accuracy specification provided in a data sheet usually reflects only measurement uncertainty attributable to the hardware. The hardware will always be affected by variations in the manufacturing of electronics components and subassemblies.

Amplifiers, resistors, and A/D converters are the main contributors to these variations. The specifications also include a time span from the last calibration over which the specification applies, such as 24-hour, 90-day, etc.

A possible source of an out-of-spec reading is that the hardware is defective, but has not failed outright. The adoption of calibration cycles for test and measurement instruments will help eliminate this possibility; experienced calibration technicians can recognize the need for abnormal adjustment to bring an instrument back into calibration.

However, external sources of error can also enter into measurements, including such sources as power line (50/60 Hz) noise, lead resistance, magnetic interference, ground loops, thermoelectric EMFs, and RF. These sources of errors are not included in accuracy specifications, so test procedures need to incorporate safeguards against them.

**Question: What is temperature coefficient and how is it applied?**

**Answer:** Temperature coefficient is the specification that is added to the general accuracy specification when the measuring instrument is at an ambient temperature that is outside the normal operating temperature. It is calculated by the following manner:

The specification is normally defined as percent per degree. This means for each degree outside of the normal operating temperature this percentage is added to the normal accuracy specification. In general, the temperature coefficient is much less than the normal accuracy. The normal operating temperature is 18° to 28°C.

Example:

Temperature Coefficient = 0.0001%/C.

Accuracy = 20ppm of reading + 20ppm of range.

The accuracy in measuring a 0.5V signal on the 1V range for the 90-day specification is 30ppm or 0.03% or 30 microvolts. (Refer to accuracy calculation FAQ above.) Now consider that the unit is at 33°C ambient temperature. Since this is 5°C outside the normal operating temperature, the temperature coefficient is going to apply to the normal specification.

The temperature coefficient is stated as 0.0001% for each °C; 0.0001% = 0.000001 = 1ppm, and 5 \* 1ppm = 5ppm (or 0.0005%). Five parts per million added to the normal specification of 30ppm is 35 ppm or 0.00035% total uncertainty. For the 0.5V signal being measured, this results in 35 microvolts of uncertainty. A reported reading in the range of 0.499965 to 0.500035 will be within tolerance.

**Question: How do I measure the offset current of my picoammeter or electrometer?**

**Answer:** The offset current of a picoammeter or electrometer is the current measured with no circuit connected to the input. To measure the offset current, turn the power on and allow the instrument to warm up for the time specified in the manual. Place a shield cap over the input connector. Connect the LO input terminal to ground (if your instrument has these terminals). Set the meter to the most sensitive current range and disable the zero check switch. After a few seconds, the meter readings should settle to within a few digits. This settled reading is the input offset current. This reading should be compared to the specification in the instrument's manual. If the offset current is too high, the instrument probably needs recalibration.

**Question: How does an electrometer differ from a Digital MultiMeter (DMM)?**

**Answer:** Similar to a DMM, electrometers offer multiple measurement functions such as volts, current, and ohms. However, the electrometer has special input characteristics that offer special advantages for measurement of low values of current or high values of resistance.

For example, the Volts function has much higher input impedance than a DMM, which minimizes the electrometer's circuit loading. Its resistance function offers extended ranges into the giga- or tera-ohm range. DMMs typically determine resistance by sourcing a current and measuring the resulting voltage. An important difference from the DMM is the ability of the electrometer to source a known voltage and measure the resulting current to determine resistance. This is especially important for materials whose resistance will vary as a function of the applied voltage such as is seen with insulating materials. The current function of an electrometer has much better sensitivity than a DMM. Electrometers also offer a charge function.

**Question: What are the differences between an electrometer, picoammeter and current amplifier?**

**Answer:** Picoammeters, such as the Keithley Models 6485 or 6487, measure current only. For these measurements, picoammeters are similar to an electrometer design. However, electrometers have multiple functions (they also measure resistance and charge), and offer more sensitive ranges for current measurements. Greater sensitivity provides better resolution and improved accuracy for extremely low current measurements. Electrometers are a better solution for accurate measurements in the picoamperes range.

As usual, speed is a tradeoff for this accuracy advantage. An electrometer's preamp settling time (defined as settling to within 10% of final value) on its picoampere ranges is about 2.5 seconds. The preamp settling time on the nanoampere ranges is similar to the picoammeter's nanoampere range, which is in on the order of milliseconds.

If fast acquisition is a critical application requirement, a current amplifier may be the preferred solution. Unlike the picoammeters and electrometers, the Model 428 Current Amplifier offers selectable filters to accommodate for noise / speed tolerances. The 10 – 90% rise time can be configured as fast as 250 $\mu$ S on the 10E11 gain range with a 2pA rms noise level, or as slow as 300mS with 1.2fA rms noise level. Also different from the picoammeter and electrometer design, the current amplifier does not offer an internal A/D converter. The Model 428 has a 0-10V analog output. This output can be used with data acquisition boards, oscilloscopes, or waveform digitizers for a low current measurement system or real time display.

**Question: Why does my picoammeter (or electrometer in the current mode) give a non-zero reading when I short the input?**

**Answer:** When measuring current, the input circuit is an op amp in a current-to-voltage converter configuration, also known as a transimpedance amplifier. As such, the feedback is 100% when the input is connected to a true current source.

However, if the input is shorted the feedback is ZERO, and all the input stage noise and voltage offset shows up on the display. A voltmeter should be shorted to check for offset, drift, etc., but an ammeter should be open circuited.

To determine the zero offset of your picoammeter or electrometer in current mode, use the Zero Check feature.

**Question: What is offset compensation?**

**Answer:** Offset compensation is a measuring technique that reduces or eliminates thermoelectric EMFs in low level resistance measurements. Every connection made with dissimilar metals creates an unwanted thermocouple in the measurement circuit (Figure 1). Each of these unwanted thermocouples generates an error voltage that varies with temperature gradients in the system. These can be on the order of many microvolts that

can cause significant errors in thermistor, RTD, strain gauge, and low level ohms measurements.

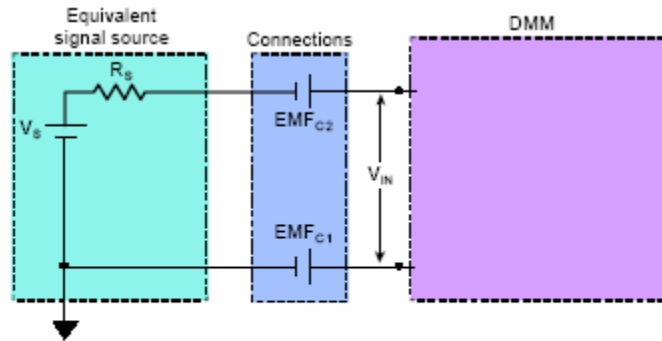

Example:

Every connection made with dissimilar metal creates an unwanted thermocouple.

**Figure 1.** Thermoelectric EMFs in connections.

One method of minimizing thermoelectric EMF errors is by using the offset compensated ohms measurement technique (Figure 2). Using this technique, test current is applied to the circuit and the resulting voltage measurement will include the desired DUT measurement as well as the effect of thermoelectric EMFs.

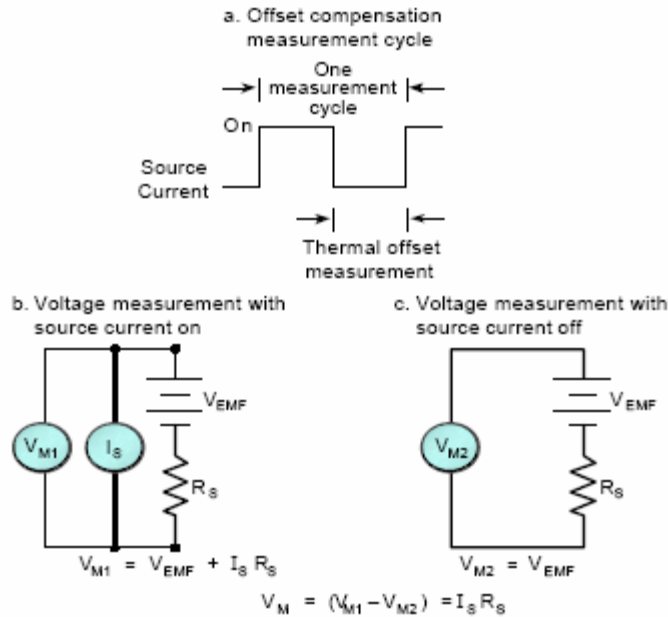

**Figure 2.** Thermoelectric EMF Offset Compensated Ohms Method.

During the second half of the cycle, however, test current is turned off. The resulting voltage measurement is therefore attributable only to the thermoelectric EMFs present in the circuit. The desired measurement is the difference between the two values. The microprocessor in the DMM compensates for the offset voltage.

Keithley products that provide this offset compensation feature include the Models 580, 2010, 2001, 2002, 2700, 2750, and the Series 2400 SourceMeter line.

**Question: What is pumpout current and when might it pose a problem for my measurements?**

**Answer:** Pumpout current is a small discharge of current at the meter input. This current discharge is a result of the switching the instrument performs between measurements of the input signal and the background measurements performed by the analog to digital (A/D) converters, which include measurement of reference and zero points.

Pumpout current can sometimes be a problem for low level signals. Measurements made by DMMs and nanovoltmeters, in particular, can be affected by pumpout current. A symptom of a pumpout current problem is when there appear to be noise injections in



the measurement results. It may be easier to consider pumpout current as bursts of charge. These small charges develop an error voltage across the source of voltage being measured.

To reduce the effect of pumpout current, you may do one of two things: (1) Choose a meter with a low pumpout current. The Keithley Model 2182 Nanovoltmeter has the lowest pumpout current of any nanovoltmeter in the industry. (2) Disable autozero, which will remove A/D switching from the input signal to the reference and zero points. However, disabling autozero for extended periods of time will cause measurements to drift. You should periodically re-enable autozero (every 10 minutes or so) to update the background measurements. Some instruments have an “AutoZero once” command, which forces an immediate update of the zero and reference readings.

###