

## PRODUCT OVERVIEW

For applications requiring improved electrical and thermal performance, consider Murata's new HPH series "Half Brick" DC/DC power converters. These compact modules measure 2.4" X 2.3" X 0.4" (61 X 58 X 10.2mm) and offer the industry-standard Half Brick footprint.

The module will provide a 12Vdc output at 30Amps and accept a wide range input voltage of 36-75Vdc. The HPH topology offers high efficiency

up to 93%, tight line and load regulation, low ripple/noise, and a fast dynamic load response. A single-board, highly optimized thermal design contributes to the superior thermal performance.

These DC/DC's provide output trim, sense pins, and primary side on/off control. Standard features also include input under-voltage shutdown, output over-voltage protection, output short-circuit/current limiting protection, and thermal shutdown.

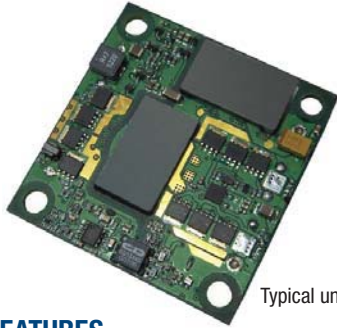

Typical unit

## FEATURES

- 12V<sub>out</sub> @ 30A (360W)
- Industry Standard "Half Brick" package
- High Efficiency: up to 93%
- Outstanding thermal performance
- Optional Baseplate for conduction cooled applications
- No output reverse conduction
- Input to Output Isolation, 2250Vdc (Basic)
- Input under-voltage lockout
- On/Off Control (Positive or Negative Logic)
- Output over-voltage protection
- Thermal shutdown
- Output short circuit protection (hiccup technique)

Contents	Page
Description, Photograph, Connection Diagram	1
Ordering Guide, Model Numbering	2
Mechanical Specs, Input/Output Pinout	3
Detailed Electrical Specifications	4
Application Notes	7
Soldering Guidelines	10
Performance Data	11

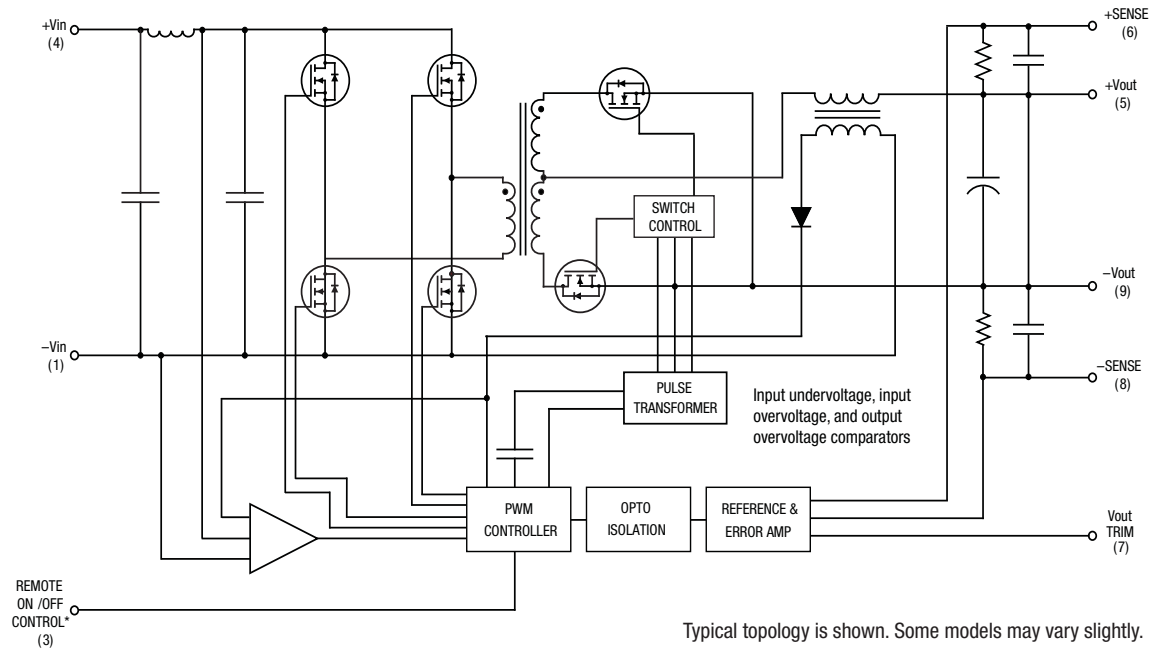

Figure 1. Simplified Schematic

Typical topology is shown. Some models may vary slightly.  
\* Can be ordered with positive (standard) or negative (optional) polarity.



For full details go to  
[www.murata-ps.com/rohs](http://www.murata-ps.com/rohs)



PERFORMANCE SPECIFICATIONS AND ORDERING GUIDE															
Root Model ①	Output						Input				Efficiency		Package (Case/ Pinout)		
	V <sub>OUT</sub> (Volts) ②	I <sub>OUT</sub> (Amps, Max.) ②	Power (Watts)	R/N (mV pk-pk)		Regulation (Max.)		V <sub>IN</sub> Nom. (Volts)	Range (Volts)	I <sub>IN</sub> , no load (mA)	I <sub>IN</sub> , full load (Amps)	Min.	Typ.	C61	P17
				Typ.	Max.	Line	Load								
HPH-12/30-D48	12	30	360	100	200	±0.05%	±0.1%	48	36-75	150	8.1	92%	93%	C61	P17

- ① Please refer to the full model number structure for additional ordering part numbers and options.
- ② Please refer to maximum input/output voltage graph.
- ③ All specifications are at nominal line voltage and full load, +25°C. unless otherwise noted. See detailed specifications.
- ④ Full power continuous output requires baseplate installation. Please refer to the derating curves.

### PART NUMBER STRUCTURE

**HPH - 12 / 30 - D48 N B H Lx - C**

- HPH** - High-Power Half Brick Series
- 12 / 30** - Nominal Output Voltage / Maximum Output Current in Amps
- D48** - Input Voltage Range: D48 = 36-75 Volts (48V nominal)
- N** - On/Off Control Polarity: N = Negative polarity, standard; P = Positive polarity, optional
- B** - Baseplate (optional): Blank = No baseplate, standard; B = Baseplate installed, optional quantity order
- H** - Conformal coating (optional): Blank = no coating, standard; H = Coating added, optional, special quantity order
- Lx** - Pin length option: Blank = standard pin length 0.180 in. (4.6 mm); L1 = 0.110 in. (2.79 mm)\*; L2 = 0.145 in. (3.68 mm)\*; \*Special quantity order required
- C** - RoHS Hazardous Materials compliance: C = RoHS-6 (no lead), standard, does not claim EU exemption 7b – lead in solder; Y = RoHS-5 (with lead), optional, special quantity order

**Note:** Some model combinations may not be available. Contact Murata Power Solutions for availability.

Note: Because of the high currents, wire the appropriate input, output and common pins in parallel. Be sure to use adequate PC board etch. If not sufficient, install additional discrete wiring.

### On/Off Enable Control Ground Bounce Protection

To improve reliability, if you use a small signal transistor or other external circuit to select the Remote On/Off control, make sure to return the LO side directly to the -Vin power input on the DC/DC converter. To avoid ground bounce errors, do not connect the On/Off return to a distant ground plane or current-carrying bus. If necessary, run a separate small return wire directly to the -Vin terminal. There is very little current (typically 1-5 mA) on the On/Off control however, large current changes on a return ground plane or ground bus can accidentally trigger the converter on or off. If possible, mount the On/Off transistor or other control circuit adjacent to the converter.

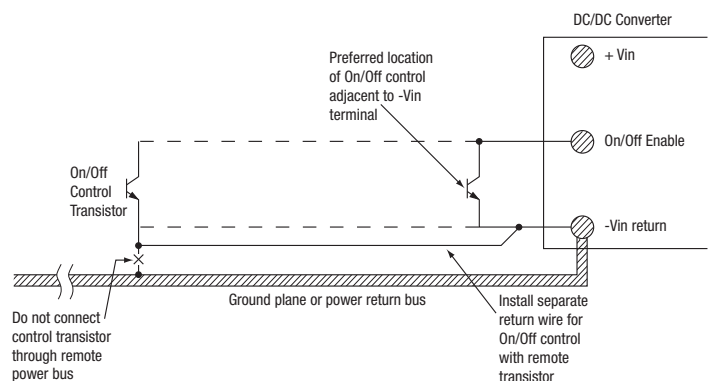
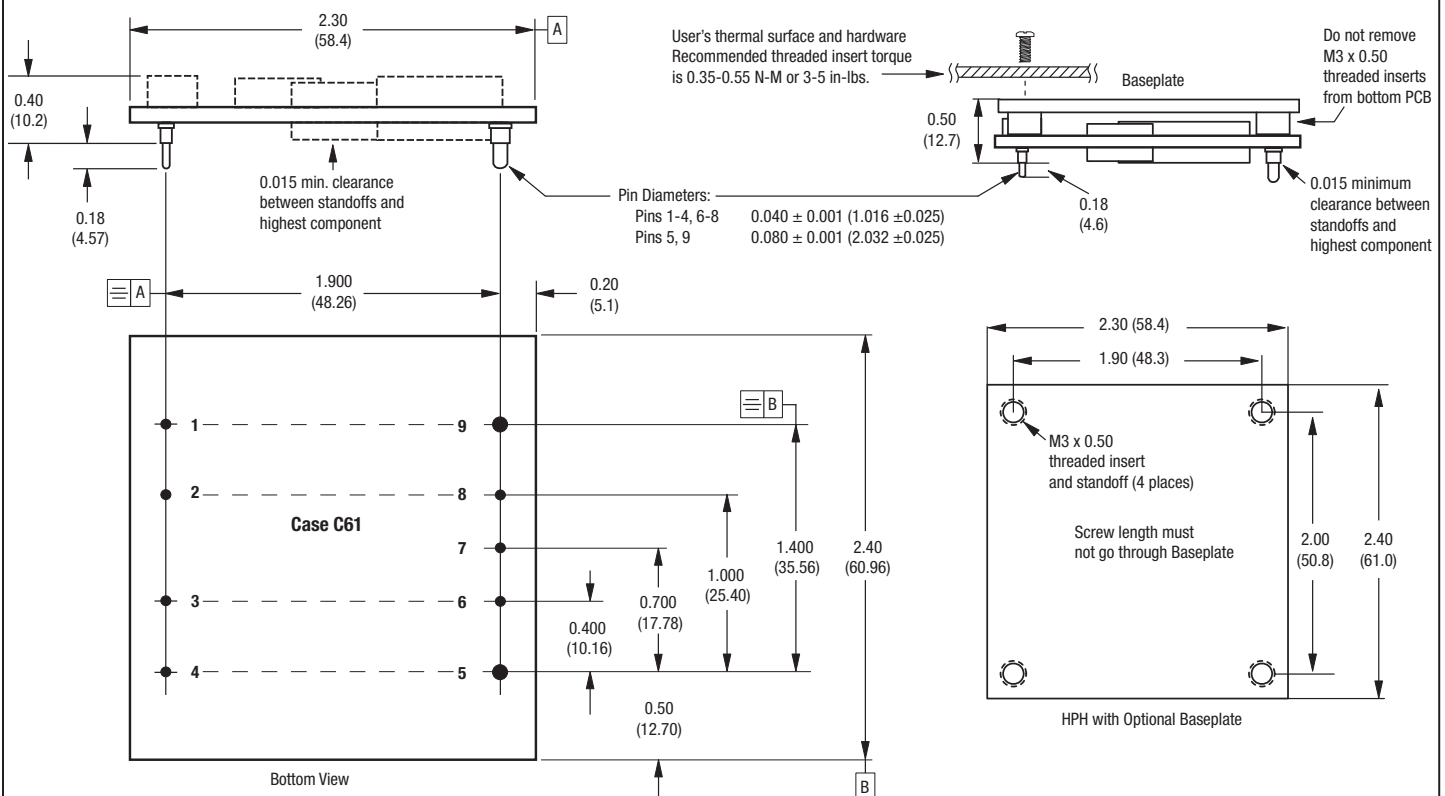
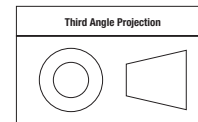

Figure 1 – On/Off Enable Control Ground Bounce Protection

## MECHANICAL SPECIFICATIONS



Dimensions are in inches (mm) shown for ref. only.



Tolerances (unless otherwise specified):  
 .XX ± 0.02 (0.5)  
 .XXX ± 0.010 (0.25)  
 Angles ± 2°

Components are shown for reference only.

### INPUT/OUTPUT CONNECTIONS

Pin	Function P17
1	Negative Input
2	Case*
3	On/Off Control
4	Positive Input
5	Positive Output
6	Positive Sense
7	Trim
8	Negative Sense
9	Negative Output

Pin 2 may be removed under special order. Please contact Murata Power Solutions.

Since there is some pin numbering inconsistency between manufacturers of half brick converters, be sure to follow the pin function, not the pin number, when laying out your board.

Standard pin length is shown. Please refer to the Part Number Structure for special order pin lengths.

\* Note that the "case" connects to the baseplate (when installed). This case connection is isolated from the rest of the converter. Pin 2 may be deleted under special order. Please contact Murata Power Solutions for information.

The Trim connection may be left open and the converter will achieve its rated output voltage.

### FUNCTIONAL SPECIFICATIONS

ABSOLUTE MAXIMUM RATINGS	Conditions ①	Minimum	Typical/Nominal	Maximum	Units
Input Voltage, Continuous	Full power operation	0		75	Vdc
	Ambient temperature range	-40		85	Vdc
Input Voltage, Transient	Operating or non-operating, tested: 100 mS max. duration	0		100	Vdc
Isolation Voltage	Input to output tested 100 mS IEC/EN/UL 60950-1, 2nd Edition			2250	Vdc
Input Reverse Polarity	None, install external fuse		None		Vdc
On/Off Remote Control	Power on or off, referred to -Vin	0		50	Vdc
Output Power		0		450	W
Output Current	Current-limited, no damage, short-circuit protected	0		16	A
Storage Temperature Range	Vin = Zero (no power)	-55		125	°C
Absolute maximums are stress ratings. Exposure of devices to greater than any of these conditions may adversely affect long-term reliability. Proper operation under conditions other than those listed in the Performance/Functional Specifications Table is not implied nor recommended.					
<b>INPUT</b>					
Operating voltage range ②		36	48	75	Vdc
Turn On/Start-up threshold	Rising input voltage	33	34	35	Vdc
Turn Off/Undervoltage lockout	Falling input voltage	31	32	33	Vdc
Reverse Polarity Protection	None, install external fuse		None		Vdc
Recommended External Fuse	Fast blow		20		A
Internal Filter Type			Pi		
<b>Input current</b>					
Full Load Conditions	Vin = nominal		8.06	8.23	A
Low Line	Vin = minimum		10.75	10.98	A
Inrush Transient			0.3		A <sup>2</sup> -Sec.
Output in Short Circuit			50	100	mA
No Load	I <sub>out</sub> = minimum, unit=ON		150	200	mA
Standby Mode (Off, UV, OT)			4	5	mA
Reflected (back) ripple current ③	Measured at input with specified filter		60	100	mA, RMS
<b>GENERAL and SAFETY</b>					
Efficiency	Vin=48V, full load	92	93		%
	Vin=36V, full load	92	93		%
<b>Isolation</b>					
Isolation Voltage: no baseplate	Input to output, continuous	2250			Vdc
Isolation Voltage: with baseplate	Input to output, continuous	TBD			Vdc
	Input to Baseplate, continuous	1500			
	Output to Baseplate, continuous	1500			
Insulation Safety Rating			basic		
Isolation Resistance			100		Mohm
Isolation Capacitance			2,000		pF
Safety (Designed to meet the following requirements)	UL-60950-1, CSA-C22.2 No.60950-1, IEC/EN60950-1, 2nd Edition		Yes		
Calculated MTBF	Per MIL-HDBK-217F Ground benign, Tambient=+30°C		TBD		Hours x 10 <sup>6</sup>
	Per Telcordia SR332, issue 1 class 3, ground fixed, Tambient=+40°C		1.4		Hours x 10 <sup>6</sup>
<b>DYNAMIC CHARACTERISTICS</b>					
Fixed Switching Frequency		350	400	450	KHz
Startup Time	Power On to V <sub>out</sub> regulated 10-90% (50% resistive load)			20	mS
Startup Time	Remote ON to 10% V <sub>out</sub> (50% resistive load)			20	mS
Dynamic Load Response	50-75-50% load step, settling time to within ±1% of V <sub>out</sub> di/dt = 1 A/μSec		200	400	μSec
Dynamic Load Peak Deviation	same as above		±400		mV
<b>FEATURES and OPTIONS</b>					
Remote On/Off Control ④					
"N" suffix:					
Negative Logic, ON state	ON = Pin grounded or external voltage	0		0.8	V
Negative Logic, OFF state	OFF = Pin open or external voltage	3.5		13.5	V
Control Current	open collector/drain		1	2	mA

## FUNCTIONAL SPECIFICATIONS (CONT.)

FEATURES and OPTIONS (cont.)	Conditions ①	Minimum	Typical/Nominal	Maximum	Units
<b>Remote On/Off Control (cont.) ④</b>					
"P" suffix:					
Positive Logic, ON state	ON = Pin open or external voltage	3.5		13.5	V
Positive Logic, OFF state	OFF = Pin grounded or external voltage	0		1	V
Control Current	open collector/drain		1	2	mA
Base Plate	"B" suffix				
<b>OUTPUT</b>					
Total Output Power	See Derating	0.0		360	W
<b>Voltage</b>					
Nominal Output Voltage	No trim	11.88	12.00	12.12	V <sub>dc</sub>
Setting Accuracy	At 50% load	-1		1	% of V <sub>nom.</sub>
Output Voltage Range	User-adjustable [6]	-10		10	% of V <sub>nom.</sub>
Overvoltage Protection	Via magnetic feedback		14.5		V <sub>dc</sub>
<b>Current</b>					
Output Current Range		0		30	A
Minimum Load			No minimum load		
Current Limit Inception ⑤	98% of V <sub>nom.</sub> , after warmup	31.5	37	44	A
<b>Short Circuit</b>					
Short Circuit Current	Hiccup technique, autorecovery within ±1% of V <sub>out</sub> , non-latching		6.6		A
Short Circuit Duration (remove short for recovery)	Output shorted to ground, no damage		Continuous		
Short circuit protection method	Current limiting				
<b>Regulation ⑥</b>					
Line Regulation	V <sub>in</sub> =min. to max. V <sub>out</sub> =nom., 50% load			±0.05	%
Load Regulation	I <sub>out</sub> =min. to max. V <sub>in</sub> =48V.			±0.1	%
Ripple and Noise ⑦	5 Hz - 20 MHz BW		100	200	mV pk-pk
Temperature Coefficient	At all outputs		0.02		% of V <sub>nom.</sub> /°C
Maximum Capacitive Loading (10% ceramic, 90% Oscon)	Cap. ESR=<0.02Ω, Full resistive load	0		10,000	μF
<b>MECHANICAL (Through Hole Models)</b>					
Outline Dimensions (no baseplate)	Cxx case		2.3 X 2.4 X 0.4		Inches
	WxLxH (Please refer to outline drawing)		58.4 X 60.96 X 10.2		mm
Outline Dimensions (with baseplate)			2.3 X 2.4 X 0.5		Inches
			36.8x58.4x12.7		mm
Weight (no baseplate)			TBD		Ounces
			TBD		Grams
Weight (with baseplate)					Ounces
					Grams
Through Hole Pin Diameter					Inches
					mm
Through Hole Pin Material			Copper alloy		
TH Pin Plating Metal and Thickness	Nickel subplate				μ-inches
	Gold overplate				μ-inches
Case or Baseplate Material			Aluminum		
<b>ENVIRONMENTAL</b>					
Operating Ambient Temperature Range	With derating, full power, natural convection, no baseplate	-40		85	°C
Operating Ambient Temperature Range with Baseplate	No derating, with baseplate, full power	-40		120	°C
Storage Temperature	V <sub>in</sub> = Zero (no power)	-55		125	°C
Thermal Protection/Shutdown	Measured at hotspot		120		°C
Electromagnetic Interference Conducted, EN55022/CISPR22	External filter required		B		Class
			B		Class
Relative humidity, non-condensing	To +85°C	10		90	%RH
Altitude (must derate -1%/1000 feet)		-500		10,000	feet
		-152		3048	meters
RoHS rating			RoHS-6 or RoHS-5 (specify)		

## Notes

- ① Unless otherwise noted, all specifications are at nominal input voltage, nominal output voltage and full load. General conditions are +25° Celsius ambient temperature, near sea level altitude, natural convection airflow. All models are tested and specified with external parallel 1  $\mu$ F and 10  $\mu$ F multi-layer ceramic output capacitors. No external input capacitors are installed. All capacitors are low-ESR types wired close to the converter. These capacitors are necessary for our test equipment and may not be needed in the user's application.
- ② The module will operate when input voltage is within the 36-75V Operating Voltage Range, Output regulation at full load will be achieved only when  $V_{in} \geq 39V$
- ③ Input (back) ripple current is tested and specified over 5 Hz to 20 MHz bandwidth. Input filtering is  $C_{bus} = 0 \mu F$ ,  $C_{in} = 100 \mu F$  and  $L_{bus} = < 4.7 \mu H$ .
- ④ The Remote On/Off Control is referred to -Vin.
- ⑤ Over-current protection is non-latching with auto recovery (Hiccup)
- ⑥ Regulation specifications describe the output voltage changes as the line voltage or load current is varied from its nominal or midpoint value to either extreme.
- ⑦ Output Ripple & Noise is measured with 750  $\mu F$  capacitance, 10% ceramic and 90% OSCON. 20 MHz bandwidth.

**APPLICATION NOTES**

**Input Fusing**

Certain applications and/or safety agencies may require fuses at the inputs of power conversion components. Fuses should also be used when there is the possibility of sustained input voltage reversal which is not current-limited. For greatest safety, we recommend a fast blow fuse installed in the ungrounded input supply line.

The installer must observe all relevant safety standards and regulations. For safety agency approvals, install the converter in compliance with the end-user safety standard, i.e. IEC/EN/UL 60950-1.

**Input Reverse-Polarity Protection**

If the input voltage polarity is reversed, an internal diode will become forward biased and likely draw excessive current from the power source. If this source is not current-limited or the circuit appropriately fused, it could cause permanent damage to the converter.

**Input Under-Voltage Shutdown and Start-Up Threshold**

Under normal start-up conditions, converters will not begin to regulate properly until the ramping-up input voltage exceeds and remains at the Start-Up Threshold Voltage (see Specifications). Once operating, converters will not turn off until the input voltage drops below the Under-Voltage Shutdown Limit. Subsequent restart will not occur until the input voltage rises again above the Start-Up Threshold. This built-in hysteresis prevents any unstable on/off operation at a single input voltage.

Users should be aware however of input sources near the Under-Voltage Shutdown whose voltage decays as input current is consumed (such as capacitor inputs), the converter shuts off and then restarts as the external capacitor recharges. Such situations could oscillate. To prevent this, make sure the operating input voltage is well above the UV Shutdown voltage AT ALL TIMES.

**Start-Up Time**

Assuming that the output current is set at the rated maximum, the Vin to Vout Start-Up Time (see Specifications) is the time interval between the point when the ramping input voltage crosses the Start-Up Threshold and the fully loaded regulated output voltage enters and remains within its specified accuracy band. Actual measured times will vary with input source impedance, external input capacitance, input voltage slew rate and final value of the input voltage as it appears at the converter.

These converters include a soft start circuit to moderate the duty cycle of its PWM controller at power up, thereby limiting the input inrush current.

The On/Off Remote Control interval from On command to Vout regulated assumes that the converter already has its input voltage stabilized above the Start-Up Threshold before the On command. The interval is measured from the On command until the output enters and remains within its specified accuracy band. The specification assumes that the output is fully loaded at maximum rated current. Similar conditions apply to the On to Vout regulated specification such as external load capacitance and soft start circuitry.

**Input Source Impedance**

These converters will operate to specifications without external components, assuming that the source voltage has very low impedance and reasonable input voltage regulation. Since real-world voltage sources have finite

impedance, performance is improved by adding external filter components. Sometimes only a small ceramic capacitor is sufficient. Since it is difficult to totally characterize all applications, some experimentation may be needed. Note that external input capacitors must accept high speed switching currents.

Because of the switching nature of DC/DC converters, the input of these converters must be driven from a source with both low AC impedance and adequate DC input regulation. Performance will degrade with increasing input inductance. Excessive input inductance may inhibit operation. The DC input regulation specifies that the input voltage, once operating, must never degrade below the Shut-Down Threshold under all load conditions. Be sure to use adequate trace sizes and mount components close to the converter.

**I/O Filtering, Input Ripple Current and Output Noise**

All models in this converter series are tested and specified for input reflected ripple current and output noise using designated external input/output components, circuits and layout as shown in the figures below. External input capacitors (C<sub>in</sub> in the figure) serve primarily as energy storage elements, minimizing line voltage variations caused by transient IR drops in the input conductors. Users should select input capacitors for bulk capacitance (at appropriate frequencies), low ESR and high RMS ripple current ratings. In the figure below, the C<sub>bus</sub> and L<sub>bus</sub> components simulate a typical DC voltage bus. Your specific system configuration may require additional considerations. Please note that the values of C<sub>in</sub>, L<sub>bus</sub> and C<sub>bus</sub> will vary according to the specific converter model.

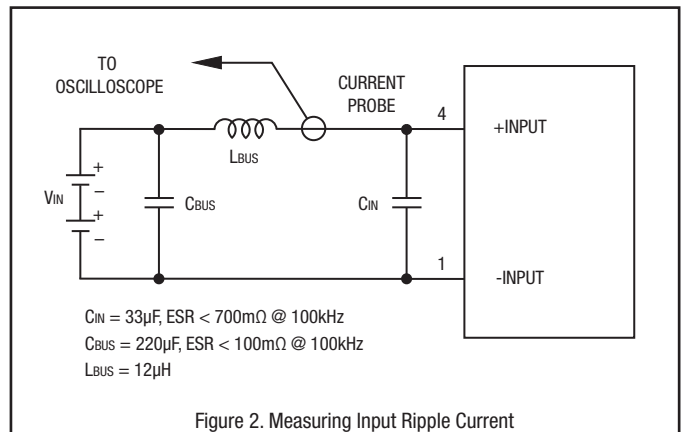

In critical applications, output ripple and noise (also referred to as periodic and random deviations or PARD) may be reduced by adding filter elements such as multiple external capacitors. Be sure to calculate component temperature rise from reflected AC current dissipated inside capacitor ESR. Our Application Engineers can recommend potential solutions.

In figure 3, the two copper strips simulate real-world printed circuit impedances between the power supply and its load. In order to minimize circuit errors and standardize tests between units, scope measurements should be made using BNC connectors or the probe ground should not exceed one half inch and soldered directly to the fixture.



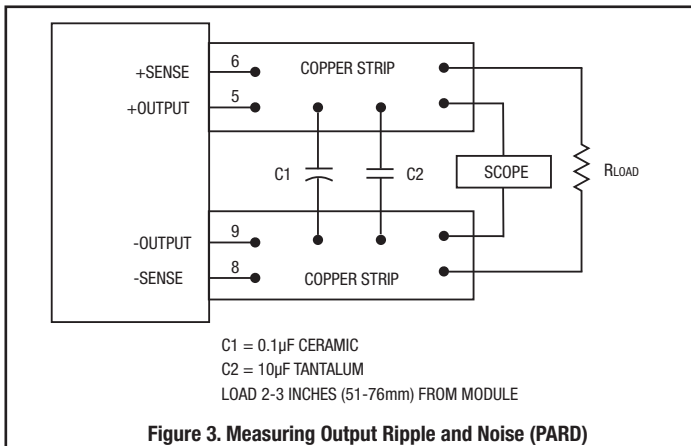

### Floating Outputs

Since these are isolated DC/DC converters, their outputs are “floating” with respect to their input. The essential feature of such isolation is ideal ZERO CURRENT FLOW between input and output. Real-world converters however do exhibit tiny leakage currents between input and output (see Specifications). These leakages consist of both an AC stray capacitance coupling component and a DC leakage resistance. When using the isolation feature, do not allow the isolation voltage to exceed specifications. Otherwise the converter may be damaged. Designers will normally use the negative output (-Output) as the ground return of the load circuit. You can however use the positive output (+Output) as the ground return to effectively reverse the output polarity.

### Minimum Output Loading Requirements

These converters employ a synchronous rectifier design topology. All models regulate within specification and are stable under no load to full load conditions. Operation under no load might however slightly increase output ripple and noise.

### Thermal Shutdown

To prevent many over temperature problems and damage, these converters include thermal shutdown circuitry. If environmental conditions cause the temperature of the DC/DC's to rise above the Operating Temperature Range up to the shutdown temperature, an on-board electronic temperature sensor will power down the unit. When the temperature decreases below the turn-on threshold, the converter will automatically restart. There is a small amount of hysteresis to prevent rapid on/off cycling. The temperature sensor is typically located adjacent to the switching controller, approximately in the center of the unit. See the Performance and Functional Specifications.

**CAUTION:** If you operate too close to the thermal limits, the converter may shut down suddenly without warning. Be sure to thoroughly test your application to avoid unplanned thermal shutdown.

### Temperature Derating Curves

The graphs in the next section illustrate typical operation under a variety of conditions. The Derating curves show the maximum continuous ambient air temperature and decreasing maximum output current which is acceptable under increasing forced airflow measured in Linear Feet per Minute (“LFM”). Note that these are AVERAGE measurements. The converter will accept brief increases in temperature and/or current or reduced airflow as long as the average is not exceeded.

Note that the temperatures are of the ambient airflow, not the converter itself which is obviously running at higher temperature than the outside air. Also note that very low flow rates (below about 25 LFM) are similar to “natural convection”, that is, not using fan-forced airflow.

MPS makes Characterization measurements in a closed cycle wind tunnel with calibrated airflow. We use both thermocouples and an infrared camera system to observe thermal performance. As a practical matter, it is quite difficult to insert an anemometer to precisely measure airflow in most applications. Sometimes it is possible to estimate the effective airflow if you thoroughly understand the enclosure geometry, entry/exit orifice areas and the fan flowrate specifications. If in doubt, contact MPS to discuss placement and measurement techniques of suggested temperature sensors.

**CAUTION:** If you routinely or accidentally exceed these Derating guidelines, the converter may have an unplanned Over Temperature shut down. Also, these graphs are all collected at slightly above Sea Level altitude. Be sure to reduce the derating for higher density altitude.

### Output Overvoltage Protection

This converter monitors its output voltage for an over-voltage condition using an on-board electronic comparator. The signal is optically coupled to the primary side PWM controller. If the output exceeds OVP limits, the sensing circuit will power down the unit, and the output voltage will decrease. After a time-out period, the PWM will automatically attempt to restart, causing the output voltage to ramp up to its rated value. It is not necessary to power down and reset the converter for this automatic OVP-recovery restart.

If the fault condition persists and the output voltage climbs to excessive levels, the OVP circuitry will initiate another shutdown cycle. This on/off cycling is referred to as “hiccup” mode. It safely tests full current rated output voltage without damaging the converter.

### Output Fusing

The converter is extensively protected against current, voltage and temperature extremes. However your output application circuit may need additional protection. In the extremely unlikely event of output circuit failure, excessive voltage could be applied to your circuit. Consider using an appropriate fuse in series with the output.

### Output Current Limiting

As soon as the output current increases to its maximum rated value, the DC/DC converter will enter a current-limiting mode. The output voltage will decrease proportionally with increases in output current, thereby maintaining a somewhat constant power output. This is commonly referred to as power limiting.

Current limiting inception is defined as the point at which full power falls below the rated tolerance. See the Performance/Functional Specifications. Note particularly that the output current may briefly rise above its rated value. This enhances reliability and continued operation of your application. If the output current is too high, the converter will enter the short circuit condition.

### Output Short Circuit Condition

When a converter is in current-limit mode, the output voltage will drop as the output current demand increases. If the output voltage drops too low, the magnetically coupled voltage used to develop primary side voltages will also drop, thereby shutting down the PWM controller. Following a time-out period, the PWM will restart, causing the output voltage to begin ramping up to its



appropriate value. If the short-circuit condition persists, another shutdown cycle will initiate. This on/off cycling is called “hiccup mode”. The hiccup cycling reduces the average output current, thereby preventing excessive internal temperatures. A short circuit can be tolerated indefinitely.

### Remote Sense Input

Sense inputs compensate for output voltage inaccuracy delivered at the load. This is done by correcting voltage drops along the output wiring such as moderate IR drops and the current carrying capacity of PC board etch. Sense inputs also improve the stability of the converter and load system by optimizing the control loop phase margin.

Note: The Sense input and power V<sub>out</sub> lines are internally connected through low value resistors to their respective polarities so that the converter can operate without external connection to the Sense. Nevertheless, if the Sense function is not used for remote regulation, the user should connect +Sense to +V<sub>out</sub> and -Sense to -V<sub>out</sub> at the converter pins.

The remote Sense lines carry very little current. They are also capacitively coupled to the output lines and therefore are in the feedback control loop to regulate and stabilize the output. As such, they are not low impedance inputs and must be treated with care in PC board layouts. Sense lines on the PCB should run adjacent to DC signals, preferably Ground. In cables and discrete wiring, use twisted pair, shielded tubing or similar techniques.

Please observe Sense inputs tolerance to avoid improper operation:

$$[V_{out(+)} - V_{out(-)}] - [Sense(+)- Sense(-)] \leq 10\% \text{ of } V_{out}$$

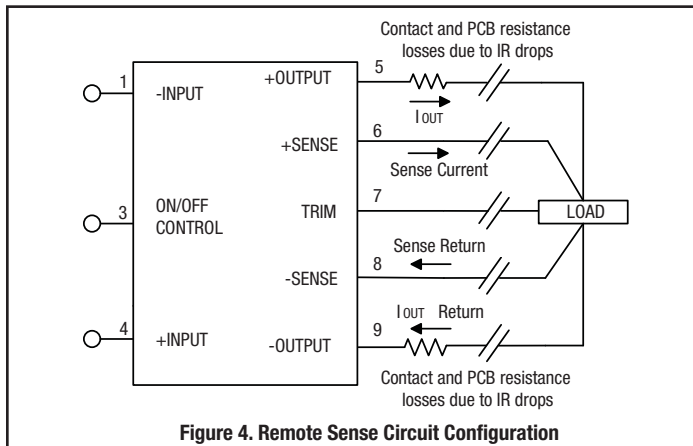

**Figure 4. Remote Sense Circuit Configuration**

Output overvoltage protection is monitored at the output voltage pin, not the Sense pin. Therefore excessive voltage differences between V<sub>out</sub> and Sense together with trim adjustment of the output can cause the overvoltage protection circuit to activate and shut down the output.

Power derating of the converter is based on the combination of maximum output current and the highest output voltage. Therefore the designer must insure:

$$(V_{out \text{ at pins}}) \times (I_{out}) \leq (\text{Max. rated output power})$$

### Trimming the Output Voltage

The Trim input to the converter allows the user to adjust the output voltage over the rated trim range (please refer to the Specifications). In the trim equations and circuit diagrams that follow, trim adjustments use either a trimpot or

a single fixed resistor connected between the Trim input and either the +Sense or -Sense terminals. (On some converters, an external user-supplied precision DC voltage may also be used for trimming). Trimming resistors should have a low temperature coefficient ( $\pm 100$  ppm/deg.C or less) and be mounted close to the converter. Keep leads short. If the trim function is not used, leave the trim unconnected. With no trim, the converter will exhibit its specified output voltage accuracy.

There are two CAUTION's to be aware for the Trim input:

**CAUTION:** To avoid unplanned power down cycles, do not exceed EITHER the maximum output voltage OR the maximum output power when setting the trim. Be particularly careful with a trimpot. If the output voltage is excessive, the OVP circuit may inadvertently shut down the converter. If the maximum power is exceeded, the converter may enter current limiting. If the power is exceeded for an extended period, the converter may overheat and encounter overtemperature shut down.

**CAUTION:** Be careful of external electrical noise. The Trim input is a sensitive input to the converter's feedback control loop. Excessive electrical noise may cause instability or oscillation. Keep external connections short to the Trim input. Use shielding if needed. Also consider adding a small value ceramic capacitor between the Trim and -V<sub>out</sub> to bypass RF and electrical noise.

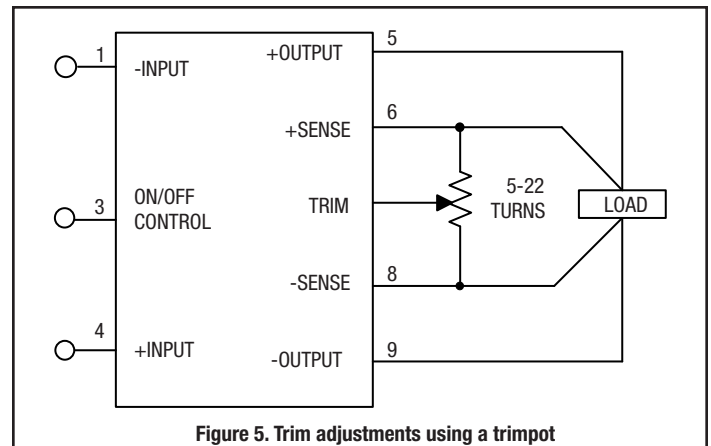

**Figure 5. Trim adjustments using a trimpot**

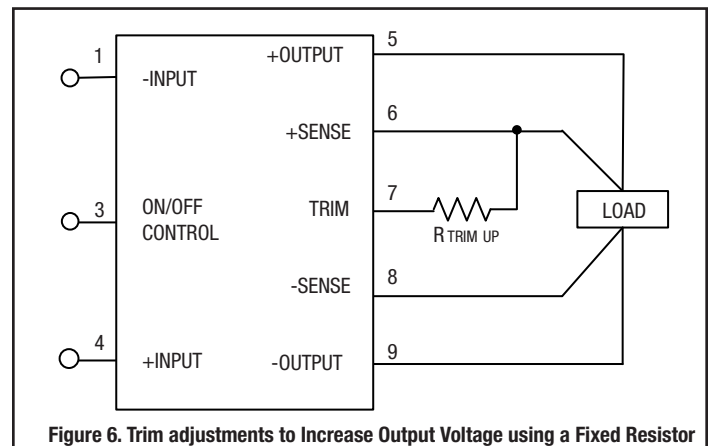

**Figure 6. Trim adjustments to Increase Output Voltage using a Fixed Resistor**

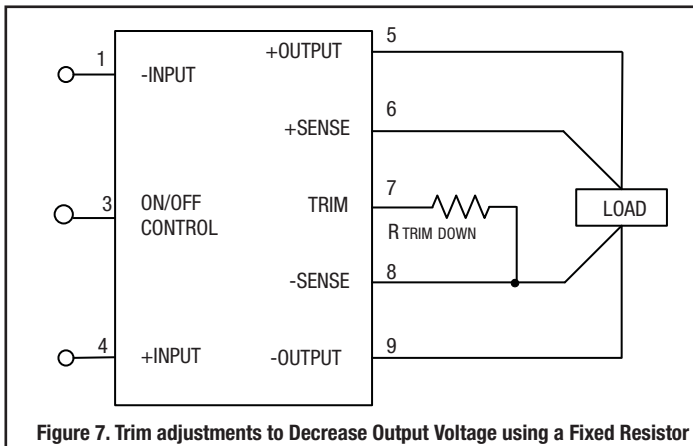

Figure 7. Trim adjustments to Decrease Output Voltage using a Fixed Resistor

$$R_{adj\_up} \text{ (in } k\Omega) = \frac{V_{nominal} \times (1 + \Delta)}{1.225 \times \Delta} - \frac{1}{\Delta} - 2$$

where  $\Delta = \frac{V_{out} - V_{nominal}}{V_{nominal}}$

$$R_{adj\_down} \text{ (in } k\Omega) = \frac{1}{\Delta} - 2$$

where  $\Delta = \frac{V_{nominal} - V_{out}}{V_{nominal}}$

### Trim Equations

Where Vref = +1.225 Volts and Δ is the desired output voltage change. Note that "Δ" is given as a small fraction, not a percentage.

A single resistor connected between Trim and +Sense will increase the output voltage. A resistor connected between Trim and –Sense will decrease the output.

### Remote On/Off Control

On the input side, a remote On/Off Control can be ordered with either polarity.

**Positive:** Standard models are enabled when the On/Off pin is left open or is pulled high to +Vin with respect to –Vin. An internal bias current causes the open pin to rise to +Vin. Some models will also turn on at lower intermediate voltages (see Specifications). Positive-polarity devices are disabled when the On/Off is grounded or brought to within a low voltage (see Specifications) with respect to –Vin.

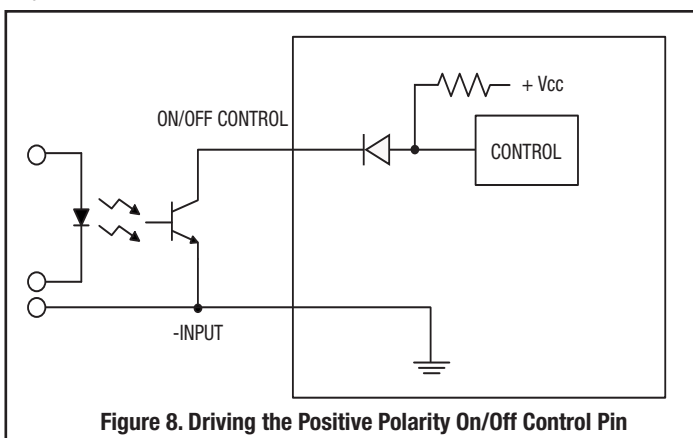

Figure 8. Driving the Positive Polarity On/Off Control Pin

**Negative:** Optional negative-polarity devices are on (enabled) when the On/Off is grounded or brought to within a low voltage (see Specifications) with respect to –Vin. The device is off (disabled) when the On/Off is pulled high to +Vin with respect to –Vin.

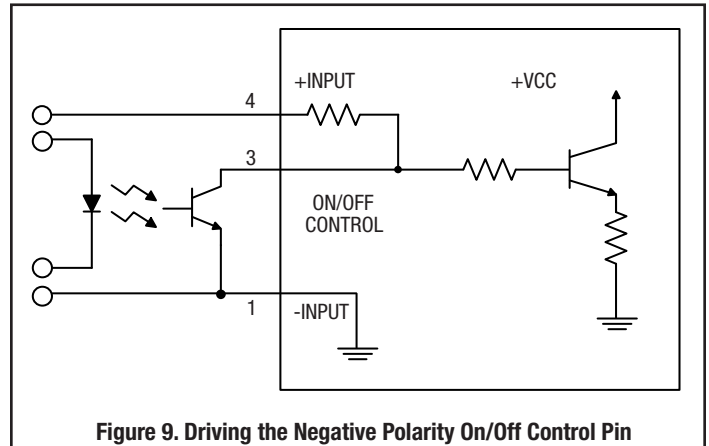

Figure 9. Driving the Negative Polarity On/Off Control Pin

Dynamic control of the On/Off function should be able to sink appropriate signal current when brought low and withstand appropriate voltage when brought high. Be aware too that there is a finite time in milliseconds (see Specifications) between the time of On/Off Control activation and stable, regulated output. This time will vary slightly with output load type and current and input conditions.

There are two CAUTIONS for the On/Off Control:

**CAUTION:** While it is possible to control the On/Off with external logic if you carefully observe the voltage levels, the preferred circuit is either an open drain/open collector transistor or a relay (which can thereupon be controlled by logic).

**CAUTION:** Do not apply voltages to the On/Off pin when there is no input power voltage. Otherwise the converter may be permanently damaged.

### Soldering Guidelines

Murata Power Solutions recommends the specifications below when installing these converters. These specifications vary depending on the solder type. Exceeding these specifications may cause damage to the product. Your production environment may differ; therefore please thoroughly review these guidelines with your process engineers.

Wave Solder Operations for through-hole mounted products (THMT)			
For Sn/Ag/Cu based solders:		For Sn/Pb based solders:	
Maximum Preheat Temperature	115° C.	Maximum Preheat Temperature	105° C.
Maximum Pot Temperature	270° C.	Maximum Pot Temperature	250° C.
Maximum Solder Dwell Time	7 seconds	Maximum Solder Dwell Time	6 seconds

## TYPICAL PERFORMANCE DATA

### Stepload Transient Response

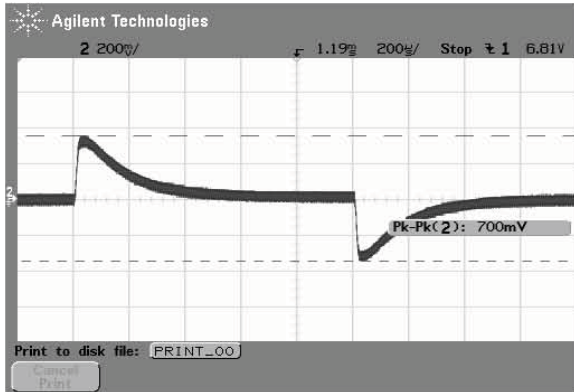

Figure 10. Transient Response (Load 50% to 75%)

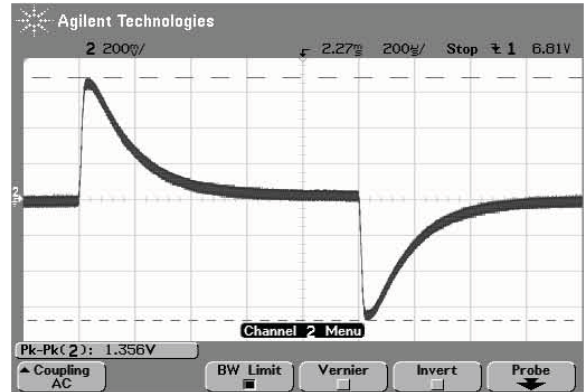

Figure 11. Transient Response (Load 50% to 100%)

### On/Off Enable Start-up

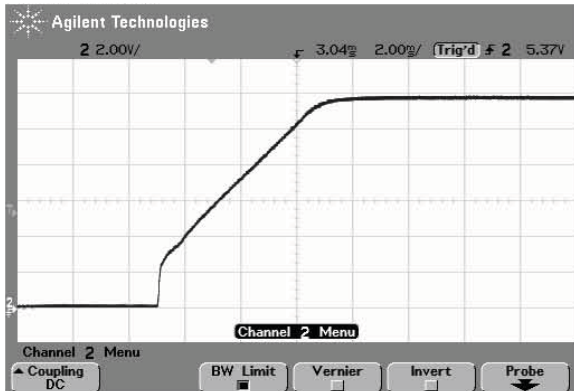

Figure 12. Enable Start-up (Vin=48V Iout=30A)

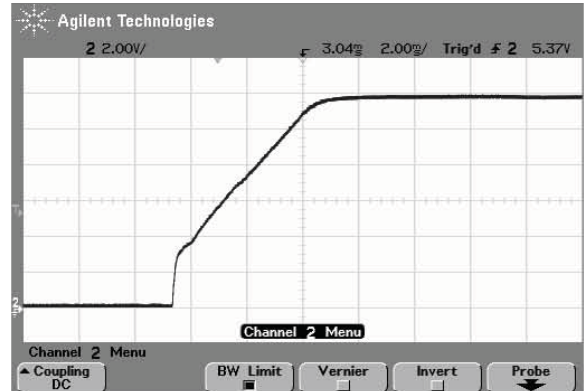

Figure 13. Enable Start-up (Vin=48V Iout=0A)

### Ripple and Noise

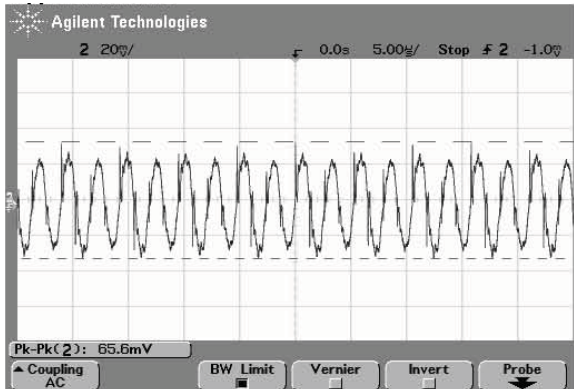

Figure 14. Ripple and Noise Waveform (Vin=48V Iout=30A)

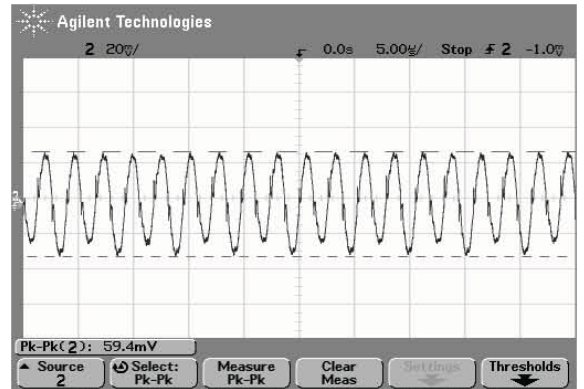
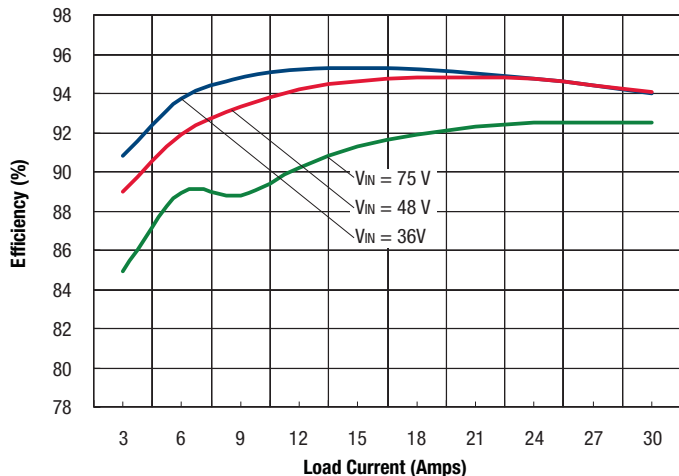

Figure 15. Ripple and Noise Waveform (Vin=48V Iout=0A)

**TYPICAL PERFORMANCE DATA**

Efficiency vs Line Voltage and Load Current @ +25°C



Maximum Current Temperature Derating vs. Airflow  
(Vin=48V., airflow direction is from -Vin to +Vin, no baseplate)

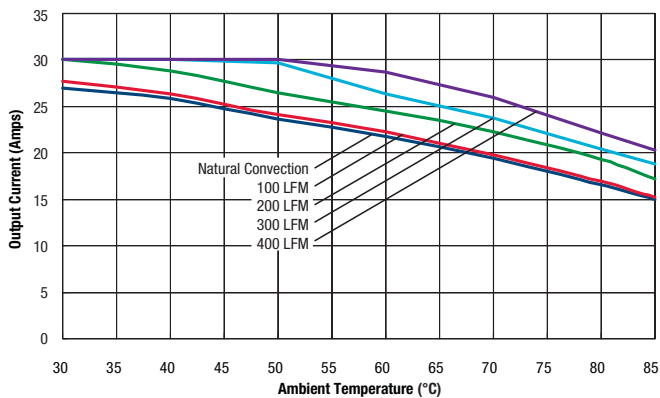

Maximum Current Temperature Derating vs. Airflow  
(Vin=48V., airflow direction is from -Vin to +Vin, with baseplate)

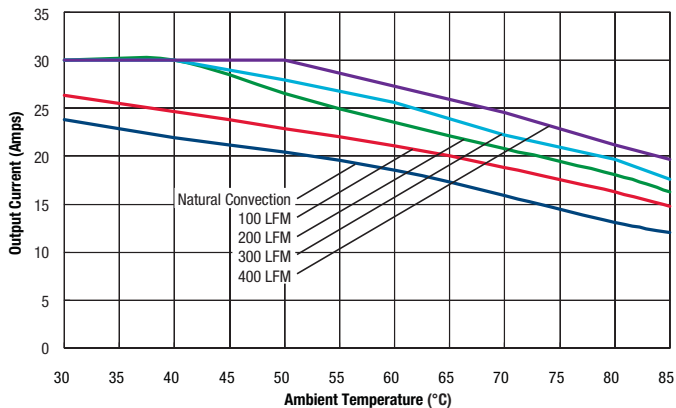

Maximum Current Temperature Derating vs. Airflow  
(Vin=48V., airflow direction is from Vin to Vout, with baseplate)

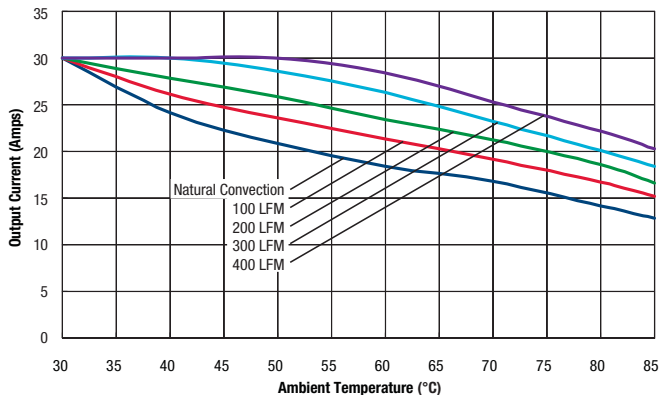

Murata Power Solutions, Inc.  
11 Cabot Boulevard, Mansfield, MA 02048-1151 U.S.A.  
ISO 9001 and 14001 REGISTERED

Murata Power Solutions, Inc. makes no representation that the use of its products in the circuits described herein, or the use of other technical information contained herein, will not infringe upon existing or future patent rights. The descriptions contained herein do not imply the granting of licenses to make, use, or sell equipment constructed in accordance therewith. Specifications are subject to change without notice. © 2010 Murata Power Solutions, Inc.

