

Projet 10 - H2Q / Hacheur 2 quadrants 60V/10A

Projet : IUT3

Info : [DIV414]

Révision : H2Qa – rev. 1 du 15 octobre 2003

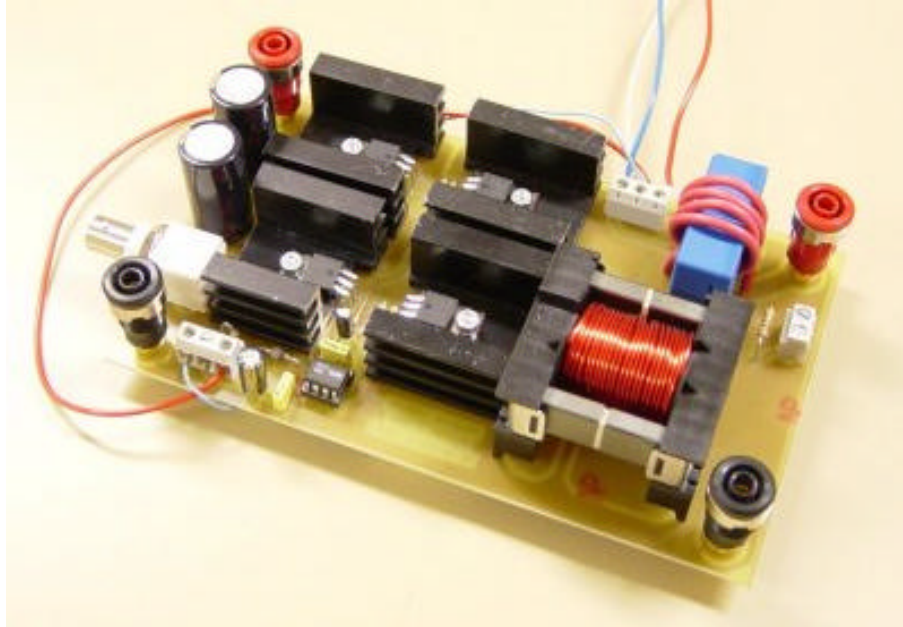

Figure 10.1. Maquette H2Qa (images-maquettes\h2qa-22.jpg).

Révision : H2Qb – rev. 1 du 18 octobre 2003

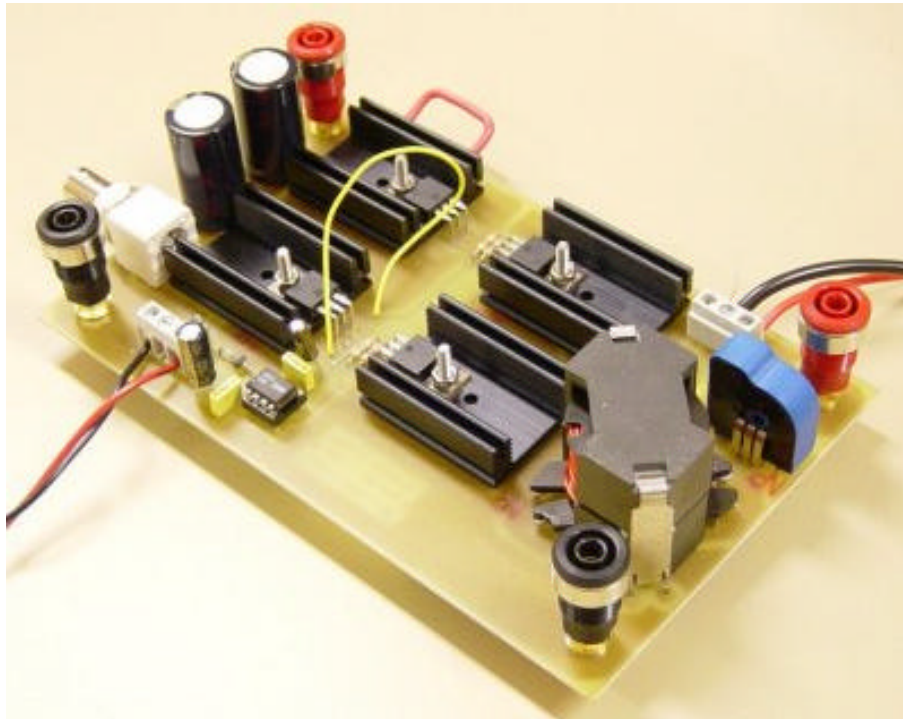

Figure 10.2. Maquette H2Qb (images-maquettes\h2qb-32.jpg).

10.1 Désignation des composants H2Qa

Tableau 10.1. Liste de composants (projets-iut3.xls / H2Qa).

N°	Quantité	Référence	Désignation	Empreinte
1	2	B1,B3	HEADER 1	EMBASE
2	1	B2	OUT	EMBASE
3	1	B4	MASSE	EMBASE
4	2	C4,C1	330uF 100V	RADIAL16
5	3	C2,C7,C8	100nF	CK06
6	1	C5	120uF 25V	RADIAL06L
7	1	C6	10uF 25V	RADIAL06L
8	2	D1,D2	MBR20100CTP	TO220-KL224-38
9	1	D3	BYV95A	DO41
10	1	JP1	COURANT	03PL2
11	1	JP3	CDE	03PL2
12	1	JP4	CDE	BNC1
13	1	LEM1	LTS25-NP	LTS25
14	1	L1	500uH 10A	RM14
15	2	Q1,Q2	IRF540N	TO220-KL224-38
16	2	R1,R3	75	RC04
17	2	R2,R4	1k	RC04
18	1	R6	4.7k	RC02
19	1	U1	IR2111	08DIP300L

10.2 Chronogrammes H2Qa (ETB39 – e = 1mm)

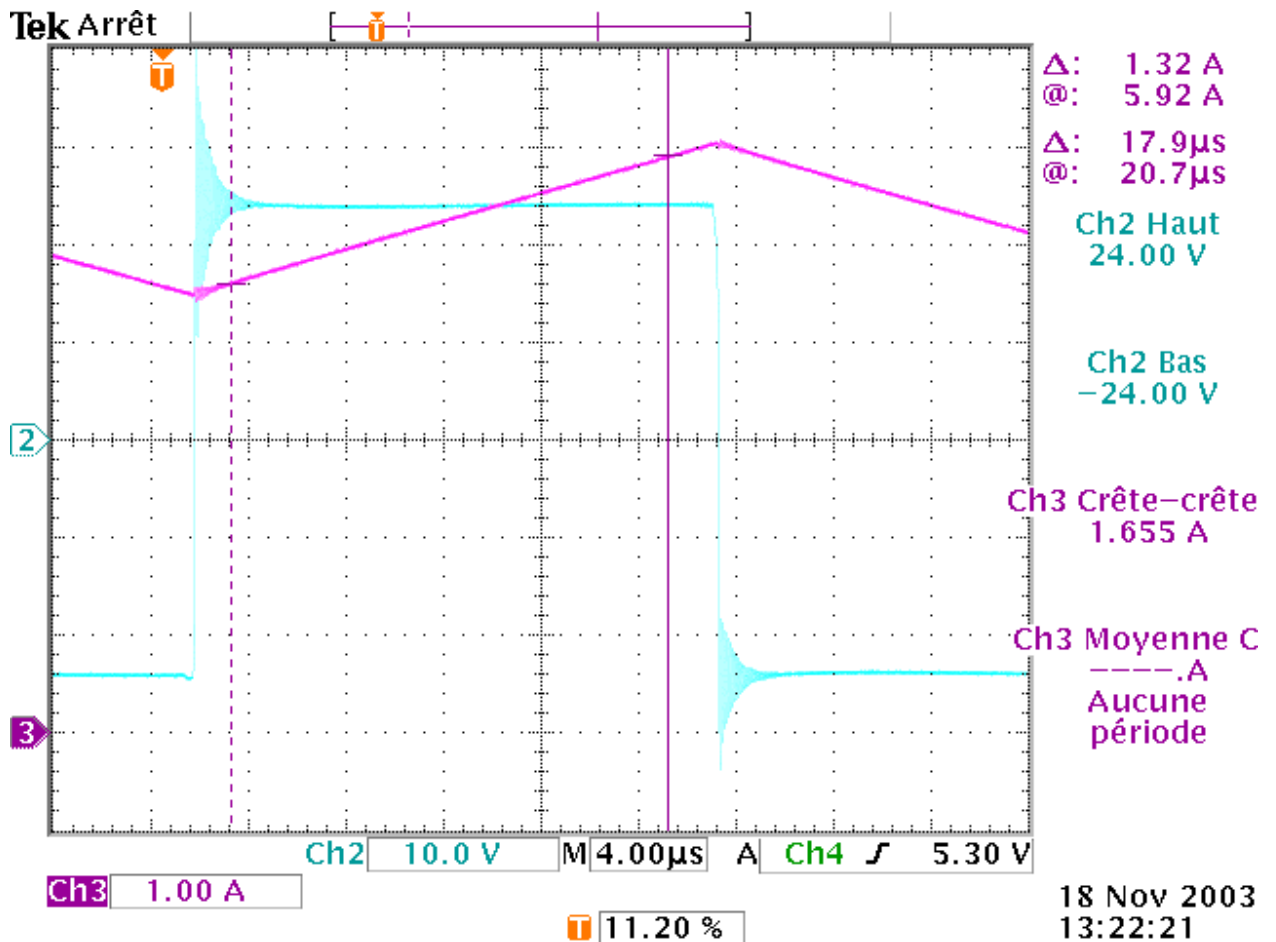

Fig. 10.3. Courant et tension de l'inductance (tektronix\h2qa\0VL-IL-ETD39-1mm.pcx).

Essais	: hacheur de type BUCK
Tension d'entrée	: E = 50 V
Rapport cyclique	: $\alpha = 50 \%$
Courant d'entrée	: $I_e = 2,5 \text{ A}$
Courant de sortie	: $I_s = 5 \text{ A}$
Tension inductance	: $V_{L_{\max}} = +24 \text{ V}$ pendant $\Delta T = 17,9 \mu\text{s}$
Variation du courant	: $\Delta I_L = 1,32 \text{ A}$
Inductance	: $v = L \frac{di}{dt}$ soit $L = \frac{V_L \times \Delta T}{\Delta I_L} = 325 \mu\text{H}$.

Circuit ETD39 – Matériaux 3C90 – Entrefer e = 1 m (FR4) – N = 57 spires – Fils 2 x AWG19 (ϕ 1 mm)

$$\mu_e = 1900 - Ae = 125 \text{ mm}^2 - Le = 92,2 \text{ mm} - \mu_0 = 4 \cdot \pi \cdot 10^{-7}$$

$$L = N^2 \cdot \frac{\mu_0 \cdot \mu_e \cdot Ae}{Le} \cdot \frac{1}{1 + \frac{2 \cdot e \cdot \mu_e}{Le}} = 249 \mu\text{H}$$

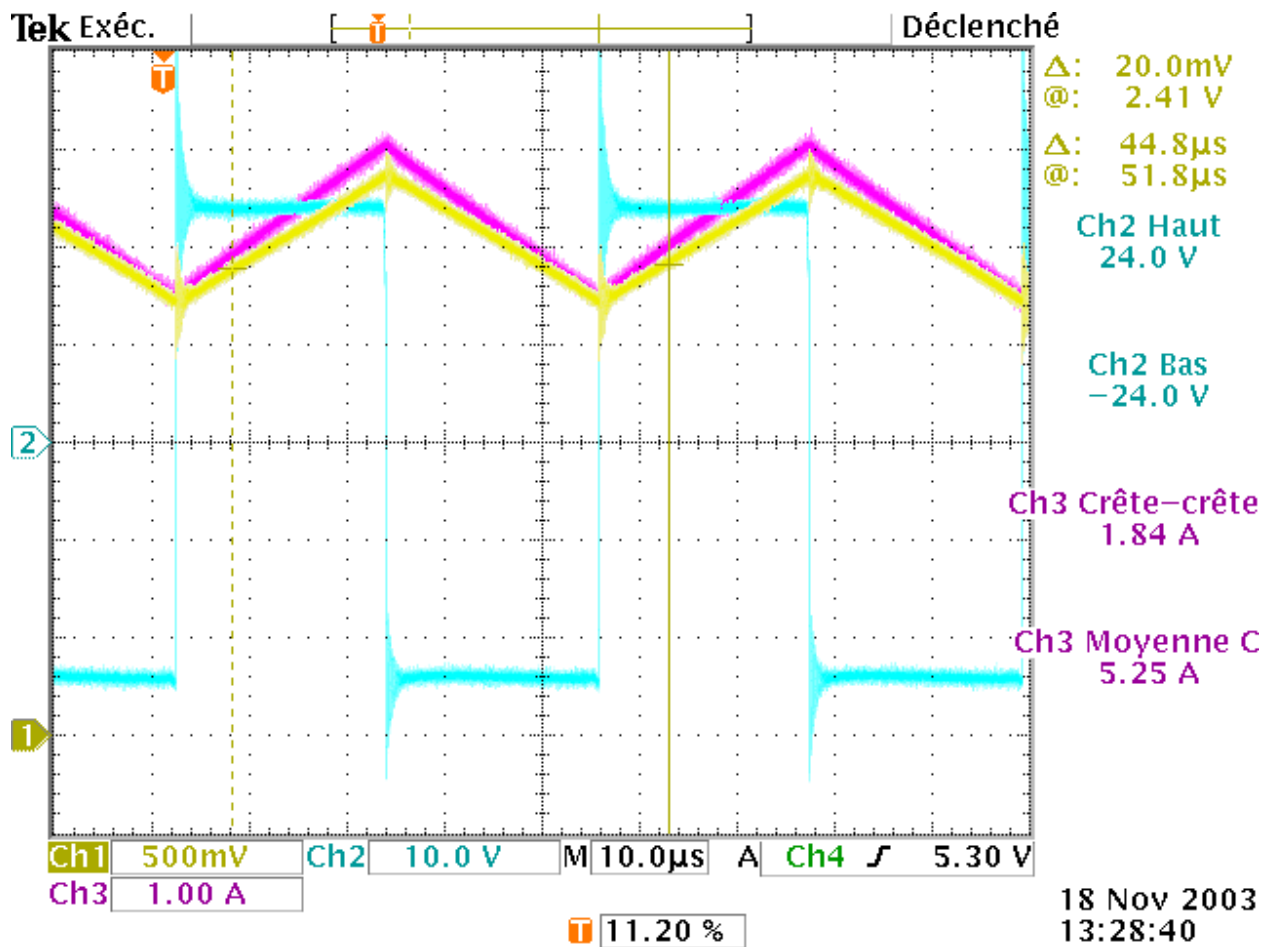

Fig. 10.4. Tension de sortie du capteur de courant (tektronix\h2qa\VL-IL-LA55-100.pcx).

Capteur LEM LA55-P – 5 tours – $R_{mesure} = 100 \Omega$.

$$\Delta I_L = 1,4 \text{ A} - \Delta V_{Imes} = 700 \text{ mV} - \frac{\Delta V}{\Delta I} = \frac{700 \text{ mV}}{1,4 \text{ A}} = 0,5$$

$$V_{OUT} = \frac{N_s \cdot i_p}{1000} \times R_{mes} = \frac{i_p}{200} \times 100 \Omega - \frac{\Delta V}{\Delta I} = \frac{100 \Omega}{200} = 0,5$$

$$V_{OUT} = \frac{N_s \cdot i_p}{1000} \times R_{mes} = i_p \frac{5}{1000} \times 100 \Omega \Rightarrow 0,5 \text{ V/A}$$

10.6 Allure des principaux composants



Fig. 10.10. Bornier CANDEM 3 points (images-composants\bornier1.jpg).

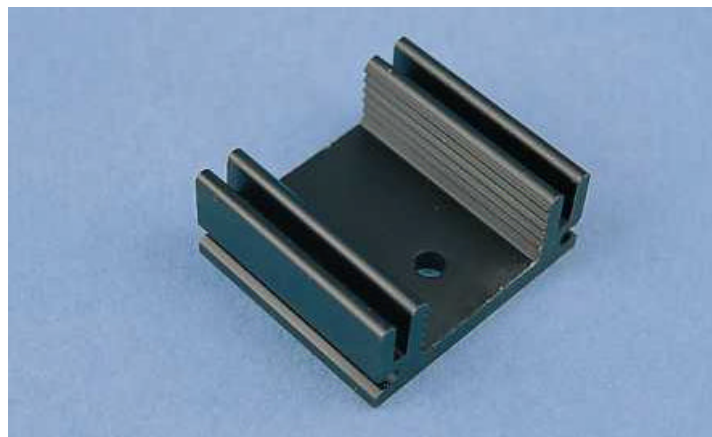

Fig. 10.11. Dissipateur KL-224 (images-composants\kl-224.jpg).

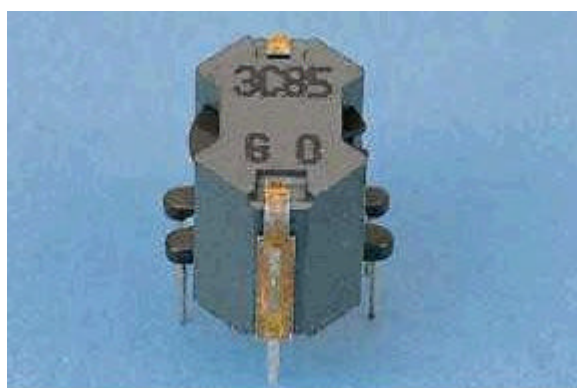

Fig. 10.12. Circuit magnétique (images-composants\rm10.jpg).



Fig. 10.13. Embases filetées (images-composants\embases.gif).

Hacheur 2 quadrants 60V 10A
Revised: Wednesday, October 15, 2003
Projet IUT3 / [DIV414] / H2Qb Revision: 1

1 euro #####

Référence	Qu	Désignation	Fournisseur	Date	Code Cde	U.d.V.	Prix U	Prix T.	
B1, B2	2	Embase mm à visser RO	Radiospares	octobre-03	230-6344	1	, €	, €	43,95 F
B3, B4	2	Embase mm à visser NO	Radiospares	octobre-03	230-6350	1	, €	, €	43,95 F
C4,C1	2	330uF 100V	Radiospares	octobre-03	315-1094	5	#####	, €	29,23 F
C2,C7,C8	3	100nF	Radiospares	octobre-03	166-8433 315-	10	, €	, €	3,54 F
C5	1	120uF 25V	Radiospares	octobre-03	0546	5	, €	, €	1,59 F
C6	1	10uF 25V	Radiospares	octobre-03	315-0805	5	, €	, €	1,25 F
D1,D2	2	MBR20100CTP	Radiospares	octobre-03	447-3351	1	, €	, €	129,35 F
D3	1	BYV95A	Radiospares	octobre-03	196-1007 446-	5	, €	, €	2,23 F
JP1, JP3	2	Bornier plots à visser	Radiospares	octobre-03	7234	5	, €	, €	6,03 F
JP4	1	BNC ohms coudée pou	Radiospares	octobre-03	477-090	1	, €	, €	21,97 F
LEM1	1	LTS25-NP	Radiospares	octobre-03	301-0472 305-	1	#####	, €	118,79 F
L1	1	POT RM14/I-3C90	Farnell	octobre-03	6867	1	, €	, €	38,05 F
L1	1	Bobine RM14	Farnell	octobre-03	200-657	1	, €	, €	24,93 F
L1	1	Clips pour pot RM14	Farnell	octobre-03	291-432	1	, €	, €	3,35 F
L1	6	Fils de cuivre AWG 19	Radiospares	octobre-03	357-788	80	#####	, €	4,93 F
Q1,Q2	2	IRF540N	Radiospares	octobre-03	244-0526	1	, €	, €	43,29 F
R1,R3	2	75	IUT GEII	octobre-03	résistanc	1	, €	, €	0,13 F
R2,R4	2	1k	IUT GEII	octobre-03	résistanc	1	, €	, €	0,13 F
R6	1	4.7k	IUT GEII	octobre-03	résistanc	1	, €	, €	0,07 F
U1	1	IR2111	Radiospares	octobre-03	189-0501	1	, €	, €	56,94 F
Divers	4	Dissipateurs KL-224, 38	Radiospares	octobre-03	218-2255	1	, €	, €	49,59 F
Divers	4	Vis CTF M3x20	Radiospares	octobre-03	560-798	100	, €	, €	0,76 F
Divers	4	Écroux M3	Radiospares	octobre-03	560-293	250	, €	, €	0,48 F
Divers	4	Rondelles frein M3	Radiospares	octobre-03	526-574	250	, €	, €	0,22 F
Divers	1	Support tulipe 8 broches	Radiospares	octobre-03	100-9935	10	, €	, €	2,83 F
Divers	##	Circuit imprimé x	IUT GEII	octobre-03	CI	600	#####	, €	25,90 F

TOTAL H.T. :	, €	653,46 F
#####	, €	134,61 F
TOTAL T.T.C. :	, €	788,08 F

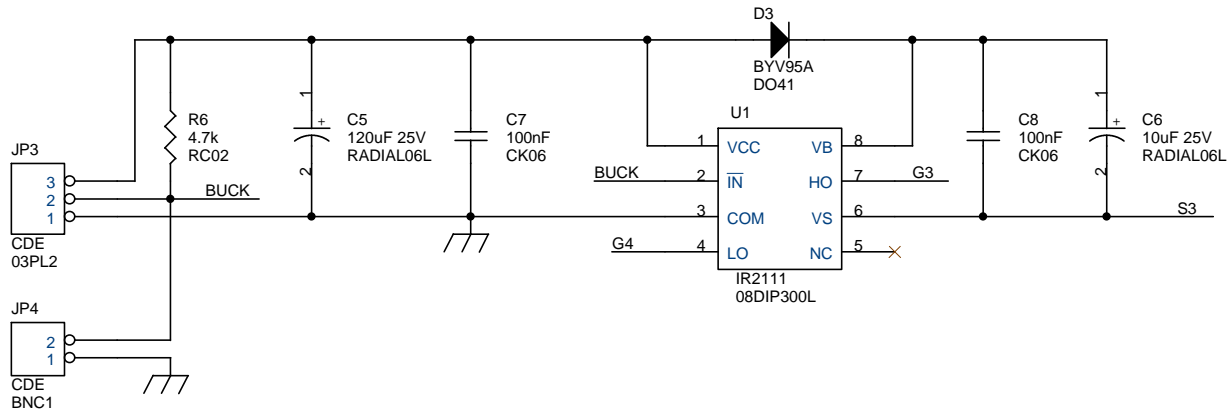
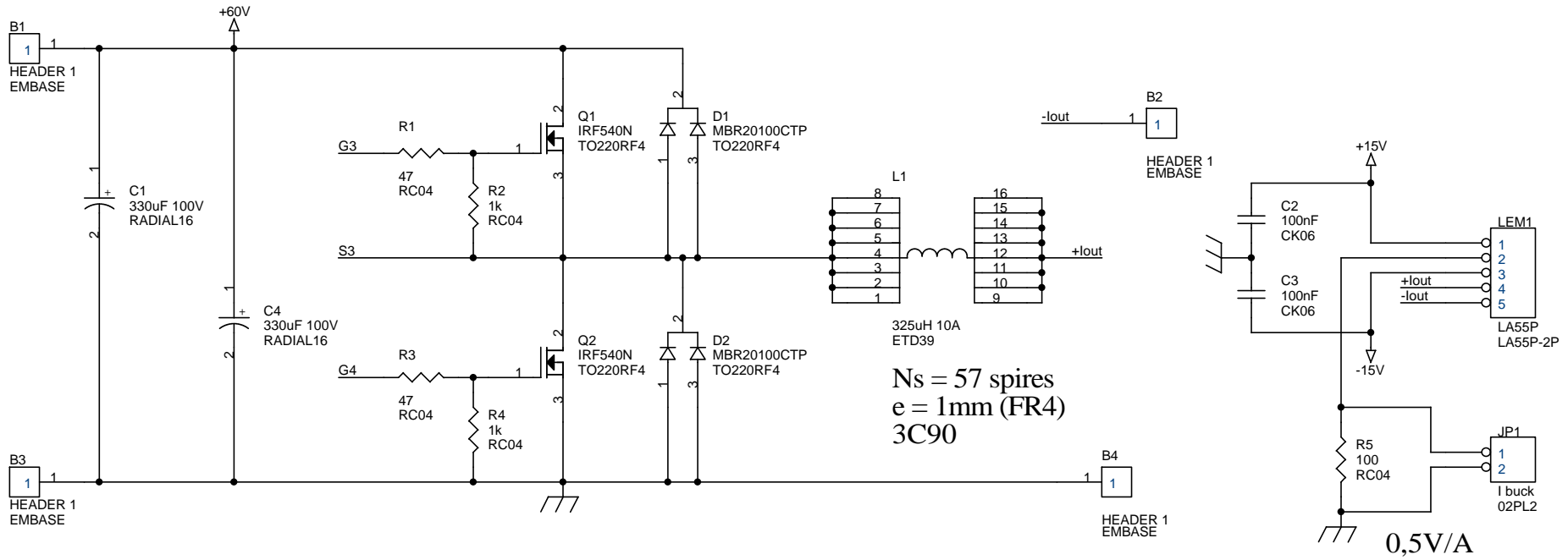

Title		
Hacheur 2 qudarants 60V 10A		
Size A4	Document Number	Rev 1
Projet IUT3 / [DIV414] / H2Q		
Date: Tuesday, November 18, 2003	Sheet 1 of 1	

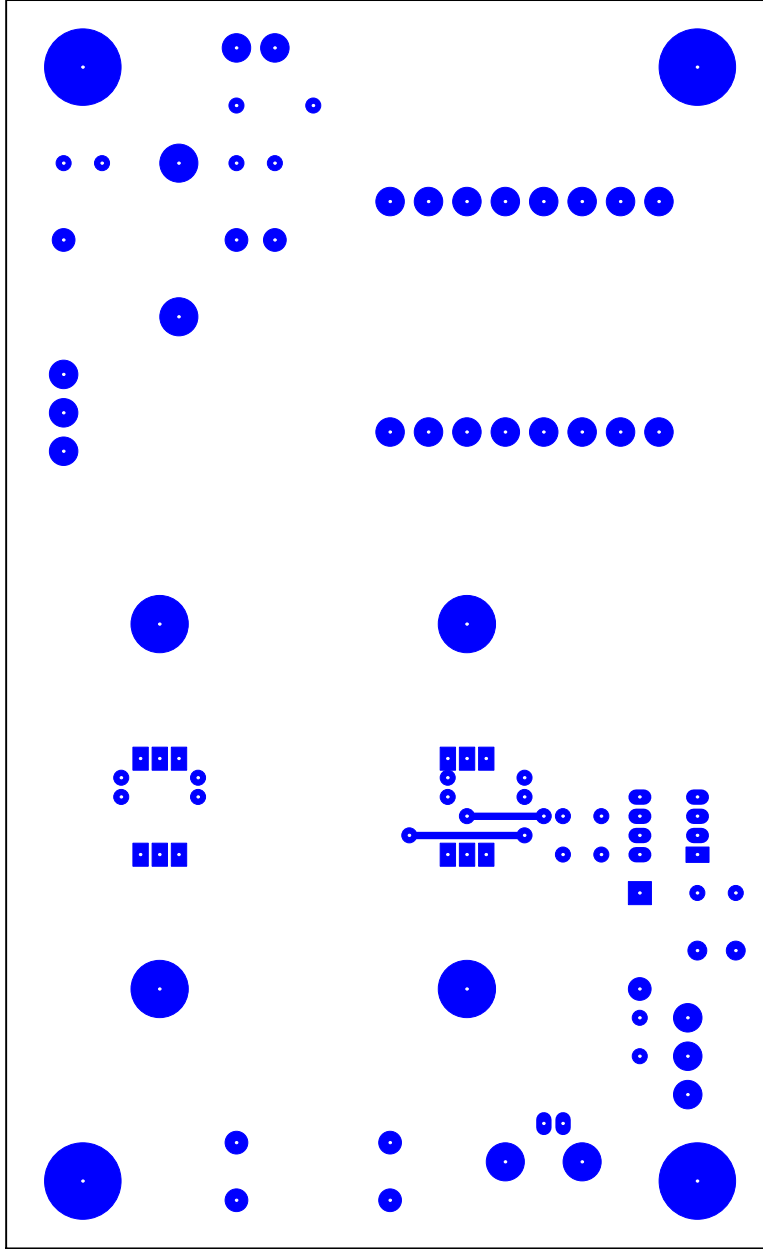

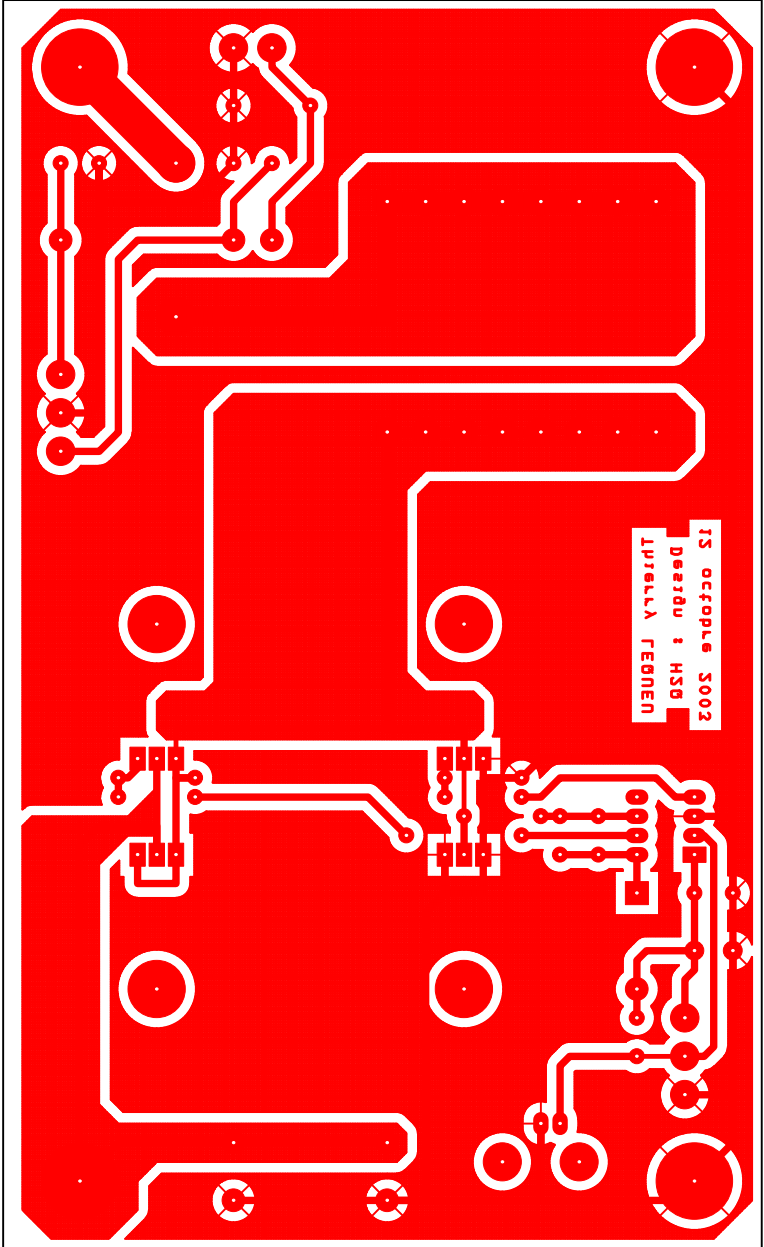

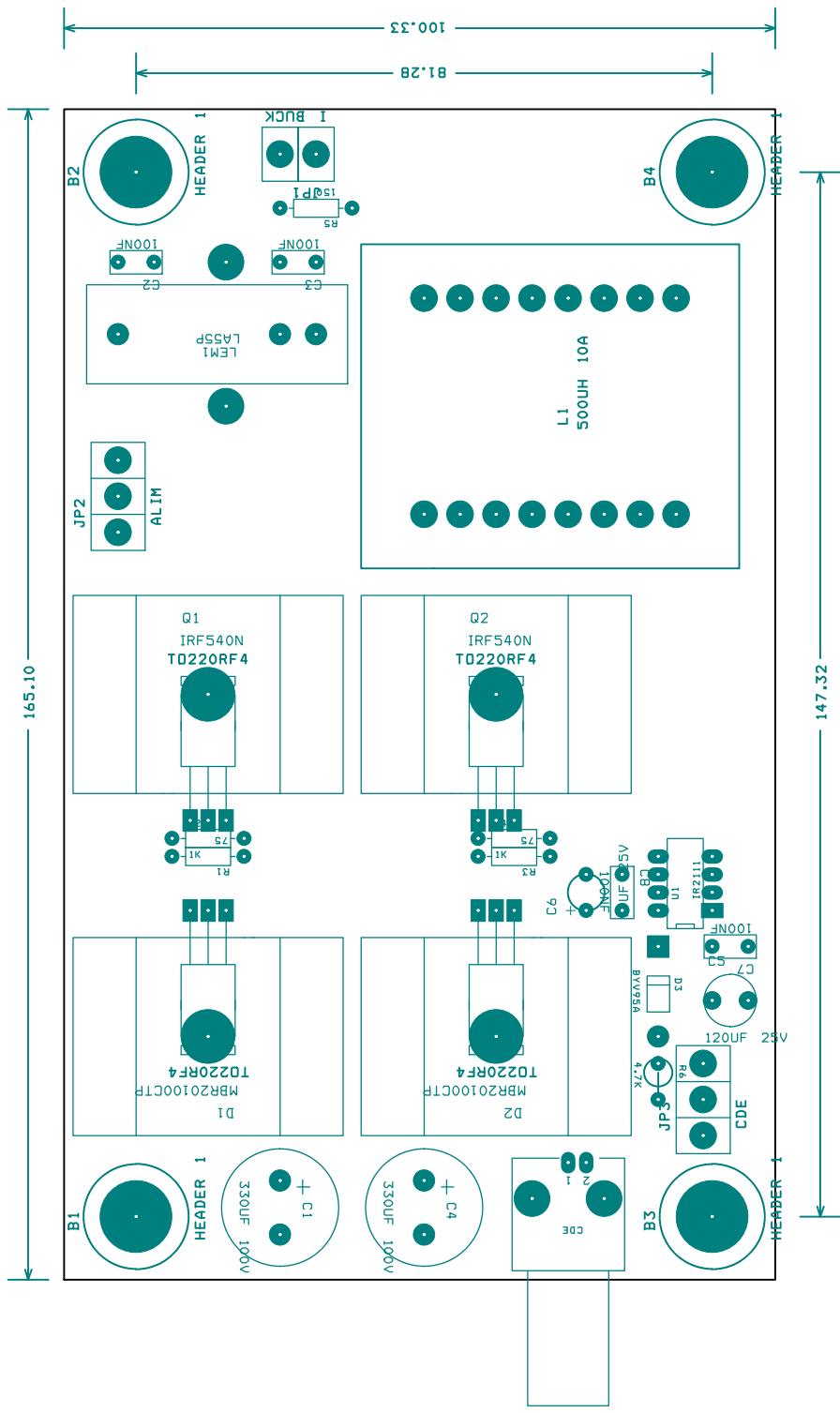

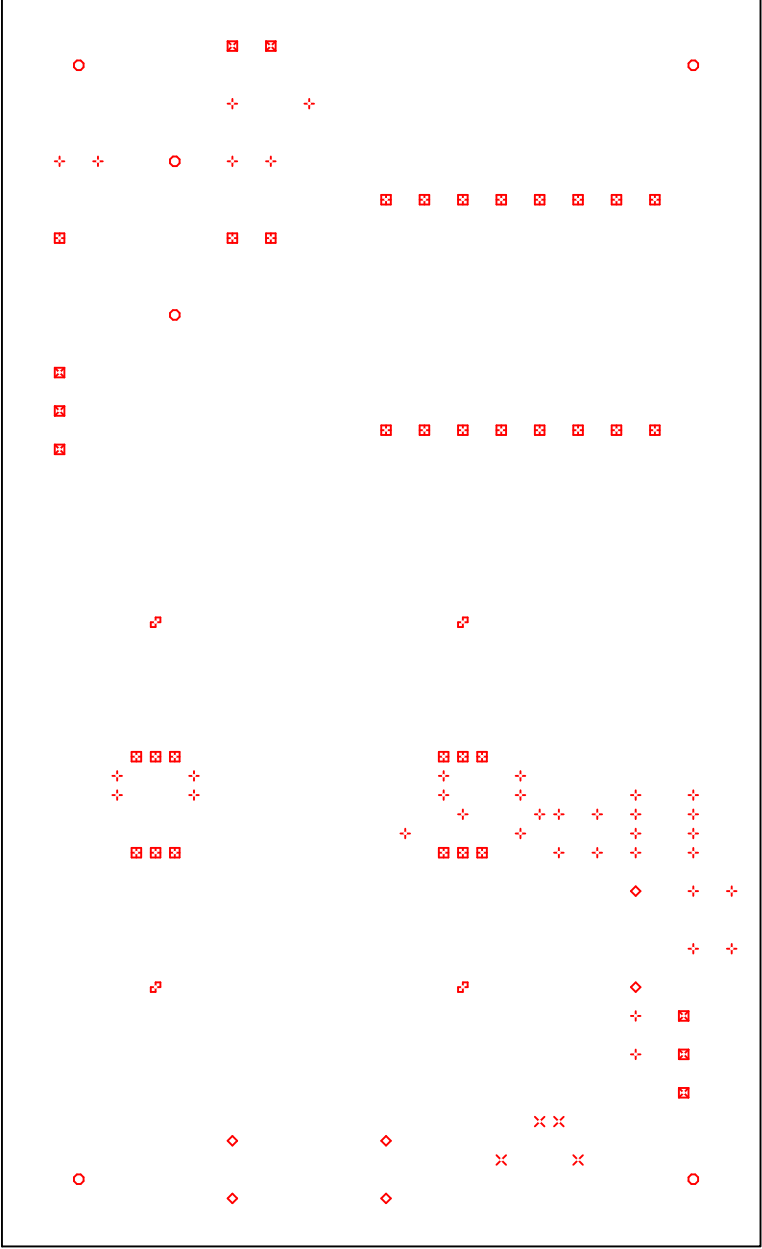

DRILL CHART				
SYM	DIAM	TOL	QTY	NOTE
x	0.508 mm		4	
+	0.787 mm		36	
◇	0.991 mm		6	
⊠	1.000 mm		8	
⊞	1.194 mm		31	
○	1.499 mm		2	
⊚	3.200 mm		4	
◊	4.191 mm		4	
TOTAL			95	

ETD cores and accessories

ETD39

CORE SETS

Effective core parameters

SYMBOL	PARAMETER	VALUE	UNIT
$\Sigma(l/A)$	core factor (C1)	0.737	mm ⁻¹
V_e	effective volume	11500	mm ³
l_e	effective length	92.2	mm
A_e	effective area	125	mm ²
A_{min}	minimum area	123	mm ²
m	mass of core half	≈30	g

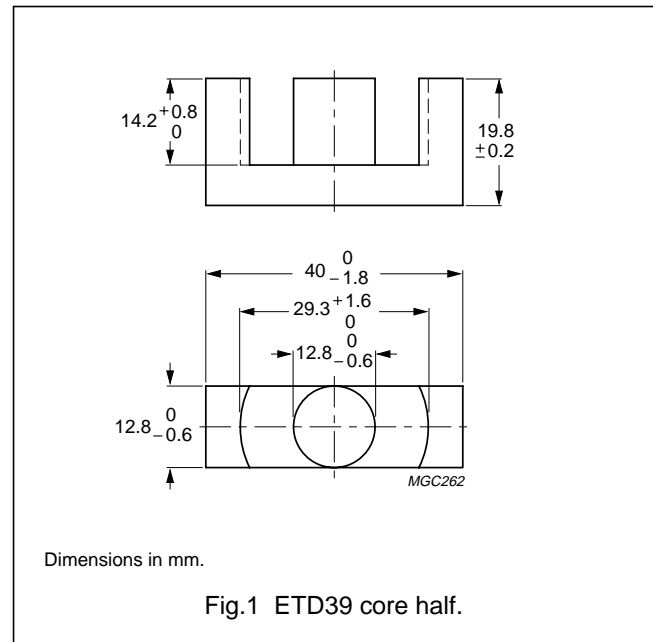

Core halves

Clamping force for A_L measurements, 40 ±20 N. Gapped cores are available on request.

GRADE	A_L (nH)	μ_e	AIR GAP (μm)	TYPE NUMBER
3C90	3000 ±25%	≈1900	≈0	ETD39-3C90
3F3	2800 ±25%	≈1750	≈0	ETD39-3F3

Properties of core sets under power conditions

GRADE	B (mT) at	CORE LOSS (W) at		
	H = 250 A/m; f = 25 kHz; T = 100 °C	f = 25 kHz; \hat{B} = 200 mT; T = 100 °C	f = 100 kHz; \hat{B} = 100 mT; T = 100 °C	f = 400 kHz; \hat{B} = 50 mT; T = 100 °C
3C90	≥330	≤1.4	≤1.5	–
3F3	≥320	–	≤1.4	≤2.5

ETD cores and accessories

ETD39

COIL FORMER

General data 16-pins ETD39 coil former

PARAMETER	SPECIFICATION
Coil former material	polybutyleneterephthalate (PBT), glass-reinforced, flame retardant in accordance with "UL 94V-0"; UL file number E45329(R)
Pin material	copper-tin alloy (CuSn), tin-lead alloy (SnPb) plated
Maximum operating temperature	155 °C, "IEC 60085", class F
Resistance to soldering heat	"IEC 60068-2-20", Part 2, Test Tb, method 1B, 350 °C, 3.5 s
Solderability	"IEC 60068-2-20", Part 2, Test Ta, method 1

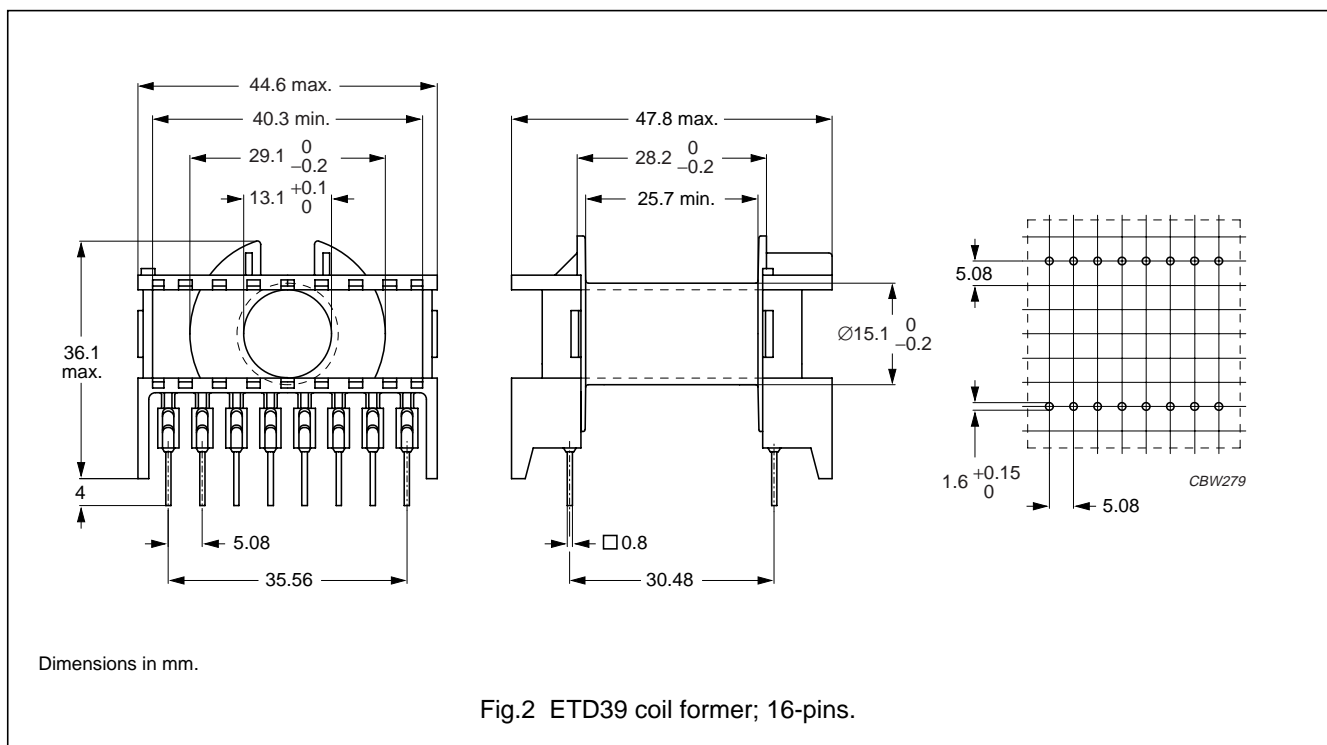

Winding data for 16-pins ETD39 coil former

NUMBER OF SECTIONS	WINDING AREA (mm ²)	MINIMUM WINDING WIDTH (mm)	AVERAGE LENGTH OF TURN (mm)	TYPE NUMBER
1	177	25.7	69	CPH-ETD39-1S-16P ⁽¹⁾

Note

- 1. Also available with Ø1.0 mm pins.