

NOTE



All numerical values are in metric units [with U.S. customary units in brackets]. Dimensions are in millimeters. Unless otherwise specified, dimensions have a tolerance of ± 0.13 and angles have a tolerance of $\pm 2^\circ$. Figures and illustrations are for identification only and are not drawn to scale.

1. INTRODUCTION

This specification covers the requirements for application of the AMPSEAL Automotive Plug Connector and Header Assembly System. The plug assembly will accept multiple socket contacts. All plug and header assemblies are color coded as a positive mating feature.

When corresponding with TE Connectivity (TE) Representatives, use the terminology provided in this specification to facilitate your inquiry for information. Basic terms and features of the plug connector and header assemblies are provided in Figure 1.

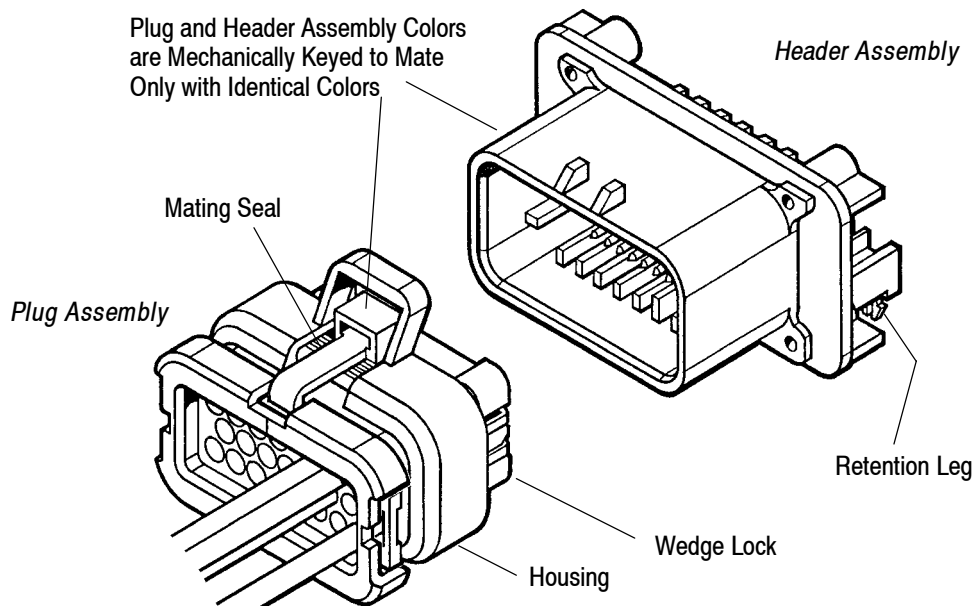

Figure 1

2. REFERENCE MATERIALS

2.1. Revision Summary

- Updated document to corporate requirements
- New logo

2.2. Customer Assistance

Reference Part Number 770520 and Product Code 2658 are representative numbers that identify the AMPSEAL Automotive Connector Product Line. These numbers are used in a customer service network to access tooling and product application information. This service is provided by your local TE Representative or, after purchase, by calling the Tooling Assistance Center number at the bottom of this page.

2.3. Drawings

Customer Drawings for specific products are available from the responsible TE Engineering Department via the service network. The information contained in the Customer Drawings takes priority if there is a conflict with this specification or with any other technical documentation supplied by TE.

2.4. Specifications

This product meets or exceeds the requirements outlined in specification ISO/CD 8092/2.

2.5. Instructional Material

The following Instruction Sheets (408-series) are supporting documents available to assist with product application, and tool setup and operation.

408-3229	Automotive Plug Connector Assembly 770680
408-9592	Hand Crimping Tool 58440-1
408-9999	PRO-CRIMPER* III Hand Tool Assembly 58529-1 with Die Assembly 58529-2
408-8040	Heavy Duty Miniature Quick-Change Applicators with Mechanical Feed System

3. PLUG REQUIREMENTS

3.1. Wire

A. Wire Selection

The contact will accept wire ranging in size from 20 to 16 AWG and 1.5 mm². Wire insulation diameter shall be a minimum dimension of 1.7 mm and a maximum dimension of 2.7 mm.

B. Wire Preparation

Wire strip length shall be 5.1 ± 0.4 mm. Reasonable care shall be taken during the stripping operation to ensure the conductor is not nicked, scraped, or cut.

3.2. Crimped Contact

A. Contact Crimping

The contacts shall be crimped in accordance with the material packaged with the tooling; refer to the charts in Figure 2.



Contacts are available in loose piece form for hand tool crimping. Do NOT cut strip form (reeled) contacts into loose piece form. This will produce burrs on the cutoff tab which will damage the wire seal in the plug assembly.

B. Inspection

Inspect crimped contacts for conditions shown in Figure 2.

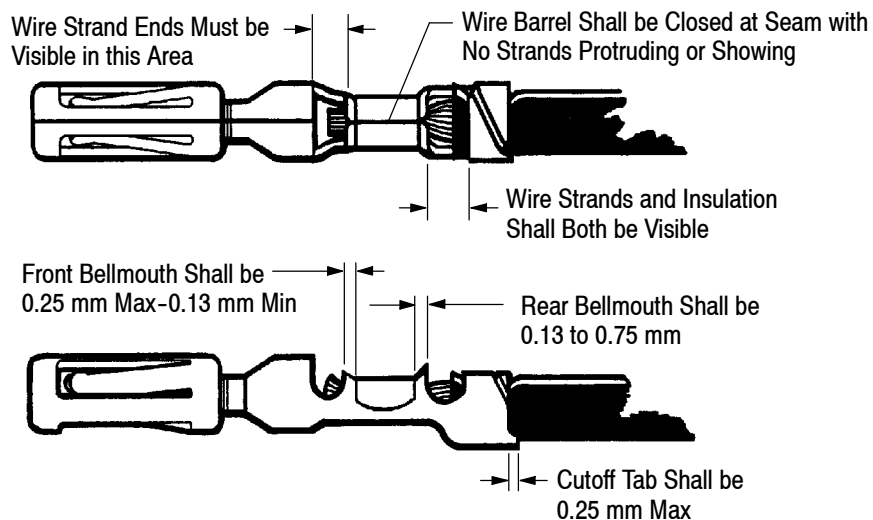

Figure 2 (cont'd)

WIRE		WIRE BARREL		INSULATION BARREL			
SIZE		INSULATION DIA RANGE	STRIP LENGTH ± 0.4	CRIMP HEIGHT	CRIMP WIDTH (NOMINAL)	CRIMP HEIGHT MAX.	CRIMP WIDTH ± 0.1
mm ²	[AWG]						
0.5	20	1.7-2.7	5.1	1.17 ± 0.08	2.03	3.2	3.1
0.8	18			1.27 ± 0.05			
1.4	16			1.40 ± 0.05			
1.5	---	2.2-2.4	5.1	1.40 ± 0.05			

Figure 2 (end)



Wire stripping tool jaws may leave corrugated indentations on the surface of the wire insulation. This is especially severe with cross-linked polyethylene (high temperature) insulation. If these indentations occur at the location of the wire seal, leakage may result. Insulation surface within 26 mm from the tip of the contact must be smooth and free of residual indentations.



It is important in any application that the far end of the cable be sealed or otherwise isolated from the environment, and that the insulation is not cut or damaged.

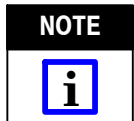

Care shall be taken to ensure that the wire insulation is not cut or broken during the crimping operation, and to ensure that the insulation is not crimped into the wire barrel.

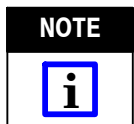

The ends of the insulation barrel shall be wrapped around the wire insulation, leaving no sharp points to damage the rubber wire seal.

C. Alignment

The axial concentricity of the crimped contact shall fall into an area defined by a 2 mm diameter cylinder whose center is the centerline of the contact front end. See Figure 3.

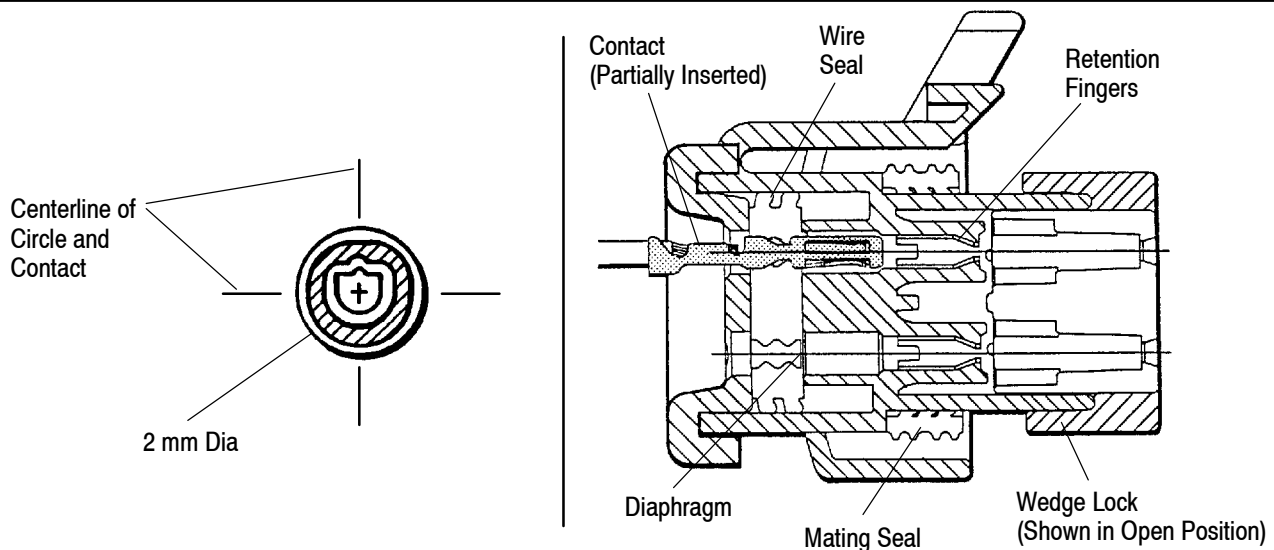

Figure 3

3.3. Assembly Procedures

Check to be sure the wedge lock is in the **open**, or as-shipped, position (see Figure 3). Then, proceed as follows:

1. To insert a contact, push it straight into the appropriate circuit cavity as far as it will go (see Figure 4).
2. Pull back on the contact wire with a force of 1 or 2 lbs to be sure the retention fingers are holding the contact (see Figure 4).

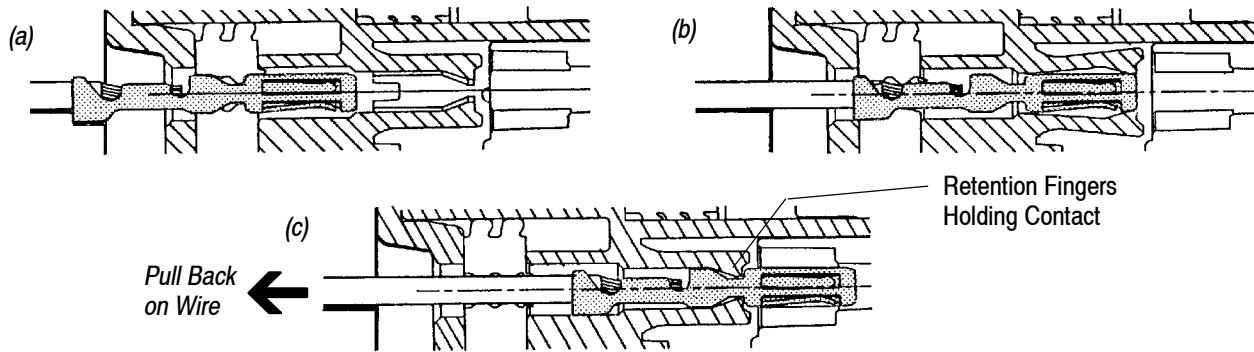

Figure 4

3. After all required contacts have been inserted, the wedge lock must be closed to its **locked** position. Release the locking latches by squeezing them inward (see Figure 5).

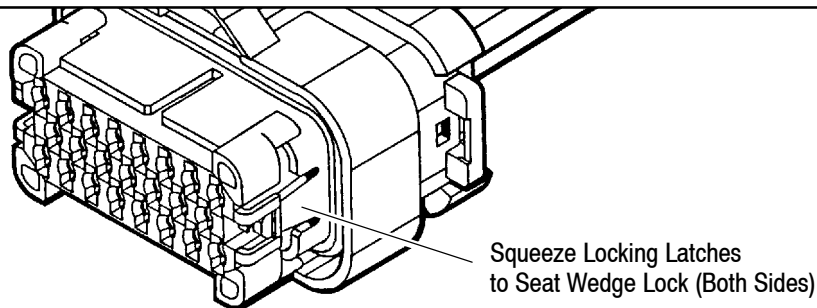

Figure 5

4. Slide the wedge lock into the housing until it is flush with the housing (see Figure 6).

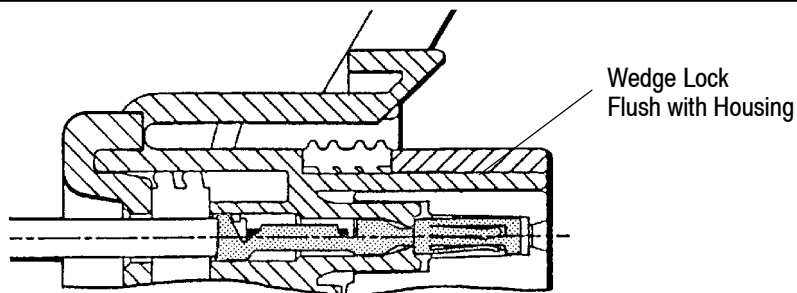

Figure 6

3.4. Disassembly Procedures (Contact Removal)

Refer to Figure 7 and proceed as follows:

1. Insert a 4.8-mm wide screwdriver blade between the mating seal and one of the red wedge lock tabs.
2. Pry open the wedge lock to the open (as shipped) position.
3. While rotating the wire back and forth over a half turn (1/4 turn in each direction), gently pull the wire until the contact is removed.

NOTE

The wedge lock should never be removed from the housing for insertion or removal of the contacts.



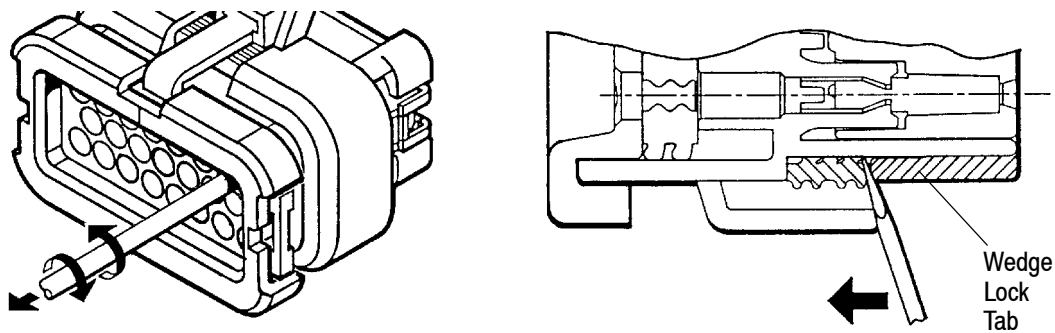

Figure 7

3.5. Seal Plug

All circuits are sealed by a diaphragm in the rubber wire seal. During plug connector assembly, the diaphragm is pierced as the contact passes through it. Unused circuit cavities, unless accidentally perforated, will remain sealed. Seal Plug 770678-1 is designed to keep out contaminants if diaphragm is pierced. Insert seal plug, **large end first**, into the circuit cavity as far as it will go. An insertion tool is not required for this procedure. See Figure 8.

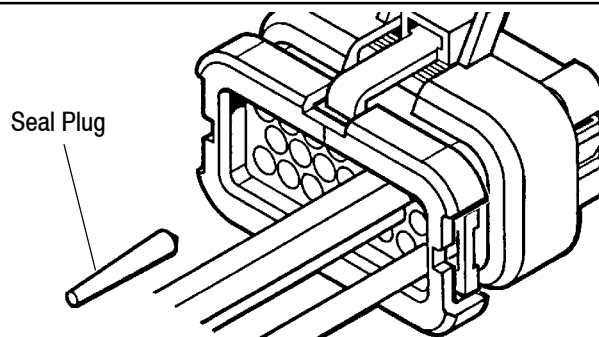

Figure 8

3.6. Wedge Lock

The wedge lock has slotted openings in the forward, or mating end. These slots accommodate circuit test tabs that are approximately 3.3 X 0.6 mm, which prevent damage to the receptacle. For circuit testing in the field, use a flat probe such as a pocket knife blade. Do **NOT** use a sharp point such as an ice pick.

3.7. Application Information

Please refer to the plug assembly customer drawing for the size opening that will clear the completed plug assembly (e.g., the 23 position plug assembly will pass through a 50 mm diameter opening). See Figure 9.

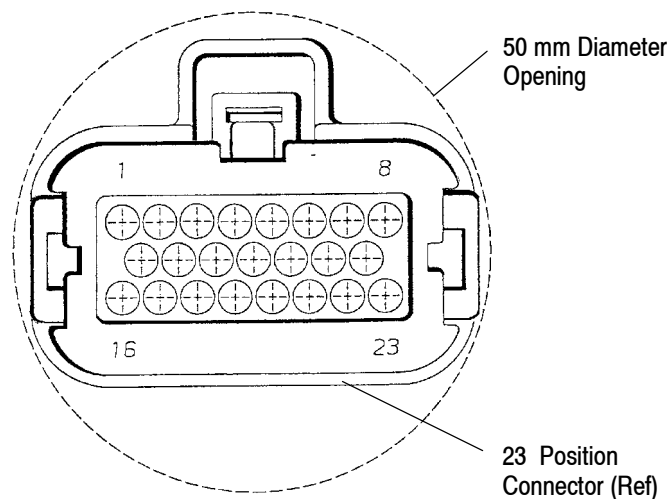

Figure 9

3.8. Service - Voltage Reading

CAUTION Do NOT pierce wire insulation to take voltage readings.

It has been common practice in electrical troubleshooting to probe wires by piercing the insulation with a sharp point. This practice should be discouraged when dealing with the AMPSEAL plug assembly, or any other sealed connector system. The resulting pinholes in the insulation will allow moisture to invade the system by traveling along the wire strands. This nullifies the effectiveness of the connector seals and could result in system failure.

3.9. Header Assembly Requirements

A. Printed Circuit (PC) Board

The pc board layout requirements shall be as shown in Figure 10 for the 23-position right-angle connector. For connector sizes other than the one shown, it will be necessary to refer to the Customer Drawings. Customer Drawings can be obtained by contacting TE Engineering at the Tooling Assistance Center or Product Information Number at the bottom of page 1. The pc board thickness shall be 1.57 mm.

The header assembly is designed to be compatible with any standard wave soldering process which uses tin-lead solder. However, there must be NO interruptions of the conveyor carrying the printed circuit boards through the solder bath.

CAUTION Care MUST be taken not to leave the AMPSEAL headers exposed directly to the solder flow during an interruption. Any headers exposed to the solder flow longer than the normal soldering cycle must be rejected and replaced.

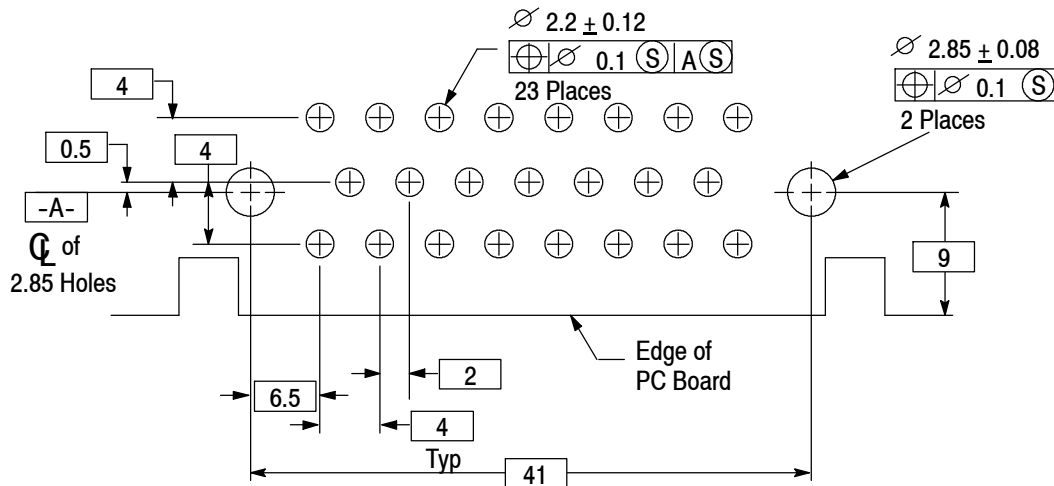

Figure 10

B. Panel Mounting (Cutout) Requirements

Panel mounting cutout requirements shall be as shown in Figure 11 for the 23-position connector. For connector sizes other than the one shown, it will be necessary to refer to the customer drawings. Customer Drawings can be obtained by contacting Tooling Assistance Center or Product Information Number at the bottom of page 1.

The maximum panel thickness shall be 2 mm for proper assembly clearance. Call Product Engineering for advice on thicker panels.

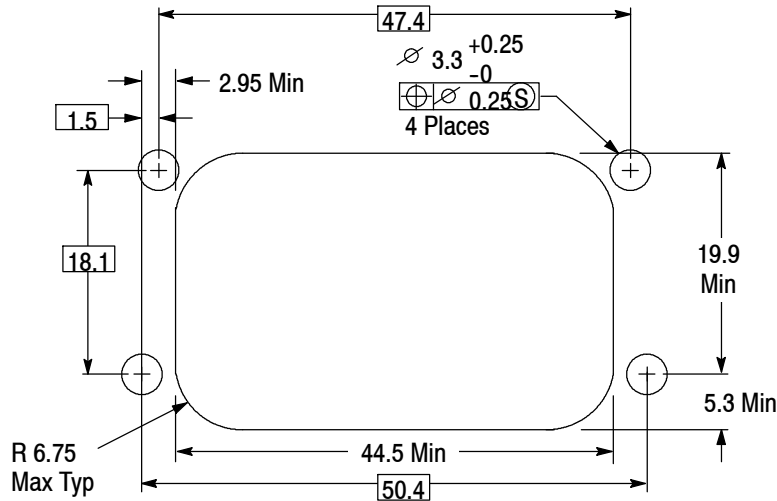

Figure 11

The header assembly is designed to be fastened to the enclosure by four No. 4 self-tapping screws. The screw length will depend upon panel thickness. See the customer drawing for necessary dimensions.

Header assemblies will be provided both with and without a formed-in-place gasket bonded to the flange. For sealing a bare flange to an enclosure, a loose piece gasket will be required. Each size header has its own specific gasket design. For assistance in choosing the proper gasket, contact the TE Engineering department for recommended gasket profiles. Whether for loose piece or bonded-in-place gaskets, the panel surface must be flat within 0.5 mm and have a surface roughness not in excess of 0.4 micrometer.

4. QUALIFICATIONS

4.1. Underwriters Laboratories Inc. (UL)

AMPSEAL Automotive Plug Connectors are Listed in Underwriters Laboratories Inc. (UL) File Number E28476.

4.2. Canadian Standards (CSA)

AMPSEAL Automotive Plug Connectors are Certified in CSA International File number LR7189.

5. TOOLING (Figure 12)

Loose piece contacts are designed to be crimped with a TE hand tool. Strip form contacts are designed to be crimped with a miniature applicator used in a semi-automatic or automatic machine. Tooling, applicators, and instruction material are listed in Figure 2.

For contact removal, a No.1 jeweler's screwdriver may be used. Refer to Instruction Sheet 408-3229 for contact extraction.

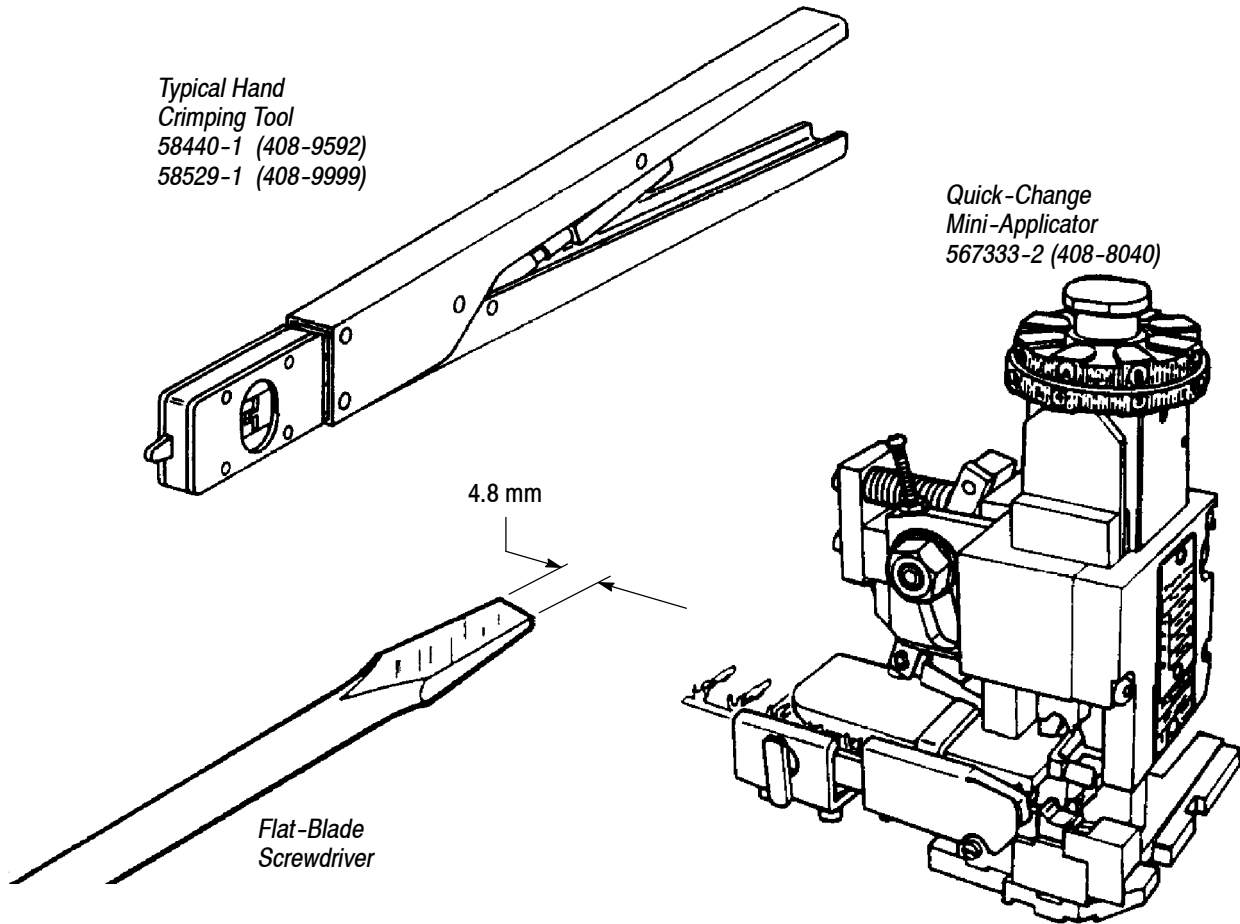

Figure 12

6. VISUAL AID

The following illustrations are to be used by production personnel to ensure properly applied product. The views suggest requirements for good applications. Applications considered visually incorrect should be inspected using the information in the main body of this document.

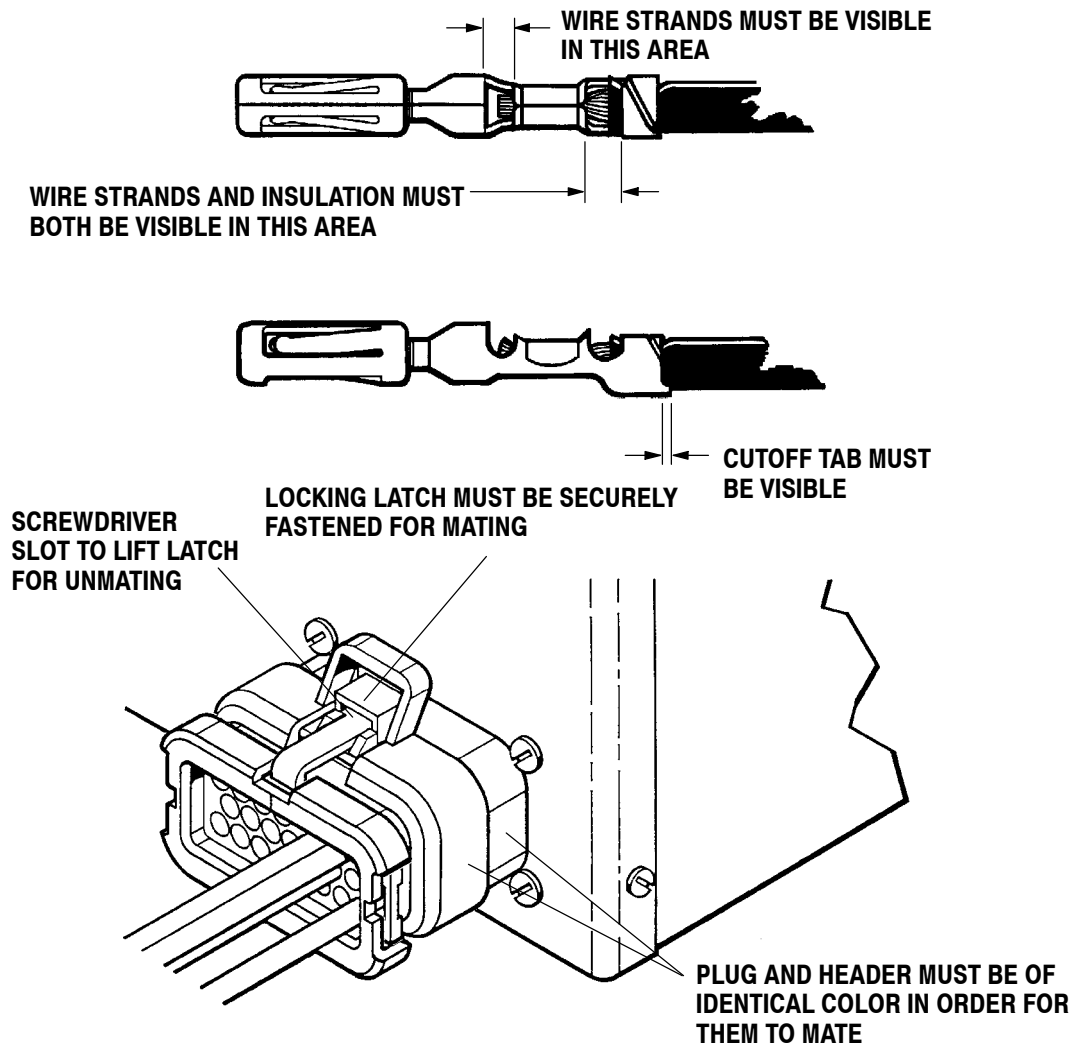

FIGURE 13. VISUAL AID