

1.6 Désignation des composants de la PUISSANCE

Projet : IUT6

Info : [DATA339]

Révision : 1, du 3 octobre 2007

Tableau 1.3. Liste de composants (projets-iut6.xls / DRIVER).

N°	Quantité	Référence	Désignation	PCB Footprint
1	1	B1	CATHODE	EMBASE
2	1	B2	ANODE	EMBASE
3	1	B3	DRAIN	EMBASE
4	1	B4	SOURCE	EMBASE
5	1	B5	+15V	EMBASE
6	1	B6	GND	EMBASE

1.7 Composants annexes



Figure 1.4. ablège du module de puissance APTM20AM06SG (DATA239-31 et 32.jpf).

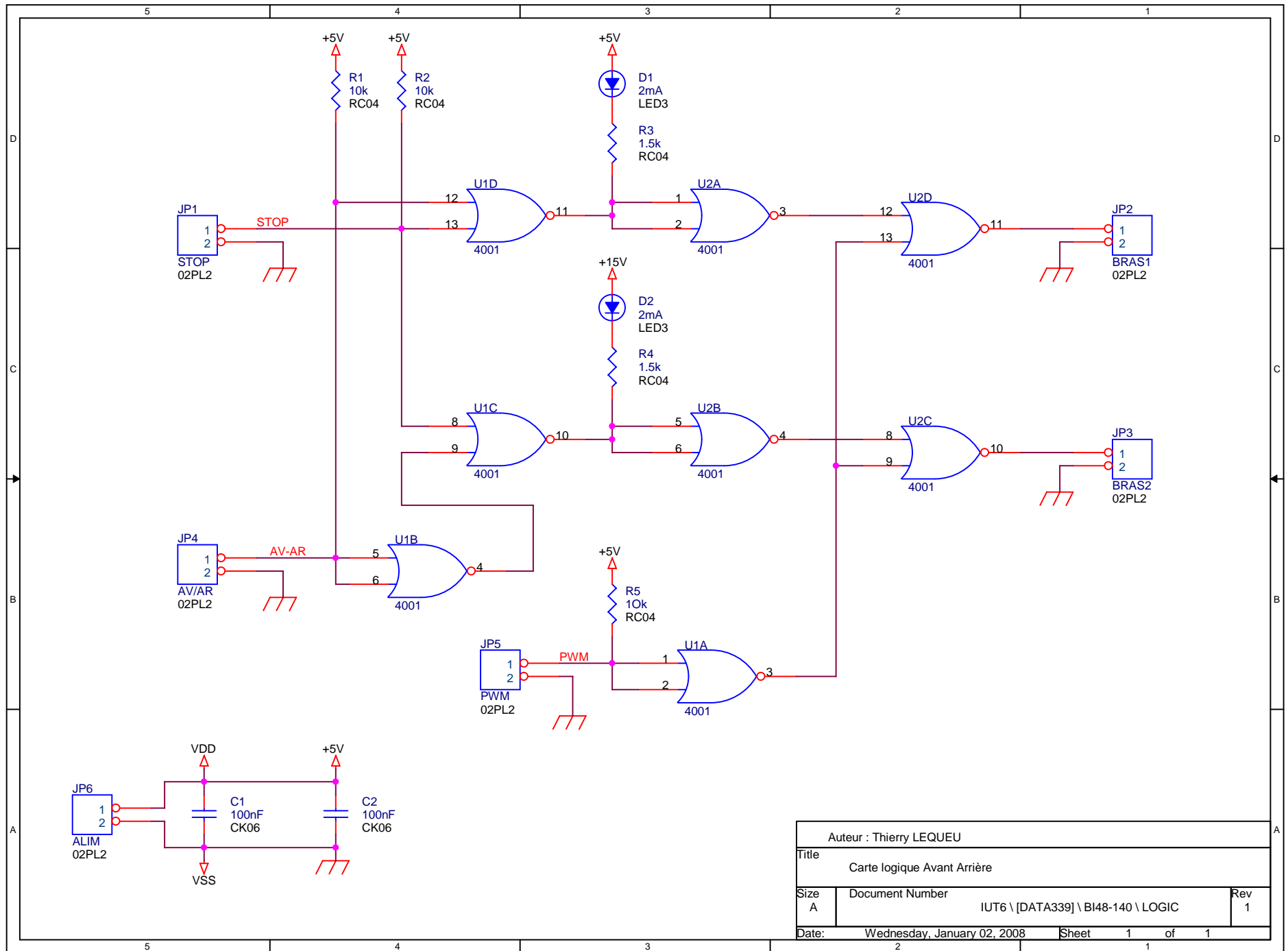

Auteur : Thierry LEQUEU		
Title Carte logique Avant Arrière		
Size A	Document Number IUT6 \ [DATA339] \ BI48-140 \ LOGIC	Rev 1
Date: Wednesday, January 02, 2008	Sheet 1	of 1

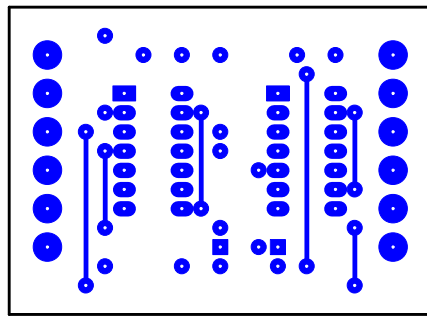

Face TOP

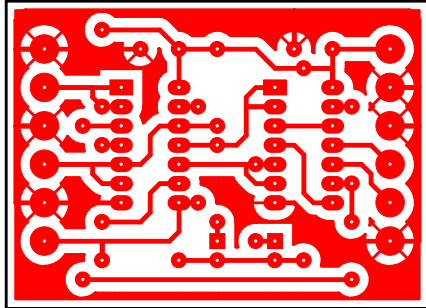

Face BOT
Thierry LEQUEU

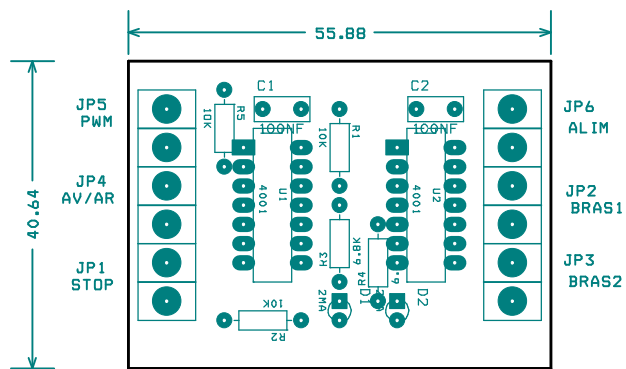

FACE AST

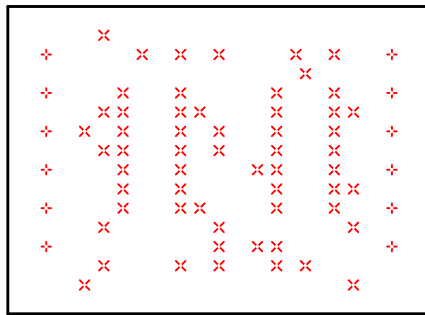

FACE DRD

DRILL CHART				
SYM	DIAM	TOL	QTY	NOTE
x	0.787 mm		58	
+	1.000 mm		12	
TOTAL			70	