

10.2 CON-SPI / Connecteur pour interface SPI

10.2.1 Définition

Projet : IUT6

Info : [DIV616]

Révision : 1 du 7 septembre 2011

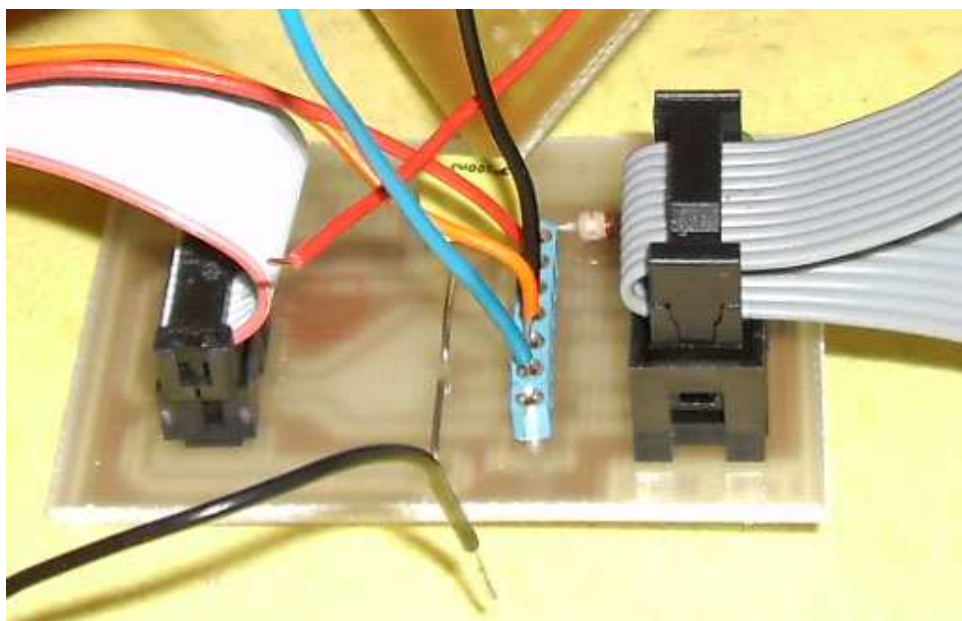

Figure 10.3. Vue de carte électronique (images-maquettes\CON-SPI-11.jpg).

10.2.2 Liste des documents

- Schéma électronique.
- Circuit imprimé coté cuivre.
- Circuit imprimé coté composants.
- Implantation des composants.
- Documentations des composants.

10.2.3 Désignation des composants

Tableau 10.2. Liste de composants (projets-iut6.xls / XXX).

N°	Quantité	Référence	Désignation	Empreinte
1	1	C1	100nF	CK06
2	1	D1	2mA verte	LED03
3	1	JP1	TEST	07PL1
4	1	JP2	QuickEval SPI	14SH079L
5	1	JP3	CON ISP	10SH100L
6	1	R1	1.5k	RC04L

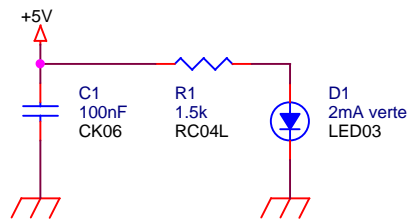
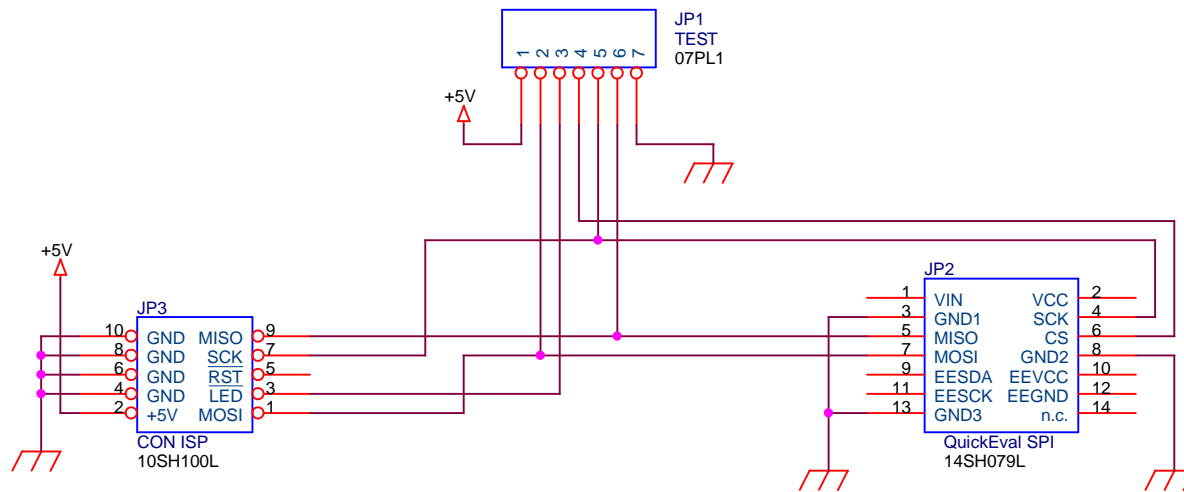

Auteur : Thierry LEQUEU		
Title Connecteur pour bus SPI		
Size A	Document Number LMP4 \ [DIV614] \ AT90CAN \ CON-SPI	Rev 1
Date:	Wednesday, September 07, 2011	Sheet 1 of 1

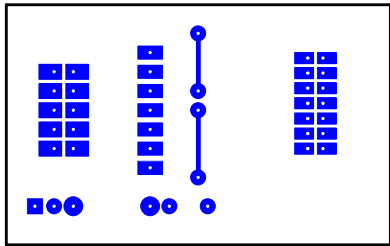

Face TOP

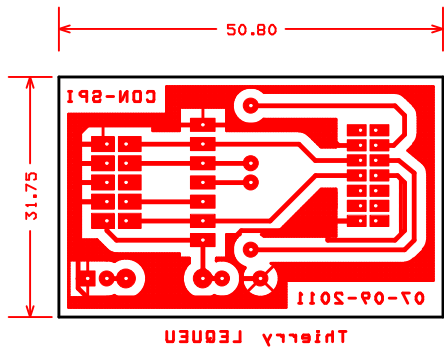

Face BOT

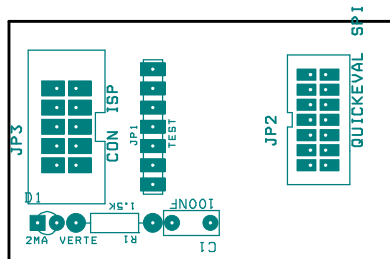

FACE AST

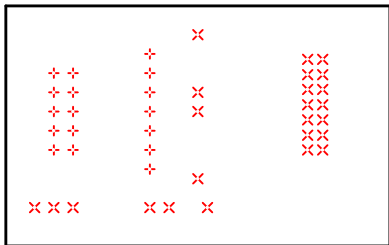

FACE DRD

DRILL CHART				
SYM	DIAM	TOL	QTY	NOTE
x	0.787 mm		24	
+	0.991 mm		17	
TOTAL			41	