

16-CHANNEL ANALOG MULTIPLEXER/DEMULTIPLEXER

FEATURES

- Low "ON" resistance:  
80 Ω (typ.) at VCC = 4.5 V  
70 Ω (typ.) at VCC = 6.0 V  
60 Ω (typ.) at VCC = 9.0 V  
typical "break before make" built-in
- Output capability: non-standard
- ICC category: MSI

GENERAL DESCRIPTION

The 74HC/HCT4067 are high-speed Si-gate CMOS devices and are pin compatible with the "4067" of the "4000B" series. They are specified in compliance with JEDEC standard no. 7A.

The 74HC/HCT4067 are 16-channel analog multiplexers/demultiplexers with four address inputs (S0 to S3), an active LOW enable input (E), sixteen independent inputs/outputs (Y0 to Y15) and a common input/output (Z).

The "4067" contains sixteen bidirectional analog switches, each with one side connected to an independent input/output (Y0 to Y15) and the other side connected to a common input/output (Z).

With E LOW, one of the sixteen switches is selected (low impedance ON-state) by S0 to S3. All unselected switches are in the high impedance OFF-state. With E HIGH, all switches are in the high impedance OFF-state, independent of S0 to S3.

The analog inputs/outputs (Y0 to Y15, and Z) can swing between VCC as a positive limit and GND as a negative limit. VCC to GND may not exceed 10 V.

SYMBOL	PARAMETER	CONDITIONS	TYPICAL		UNIT
			HC	HCT	
tPZL/ tPZH	turn-on time E to V <sub>OS</sub> S <sub>n</sub> to V <sub>OS</sub>	C <sub>L</sub> = 15 pF R <sub>L</sub> = 1 kΩ V <sub>CC</sub> = 5 V	26	32	ns
			29	33	ns
tPLZ/ tPHZ	turn-off time E to V <sub>OS</sub> S <sub>n</sub> to V <sub>OS</sub>		27	26	ns
			29	30	ns
C <sub>I</sub>	input capacitance		3.5	3.5	pF
CPD	power dissipation capacitance per switch	notes 1 and 2	29	29	pF
C <sub>S</sub>	max. switch capacitance independent (Y) common (Z)		5	5	pF
			45	45	pF

GND = 0 V; T<sub>amb</sub> = 25 °C; t<sub>r</sub> = t<sub>f</sub> = 6 ns

Notes

1. CPD is used to determine the dynamic power dissipation (PD in μW):

$$P_D = CPD \times V_{CC}^2 \times f_i + \sum \{ (C_L + C_S) \times V_{CC}^2 \times f_o \}$$

where:  
 f<sub>i</sub> = input frequency in MHz  
 f<sub>o</sub> = output frequency in MHz  
 Σ { (C<sub>L</sub> + C<sub>S</sub>) × V<sub>CC</sub><sup>2</sup> × f<sub>o</sub> } = sum of outputs  
 C<sub>L</sub> = output load capacitance in pF  
 C<sub>S</sub> = max. switch capacitance in pF  
 V<sub>CC</sub> = supply voltage in V

2. For HC the condition is V<sub>I</sub> = GND to V<sub>CC</sub>  
 For HCT the condition is V<sub>I</sub> = GND to V<sub>CC</sub> - 1.5 V

PACKAGE OUTLINES

24-lead DIL; plastic (SOT101A).  
 24-lead mini-pack; plastic (SO24; SOT137A).

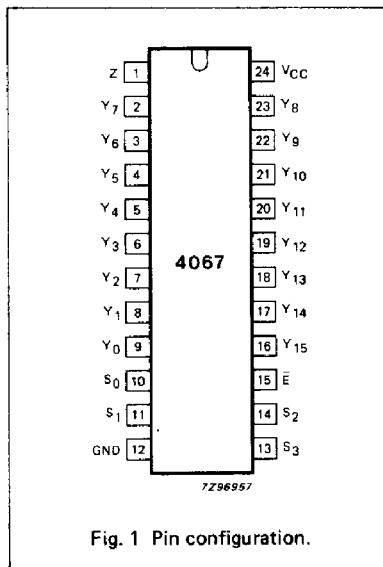

Fig. 1 Pin configuration.

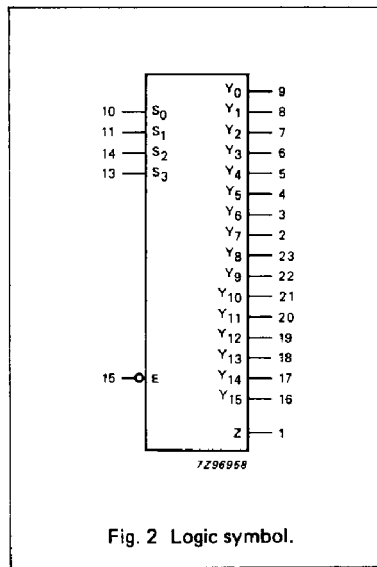

Fig. 2 Logic symbol.

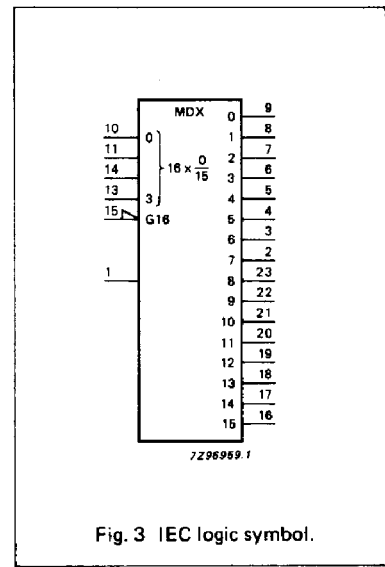

Fig. 3 IEC logic symbol.

**PIN DESCRIPTION**

PIN NO.	SYMBOL	NAME AND FUNCTION
1	Z	common input/output
9, 8, 7, 6, 5, 4, 3, 2, 23, 22, 21, 20, 19, 18, 17, 16	Y <sub>0</sub> to Y <sub>15</sub>	independent inputs/outputs
10, 11, 14, 13	S <sub>0</sub> to S <sub>3</sub>	address inputs
12	GND	ground (0 V)
15	E	enable input (active LOW)
24	V <sub>CC</sub>	positive supply voltage

**APPLICATIONS**

- Analog multiplexing and demultiplexing
- Digital multiplexing and demultiplexing
- Signal gating

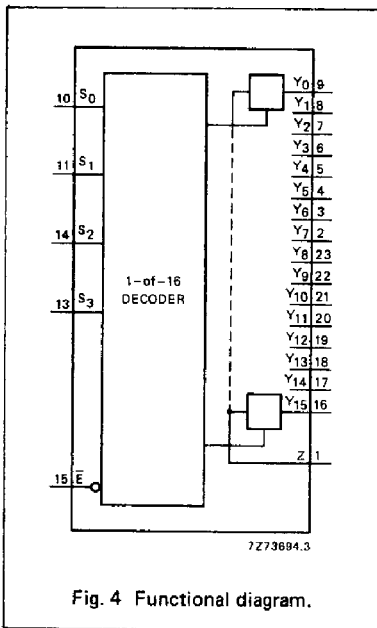

**FUNCTION TABLE**

E	INPUTS				CHANNEL ON
	S <sub>3</sub>	S <sub>2</sub>	S <sub>1</sub>	S <sub>0</sub>	
L	L	L	L	L	Y <sub>0</sub> - Z
L	L	L	L	H	Y <sub>1</sub> - Z
L	L	L	H	L	Y <sub>2</sub> - Z
L	L	L	H	H	Y <sub>3</sub> - Z
L	L	H	L	L	Y <sub>4</sub> - Z
L	L	H	L	H	Y <sub>5</sub> - Z
L	L	H	H	L	Y <sub>6</sub> - Z
L	L	H	H	H	Y <sub>7</sub> - Z
L	H	L	L	L	Y <sub>8</sub> - Z
L	H	L	L	H	Y <sub>9</sub> - Z
L	H	L	H	L	Y <sub>10</sub> - Z
L	H	L	H	H	Y <sub>11</sub> - Z
L	H	H	L	L	Y <sub>12</sub> - Z
L	H	H	L	H	Y <sub>13</sub> - Z
L	H	H	H	L	Y <sub>14</sub> - Z
L	H	H	H	H	Y <sub>15</sub> - Z
H	X	X	X	X	none

H = HIGH voltage level  
L = LOW voltage level  
X = don't care

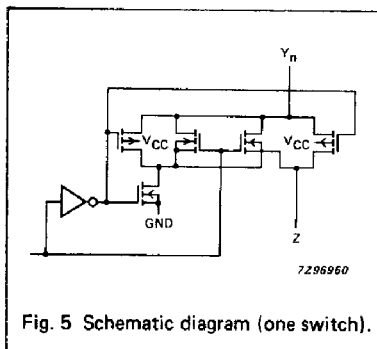

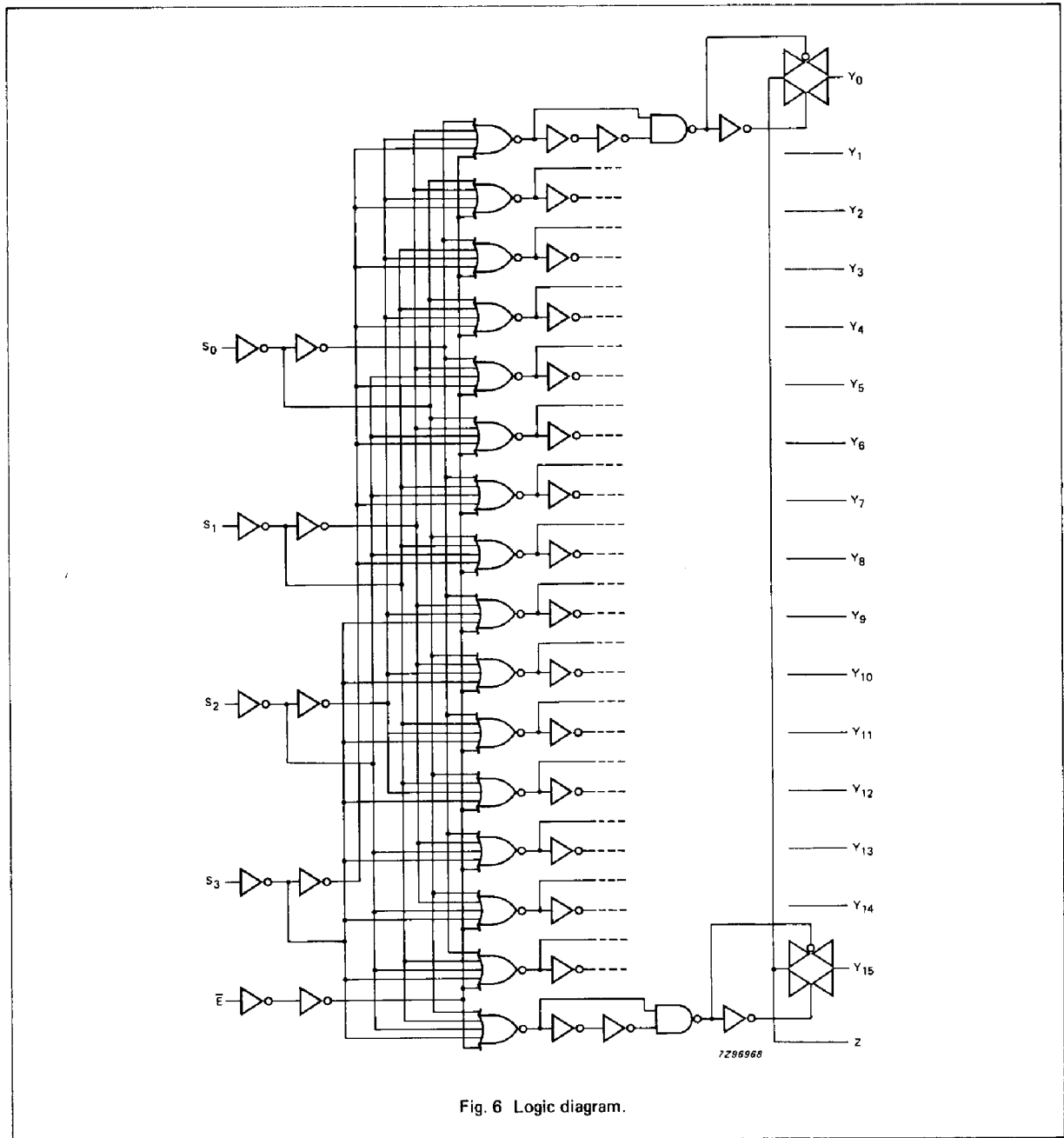

Fig. 6 Logic diagram.

**RATINGS**

Limiting values in accordance with the Absolute Maximum System (IEC 134)

Voltages are referenced to GND (ground = 0 V)

SYMBOL	PARAMETER	MIN.	MAX.	UNIT	CONDITIONS
V <sub>CC</sub>	DC supply voltage	-0.5	+11.0	V	
±I <sub>IK</sub>	DC digital input diode current		20	mA	for V <sub>I</sub> < -0.5 V or V <sub>I</sub> > V <sub>CC</sub> + 0.5 V
±I <sub>SK</sub>	DC switch diode current		20	mA	for V <sub>S</sub> < -0.5 V or V <sub>S</sub> > V <sub>CC</sub> + 0.5 V
±I <sub>S</sub>	DC switch current		25	mA	for -0.5 V < V <sub>S</sub> < V <sub>CC</sub> + 0.5 V
±I <sub>CC</sub> ; ±I <sub>GND</sub>	DC V <sub>CC</sub> or GND current		50	mA	
T <sub>stg</sub>	storage temperature range	-65	+150	°C	
P <sub>tot</sub>	power dissipation per package				for temperature range: -40 to +125 °C 74HC/HCT
	plastic DIL		750	mW	above +70 °C: derate linearly with 12 mW/K
	plastic mini-pack (SO)		500	mW	above +70 °C: derate linearly with 8 mW/K
P <sub>S</sub>	power dissipation per switch		100	mW	

**Note to ratings**

To avoid drawing V<sub>CC</sub> current out of terminal Z, when switch current flows in terminals Y<sub>n</sub>, the voltage drop across the bidirectional switch must not exceed 0.4 V. If the switch current flows into terminal Z, no V<sub>CC</sub> current will flow out of terminals Y<sub>n</sub>. In this case there is no limit for the voltage drop across the switch, but the voltages at Y<sub>n</sub> and Z may not exceed V<sub>CC</sub> or GND.

**RECOMMENDED OPERATING CONDITIONS**

SYMBOL	PARAMETER	74HC			74HCT			UNIT	CONDITIONS
		min.	typ.	max.	min.	typ.	max.		
V <sub>CC</sub>	DC supply voltage	2.0	5.0	10.0	4.5	5.0	5.5	V	
V <sub>I</sub>	DC input voltage range	GND		V <sub>CC</sub>	GND		V <sub>CC</sub>	V	
V <sub>S</sub>	DC switch voltage range	GND		V <sub>CC</sub>	GND		V <sub>CC</sub>	V	
T <sub>amb</sub>	operating ambient temperature range	-40		+85	-40		+85	°C	see DC and AC CHARACTERISTICS
T <sub>amb</sub>	operating ambient temperature range	-40		+125	-40		+125	°C	
t <sub>r</sub> , t <sub>f</sub>	input rise and fall times		6.0	1000 500 400 250		6.0	500	ns	V <sub>CC</sub> = 2.0 V V <sub>CC</sub> = 4.5 V V <sub>CC</sub> = 6.0 V V <sub>CC</sub> = 10.0 V

**DC CHARACTERISTICS FOR 74HC/HCT**

For 74HC:  $V_{CC} - GND = 2.0, 4.5, 6.0$  and  $9.0$  V  
 For 74HCT:  $V_{CC} - GND = 4.5$  V

SYMBOL	PARAMETER	$T_{amb}$ (°C)						UNIT	TEST CONDITIONS				
		74HC/HCT							$V_{CC}$ V	$I_s$ $\mu A$	$V_{is}$	$V_I$	
		+25			-40 to +85		-40 to +125						
		min.	typ.	max.	min.	max.	min.						max.
$R_{ON}$	ON-resistance (peak)		110 95 75	180 160 130		225 200 165		270 240 195	$\Omega$ $\Omega$ $\Omega$ $\Omega$	2.0 4.5 6.0 9.0	100 1000 1000 1000	$V_{CC}$ to GND	$V_{IH}$ or $V_{IL}$
$R_{ON}$	ON-resistance (rail)		150 90 80 70	— 160 140 120		— 200 175 150		— 240 210 180	$\Omega$ $\Omega$ $\Omega$ $\Omega$	2.0 4.5 6.0 9.0	100 1000 1000 1000	GND or $V_{CC}$	$V_{IH}$ or $V_{IL}$
$\Delta R_{ON}$	maximum variation of ON-resistance between any two channels		— 9 8 6						$\Omega$ $\Omega$ $\Omega$ $\Omega$	2.0 4.5 6.0 9.0		$V_{CC}$ to GND	$V_{IH}$ or $V_{IL}$

**Notes to DC characteristics**

- At supply voltages ( $V_{CC} - GND$ ) approaching 2 V, the analog switch ON-resistance becomes extremely non-linear. Therefore it is recommended that these devices be used to transmit digital signals only, when using these supply voltages.
- For test circuit measuring  $R_{ON}$  see Fig. 7.

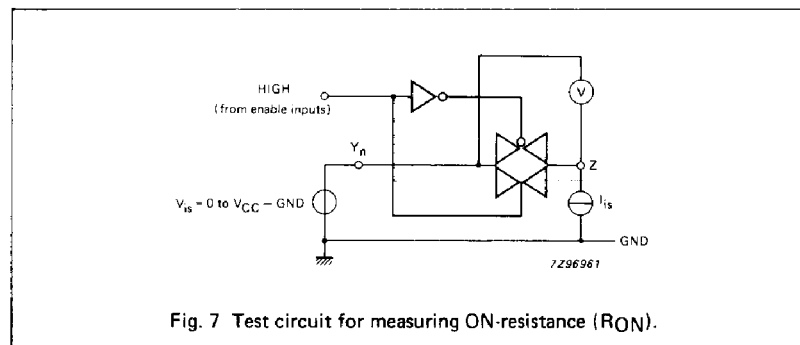

Fig. 7 Test circuit for measuring ON-resistance ( $R_{ON}$ ).

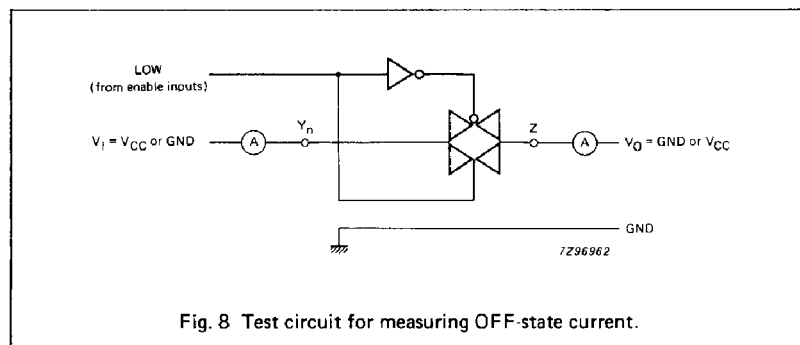
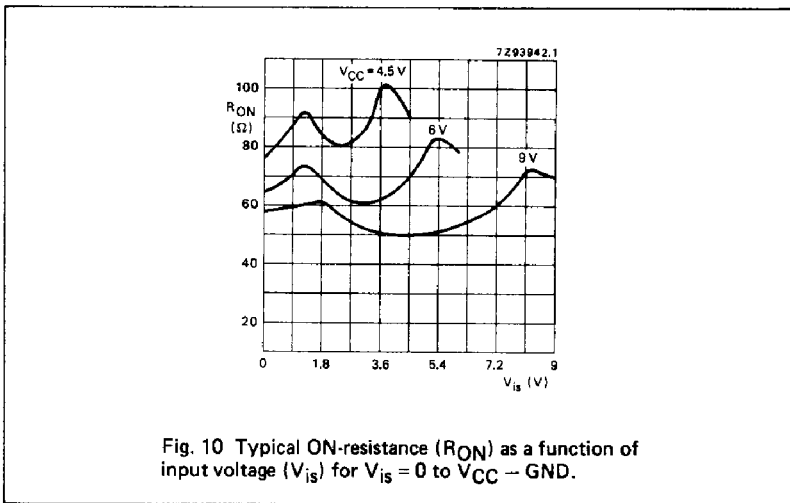
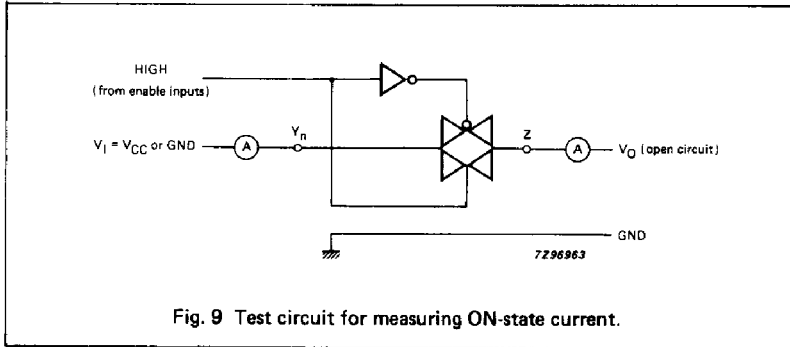

Fig. 8 Test circuit for measuring OFF-state current.



**DC CHARACTERISTICS FOR 74HC**

Voltages are referenced to GND (ground = 0 V)

SYMBOL	PARAMETER	T <sub>amb</sub> (°C)						UNIT	TEST CONDITIONS			
		74HC							V <sub>CC</sub> V	V <sub>I</sub>	OTHER	
		+25			-40 to +85		-40 to +125					
		min.	typ.	max.	min.	max.	min.					max.
V <sub>IH</sub>	HIGH level input voltage	1.5 3.15 4.2 6.3	1.2 2.4 3.2 4.7		1.5 3.15 4.2 6.3		1.5 3.15 4.2 6.3	V	2.0 4.5 6.0 9.0			
V <sub>IL</sub>	LOW level input voltage		0.8 2.1 2.8 4.3	0.50 1.35 1.80 2.70		0.50 1.35 1.80 2.70		0.50 1.35 1.80 2.70	V	2.0 4.5 6.0 9.0		
±I <sub>I</sub>	input leakage current			0.1 0.2		1.0 2.0		1.0 2.0	μA	6.0 10.0	V <sub>CC</sub> or GND	
±I <sub>S</sub>	analog switch OFF-state current per channel			0.1		1.0		1.0	μA	10.0	V <sub>IH</sub> or V <sub>IL</sub>	V <sub>S</sub>   = V <sub>CC</sub> - GND (see Fig. 8)
±I <sub>S</sub>	analog switch OFF-state current all channels			0.8		8.0		8.0	μA	10.0	V <sub>IH</sub> or V <sub>IL</sub>	V <sub>S</sub>   = V <sub>CC</sub> - GND (see Fig. 9)
±I <sub>S</sub>	analog switch ON-state current			0.8		8.0		8.0	μA	10.0	V <sub>IH</sub> or V <sub>IL</sub>	V <sub>S</sub>   = V <sub>CC</sub> - GND (see Fig. 9)
I <sub>CC</sub>	quiescent supply current			8.0 16.0		80.0 160		160 320	μA	6.0 10.0	V <sub>CC</sub> or GND	V <sub>is</sub> = GND or V <sub>CC</sub> ; V <sub>os</sub> = V <sub>CC</sub> or GND

AC CHARACTERISTICS FOR 74HC

GND = 0 V;  $t_r = t_f = 6$  ns;  $C_L = 50$  pF

SYMBOL	PARAMETER	T <sub>amb</sub> (°C)						UNIT	TEST CONDITIONS		
		74HC							V <sub>CC</sub> V	OTHER	
		+25			-40 to +85		-40 to +125				
		min.	typ.	max.	min.	max.	min.				max.
t <sub>PHL</sub> / t <sub>PLH</sub>	propagation delay V <sub>is</sub> to V <sub>os</sub> ; Y <sub>n</sub> to Z		25	75		95		110	ns	2.0 4.5 6.0 9.0	R <sub>L</sub> = ∞; C <sub>L</sub> = 50 pF (see Fig. 16)
			9	15		19		22			
			7	13		16		19			
			5	9		11		14			
t <sub>PHL</sub> / t <sub>PLH</sub>	propagation delay V <sub>is</sub> to V <sub>os</sub> ; Z to Y <sub>n</sub>		18	60		75		90	ns	2.0 4.5 6.0 9.0	
			6	12		15		18			
			5	10		13		15			
			4	8		10		12			
t <sub>PHZ</sub> / t <sub>PLZ</sub>	turn-off time E to Y <sub>n</sub>		74	250		315		375	ns	2.0 4.5 6.0 9.0	
			27	50		63		75			
			22	43		54		64			
			20	38		48		57			
t <sub>PHZ</sub> / t <sub>PLZ</sub>	turn-off time S <sub>n</sub> to Y <sub>n</sub>		83	250		315		375	ns	2.0 4.5 6.0 9.0	
			30	50		63		75			
			24	43		54		64			
			21	38		48		57			
t <sub>PHZ</sub> / t <sub>PLZ</sub>	turn-off time E to Z		85	275		345		415	ns	2.0 4.5 6.0 9.0	
			31	55		69		83			
			25	47		59		71			
			24	42		53		63			
t <sub>PHZ</sub> / t <sub>PLZ</sub>	turn-off time S <sub>n</sub> to Z		94	290		365		435	ns	2.0 4.5 6.0 9.0	
			34	58		73		87			
			27	47		62		74			
			25	45		56		68			
t <sub>PZH</sub> / t <sub>PZL</sub>	turn-on time E to Y <sub>n</sub>		80	275		345		415	ns	2.0 4.5 6.0 9.0	
			29	55		69		83			
			23	47		59		71			
			17	42		53		63			
t <sub>PZH</sub> / t <sub>PZL</sub>	turn-on time S <sub>n</sub> to Y <sub>n</sub>		88	300		375		450	ns	2.0 4.5 6.0 9.0	
			32	60		75		90			
			26	51		64		77			
			18	45		56		68			
t <sub>PZH</sub> / t <sub>PZL</sub>	turn-on time E to Z		85	275		345		415	ns	2.0 4.5 6.0 9.0	
			31	55		69		83			
			25	47		59		71			
			18	42		53		63			
t <sub>PZH</sub> / t <sub>PZL</sub>	turn-on time S <sub>n</sub> to Z		94	300		375		450	ns	2.0 4.5 6.0 9.0	
			34	60		75		90			
			27	51		64		77			
			19	45		56		68			

Note to AC characteristics for 74HC

Due to higher Z terminal capacitance (16 switches versus 1) the delay figures to the Z terminal are higher than those to the Y terminal.



## DC CHARACTERISTICS FOR 74HCT

Voltages are referenced to GND (ground = 0 V)

SYMBOL	PARAMETER	T <sub>amb</sub> (°C)						UNIT	TEST CONDITIONS			
		74HCT							V <sub>CC</sub> V	V <sub>I</sub>	OTHER	
		+25			-40 to +85		-40 to +125					
		min.	typ.	max.	min.	max.	min.		max.			
V <sub>IH</sub>	HIGH level input voltage	2.0	1.6		2.0		2.0		V	4.5 to 5.5		
V <sub>IL</sub>	LOW level input voltage		1.2	0.8		0.8		0.8	V	4.5 to 5.5		
±I <sub>I</sub>	input leakage current			0.1		1.0		1.0	μA	5.5	V <sub>CC</sub> or GND	
±I <sub>S</sub>	analog switch OFF-state current per channel			0.1		1.0		1.0	μA	5.5	V <sub>IH</sub> or V <sub>IL</sub>	V <sub>S</sub>   = V <sub>CC</sub> - GND (see Fig. 8)
±I <sub>S</sub>	analog switch OFF-state current all channels			0.8		8.0		8.0	μA	5.5	V <sub>IH</sub> or V <sub>IL</sub>	V <sub>S</sub>   = V <sub>CC</sub> - GND (see Fig. 9)
±I <sub>S</sub>	analog switch ON-state current			0.8		8.0		8.0	μA	5.5	V <sub>IH</sub> or V <sub>IL</sub>	V <sub>S</sub>   = V <sub>CC</sub> - GND (see Fig. 9)
I <sub>CC</sub>	quiescent supply current			8.0		80.0		160	μA	4.5 to 5.5	V <sub>CC</sub> or GND	V <sub>is</sub> = GND or V <sub>CC</sub> ; V <sub>os</sub> = V <sub>CC</sub> or GND
ΔI <sub>CC</sub>	additional quiescent supply current per input pin for unit load coefficient is 1 (note 1)		100	360		450		490	μA	4.5 to 5.5	V <sub>CC</sub> -2.1 V	other inputs at V <sub>CC</sub> or GND

## Note

1. The value of additional quiescent supply current (ΔI<sub>CC</sub>) for a unit load of 1 is given here. To determine ΔI<sub>CC</sub> per input, multiply this value by the unit load coefficient shown in the table below.

INPUT	UNIT LOAD COEFFICIENT
E	0.6
S <sub>n</sub>	0.5

**AC CHARACTERISTICS FOR 74HCT**

GND = 0 V;  $t_r = t_f = 6$  ns

SYMBOL	PARAMETER	T <sub>amb</sub> (°C)						UNIT	TEST CONDITIONS		
		74HCT							V <sub>CC</sub> V	OTHER	
		+25			-40 to +85		-40 to +125				
		min.	typ.	max.	min.	max.	min.				max.
t <sub>PHL</sub> / t <sub>PLH</sub>	propagation delay V <sub>is</sub> to V <sub>os</sub> ; Y <sub>n</sub> to Z		9	15		19		22	ns	4.5	R <sub>L</sub> = ∞; C <sub>L</sub> = 50 pF (see Fig. 16)
t <sub>PHL</sub> / t <sub>PLH</sub>	propagation delay V <sub>is</sub> to V <sub>os</sub> ; Z to Y <sub>n</sub>		6	12		15		18	ns	4.5	
t <sub>PHZ</sub> / t <sub>PLZ</sub>	turn-off time Ē to Y <sub>n</sub>		26	55		69		83	ns	4.5	R <sub>L</sub> = 1 kΩ; C <sub>L</sub> = 50 pF (see Fig. 17)
t <sub>PHZ</sub> / t <sub>PLZ</sub>	turn-off time S <sub>n</sub> to Y <sub>n</sub>		31	55		69		83	ns	4.5	
t <sub>PHZ</sub> / t <sub>PLZ</sub>	turn-off time Ē to Z		30	60		75		90	ns	4.5	
t <sub>PHZ</sub> / t <sub>PLZ</sub>	turn-off time S <sub>n</sub> to Z		35	60		75		90	ns	4.5	
t <sub>PZH</sub> / t <sub>PZL</sub>	turn-on time Ē to Y <sub>n</sub>		32	60		75		90	ns	4.5	
t <sub>PZH</sub> / t <sub>PZL</sub>	turn-on time S <sub>n</sub> to Y <sub>n</sub>		35	60		75		90	ns	4.5	
t <sub>PZH</sub> / t <sub>PZL</sub>	turn-on time Ē to Z		38	65		81		98	ns	4.5	
t <sub>PZH</sub> / t <sub>PZL</sub>	turn-on time S <sub>n</sub> to Z		38	65		81		98	ns	4.5	

**Note to the AC characteristics**

Due to higher Z terminal capacitance (16 switches versus 1) the delay figures to the Z terminal are higher than those to the Y terminal.

**ADDITIONAL AC CHARACTERISTICS FOR 74HC/HCT**

Recommended conditions and typical values

GND = 0 V;  $t_r = t_f = 6$  ns

SYMBOL	PARAMETER	TYP.	UNIT	VCC V	V <sub>is(p-p)</sub> V	CONDITIONS
	sine-wave distortion f = 1 kHz	0.04 0.02	% %	4.5 9.0	4.0 8.0	R <sub>L</sub> = 10 k $\Omega$ ; C <sub>L</sub> = 50 pF (see Fig. 14)
	sine-wave distortion f = 10 kHz	0.12 0.06	% %	4.5 9.0	4.0 8.0	R <sub>L</sub> = 10 k $\Omega$ ; C <sub>L</sub> = 50 pF (see Fig. 14)
	switch "OFF" signal feed-through	-50 -50	dB dB	4.5 9.0	note 1	R <sub>L</sub> = 600 $\Omega$ ; C <sub>L</sub> = 50 pF f = 1 MHz (see Figs 11 and 15)
f <sub>max</sub>	minimum frequency response (-3 dB)	90 100	MHz MHz	4.5 9.0	note 2	R <sub>L</sub> = 50 $\Omega$ ; C <sub>L</sub> = 10 pF (see Figs 12 and 13)
C <sub>S</sub>	maximum switch capacitance independent (Y) common (Z)	5 45	pF pF			

**Notes to the AC characteristics***General note*V<sub>is</sub> is the input voltage at Y<sub>n</sub> or Z terminal, whichever is assigned as an input.V<sub>os</sub> is the output voltage at Y<sub>n</sub> or Z terminal, whichever is assigned as an output.*Notes*

1. Adjust input voltage V<sub>is</sub> is 0 dBm level (0 dBm = 1 mW into 600  $\Omega$ ).
2. Adjust input voltage V<sub>is</sub> is 0 dBm level at V<sub>os</sub> for 1 MHz (0 dBm = 1 mW into 50  $\Omega$ ).

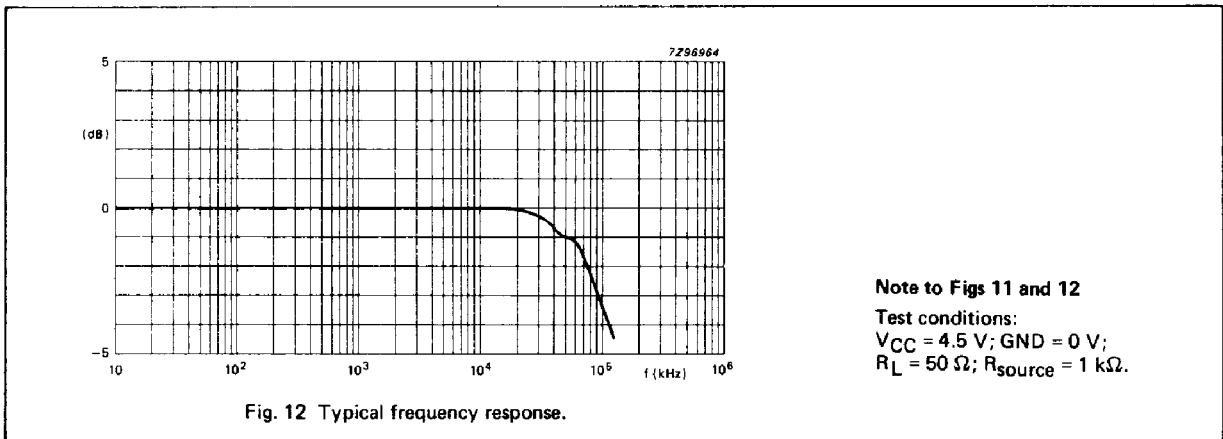
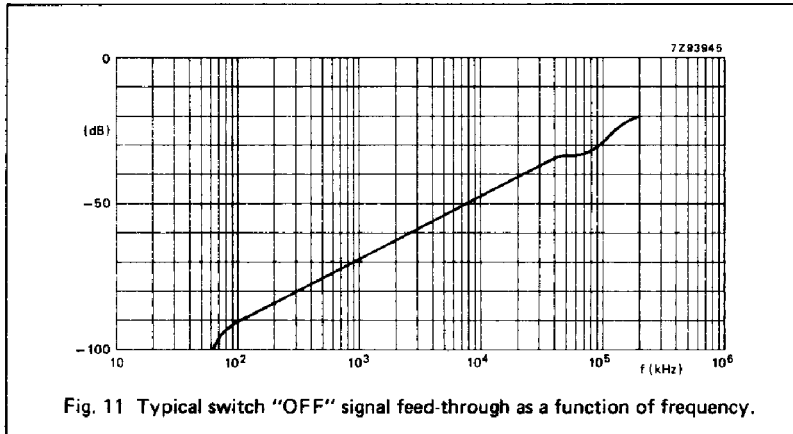

Note to Figs 11 and 12  
Test conditions:  
 $V_{CC} = 4.5 \text{ V}$ ;  $GND = 0 \text{ V}$ ;  
 $R_L = 50 \Omega$ ;  $R_{source} = 1 \text{ k}\Omega$ .

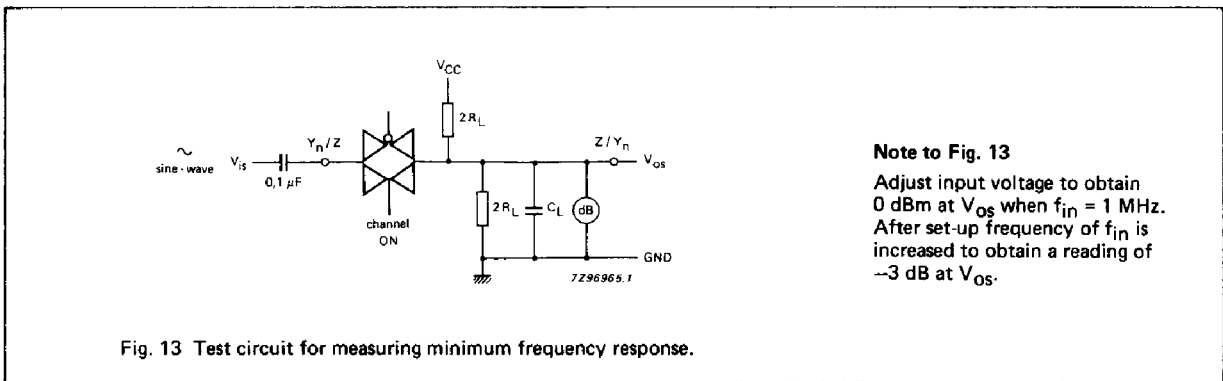

Note to Fig. 13  
Adjust input voltage to obtain  
0 dBm at  $V_{os}$  when  $f_{in} = 1 \text{ MHz}$ .  
After set-up frequency of  $f_{in}$  is  
increased to obtain a reading of  
-3 dB at  $V_{os}$ .

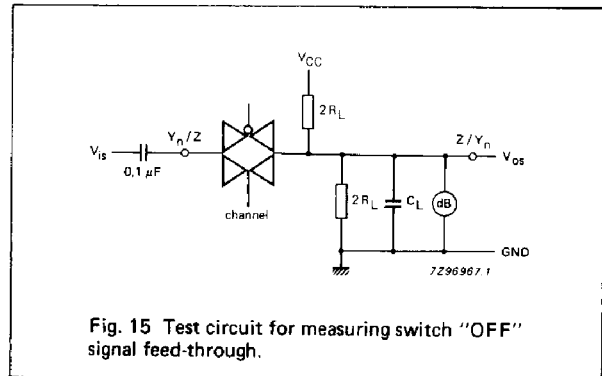
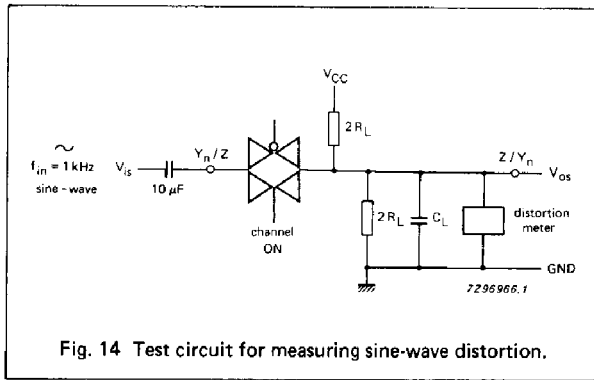

AC WAVEFORMS

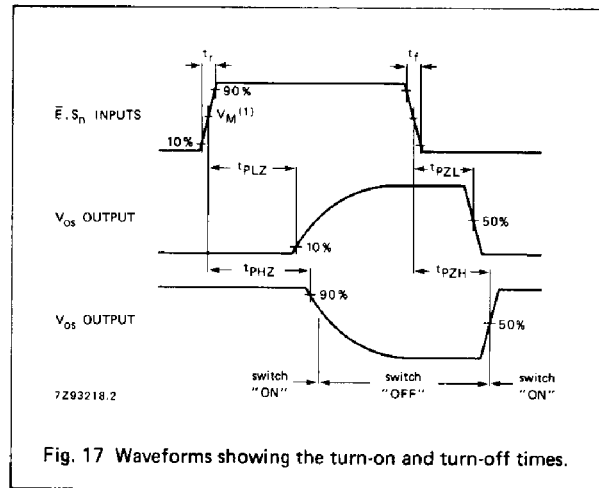
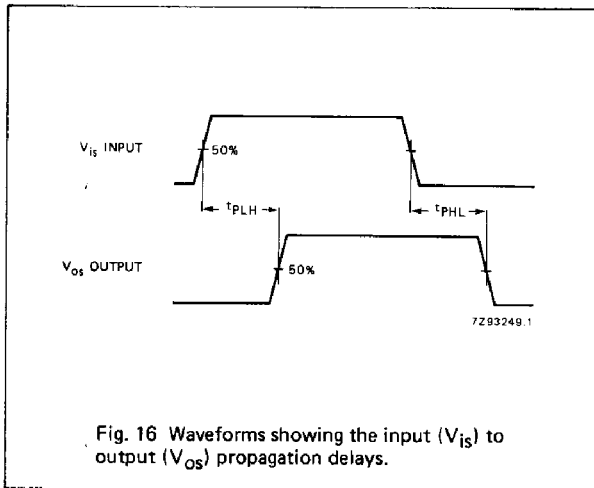

Note to Fig. 17

- (1) HC :  $V_M = 50\%$ ;  $V_I = \text{GND to } V_{CC}$ .
- HCT:  $V_M = 1.3 \text{ V}$ ;  $V_I = \text{GND to } 3 \text{ V}$ .

TEST CIRCUIT AND WAVEFORMS

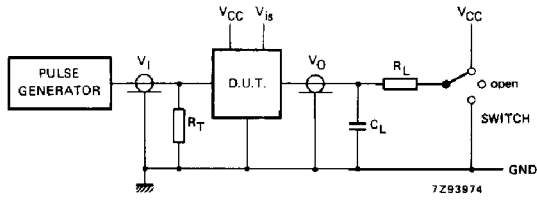

Conditions

TEST	SWITCH	V <sub>is</sub>
tpZH	GND	V <sub>CC</sub>
tpZL	V <sub>CC</sub>	GND
tpHZ	GND	V <sub>CC</sub>
tpLZ	V <sub>CC</sub>	GND
others	open	pulse

Fig. 18 Test circuit for measuring AC performance.

Definitions for Figs 18 and 19:

C<sub>L</sub> = load capacitance including jig and probe capacitance (see AC CHARACTERISTICS for values).

R<sub>T</sub> = termination resistance should be equal to the output impedance Z<sub>O</sub> of the pulse generator.

t<sub>r</sub> = t<sub>f</sub> = 6 ns, when measuring f<sub>max</sub>, there is no constraint on t<sub>r</sub>, t<sub>f</sub> with 50% duty factor.

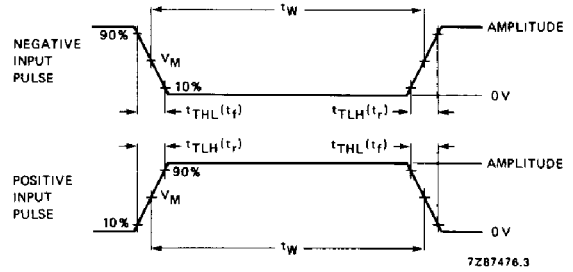

Fig. 19 Input pulse definitions.

FAMILY	AMPLITUDE	V <sub>M</sub>	t <sub>r</sub> ; t <sub>f</sub>	
			f <sub>max</sub> ; PULSE WIDTH	OTHER
74HC	V <sub>CC</sub>	50%	< 2 ns	6 ns
74HCT	3.0 V	1.3 V	< 2 ns	6 ns