

# Selecting temperature sensors for system measurement and protection

*A number of technologies are available for designers who need to measure temperature within a system. Thermistors, thermocouples, RTDs, and temperature-sensor ICs each have advantages and disadvantages in any given situation. This article compares the most popular temperature-sensing technologies and discusses the suitability of each for monitoring common targets such as PC boards, ambient air, and high-power circuits such as CPUs and FPGAs.*

## Temperature-sensing technologies

Sensors are often used within electronic systems to monitor temperature and provide protection from excessive temperature excursions. The most common technologies for use within systems are listed below.

**Thermocouples** are made by joining two wires of dissimilar metals. The point of contact between the wires generates a voltage that is approximately proportional to temperature. Characteristics include wide temperature range (up to 1250°C), low-cost, very low output voltage (on the order of 40µV per °C for type K), reasonable linearity, and moderately complex signal conditioning (cold-junction compensation and amplification). There are several thermocouple types, which are designated by letters. The most popular is type K. Maxim manufactures ICs (MAX6674 and MAX6675) that perform the signal conditioning functions for type-K thermocouples, simplifying the design task and significantly reducing the number of components required to amplify, cold-junction compensate, and digitize the thermocouple's output. Thermocouples are available in probes and with bare leads.

**RTDs** are essentially resistors (often made from platinum wire) whose resistance varies with temperature. Characteristics include wide temperature range (up to 750°C), excellent accuracy and repeatability, reasonable linearity, and the need for signal conditioning. Signal conditioning for an RTD usually consists of a precision current source and a high-resolution ADC. Cost can be

high. RTDs are available in probes, in surface-mount packages, and with bare leads.

**Thermistors** are temperature-dependent resistors, usually molded from conductive materials. The most common thermistors have a negative temperature coefficient (NTC) of resistance. Characteristics include moderate temperature range (up to 150°C), low-to-moderate cost (depending on accuracy), poor but predictable linearity, and the need for some signal conditioning. Thermistors are available in probes, in surface-mount packages, with bare leads, and in a variety of specialized packages. Maxim manufactures ICs that convert thermistor resistance to digital form.

**IC temperature sensors** are complete, silicon-based sensing circuits with either analog or digital outputs. Characteristics include moderate temperature range (up to about 150°C), low cost, excellent linearity, and additional features like signal conditioning, comparators, and digital interfaces. Digital formats are numerous and include 3-wire and 4-wire (such as SPI™), 2-wire (I<sup>2</sup>C™ and SMBus™), and single-wire (1-Wire®, PWM, frequency, and period). Note that signal conditioning, analog-to-digital conversion, and thermostatic functions all add costs to the other sensing technologies, but are normally included within sensor ICs. IC temperature sensors are available primarily in surface-mount packages.

## Choosing the proper temperature sensor for system-measurement targets

Picking the right sensor technology begins with understanding the characteristics and requirements of the target whose temperature needs to be measured. Some common temperature-measurement targets are listed below and are summarized in **Table 1**.

### PC board

Surface-mount sensors are best for PC board measurement. RTDs, thermistors, and IC sensors are available in surface-mount packages and temperature ranges that are compatible with sensing the temperature of a PC board. RTDs are quite accurate and produce highly repeatable measurements, but can be costly compared to thermistors and ICs. Thermistors are very nonlinear, but the nonlinearity is predictable. When used over a narrow tempera-

SPI is a trademark of Motorola, Inc.  
Purchase of I<sup>2</sup>C components of Maxim Integrated Products, Inc., or one of its sublicensed Associated Companies, conveys a license under the Philips I<sup>2</sup>C Patent Rights to use these components in an I<sup>2</sup>C system, provided that the system conforms to the I<sup>2</sup>C Standard Specification as defined by Philips.  
SMBus is a trademark of Intel Corporation.  
1-Wire is a registered trademark of Dallas Semiconductor, Inc.

**Table 1. Optimum sensor types for system-temperature monitoring**

Measurement Target	Best Sensor Types	Advantages	Disadvantages
PC Board	IC (analog)	Cost, linearity	—
	IC (digital)	Cost, digital output, linearity	—
	Thermistor	Cost	Nonlinearity
	RTD	Repeatability	Cost
Air	Thermistor	Cost, low thermal mass	Nonlinearity
	Thermocouple	Cost, low thermal mass	Signal conditioning (increases cost)
	RTD	Repeatability	Cost
	IC (analog or digital)	Cost, linearity	Difficult to isolate from PC board temperature
CPU, FPGA, Power Device, Module, etc. (measured under or near device)	IC (analog)	Cost, linearity	—
	IC (digital)	Cost, digital output, linearity	—
	Thermistor	Cost	Nonlinearity
	RTD	Repeatability	Cost
CPU, FPGA, Power Device, Module, etc. (contact)	Thermistor	Cost, low thermal mass	Nonlinearity
	Thermocouple	Cost, low thermal mass	Signal conditioning (increases cost)
	RTD	Repeatability	Cost
CPU, FPGA, Power Device, Module, etc. (with thermal diode)	IC (remote digital temperature sensor)	Linearity, digital output, response time, accuracy	—

ture range, they can often be linearized reasonably well with just an external resistor or two. If accuracy is not critical, thermistors can be inexpensive; but, precision thermistors can be moderately expensive. The system cost and complexity can increase significantly if linearization calculations or lookup tables must be used. ICs have excellent linearity and additional features, such as digital interface or thermostat functions. These features usually give them the edge over other sensor technologies in terms of system cost, design complexity, and performance when measuring PC board temperature.

One of the keys to measuring PC board temperature accurately is positioning the sensor in the right place. It is common to measure the temperature of a specific component or group of components, either to ensure that the temperature does not exceed the safe operating range, or to compensate for temperature-induced changes in a component’s performance. When location of the sensor is critical, look for temperature sensors in small packages, such as SOT23s, that can be easily placed in the appropriate location without disturbing the layout. Digital outputs are useful when sensors need to be located in sites that may be electrically noisy or far from the other temperature-related circuitry.

**Ambient air**

Ambient-air temperature is difficult to measure because the sensor’s temperature must be influenced by the air, but isolated from other components (PC board, power

supply, CPU) that might be at a different temperature. Thermistors, thermocouples, and RTDs are available on long leads that isolate the sensing elements from the PC board temperature. If the leads are long enough, the sensing element will be at the ambient temperature, while the leads are connected to the PC board, which is probably at a different temperature. ICs are usually difficult to use for measuring ambient temperature because the best thermal path for an IC sensor is through its leads, which are at the same temperature as the PC board. If the PC board is not at ambient temperature (for example, if it contains components that dissipate enough power to raise its temperature), the IC will not measure ambient temperature. Note that even conventional IC packages, such as TO92s, that raise the IC sensor above the PC board conduct heat so well through their leads that the measured temperature is effectively equal to the PC board temperature. However, because they have additional system features, such as digital outputs or thermostat functions, IC temperature sensors are sometimes used for ambient-air temperature sensing. This is usually done by placing them on small “satellite” PC boards that are at ambient temperature. ICs are also available that help with signal conditioning of other types of sensors. These ICs include ADCs and amplifiers for RTDs, thermistor-to-digital converters such as the MAX6691, and thermocouple-to-digital converters such as the MAX6675 (Figure 1).

## CPU, graphics processor, FPGA, power device, module, etc.

The temperature of a high-power component can often be measured with a surface-mount sensor (thermistor, IC, or RTD) near or under the device. If this is impractical, or if the device has a heat sink or some other surface that must be measured, sensors with long leads (thermocouples, RTDs, and thermistors) can be placed in contact with the surface to be measured. If the temperature to be measured is more than approximately 150°C, a thermocouple or RTD is the best choice. Near or above 750°C, thermocouples become the only choice.

## CPU, graphics processor, FPGA, power device, module, etc. (with on-board thermal diode)

Some components, especially high-performance ICs such as CPUs, graphics processors (GPUs), and FPGAs, include a diode-connected bipolar transistor for sensing temperature. Because the thermal-sensing transistor is on the IC die, measurement accuracy is far better than with other sensing technique and thermal time constants are quite small.

Maxim manufactures several ICs that are specifically designed to accurately measure the temperature of a thermal diode and convert it directly to digital form. Some of these ICs measure a single thermal diode, while

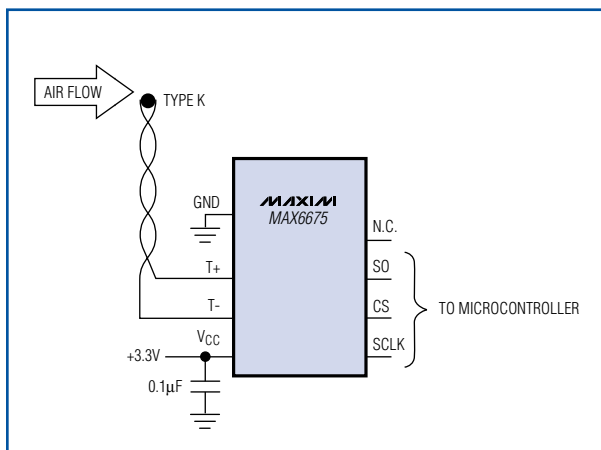

Figure 1. Using a thermocouple to sense ambient temperature, the MAX6675 provides cold-junction compensation and converts the output of the thermocouple directly to digital form.

others measure as many as four. The signal levels are small (on the order of 200µV per °C), but still larger than those of thermocouples. Internal and external filtering, combined with reasonable care in layout, allow remote diode sensors to be widely used in electrically noisy equipment such as computers, servers, and workstations. Most of these ICs provide additional functions to protect the target IC, such as overtemperature alarm pins that can be used to shut the system down if temperature exceeds the safe operating limits of the target. An example of a remote diode sensor (MAX6642) is shown in **Figure 2**. This IC measures the thermal diode temperature and its own temperature up to 150°C, and also provides an overtemperature alarm output with a trip temperature that is programmable over the SMBus.

## Conclusion

There are several different temperature-sensing technologies available for the system designer. The right technology depends on the target temperature to be measured, and also on other system requirements such as cost, circuit size, and design time. Maxim's comprehensive selection of temperature-sensing ICs can help the designer solve common temperature-measurement problems with excellent performance and low overall cost.

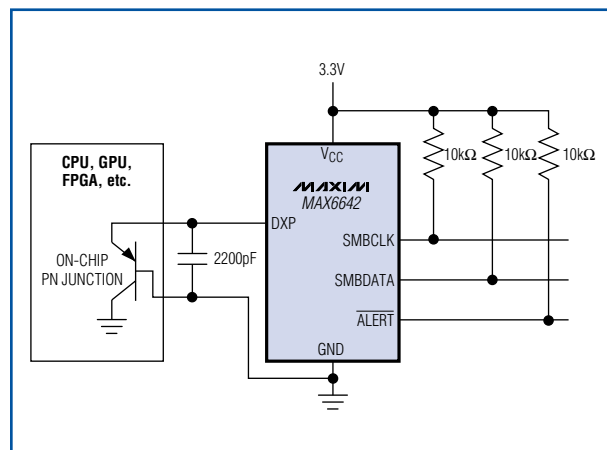

Figure 2. The MAX6642 is the world's smallest remote temperature sensor. It has an ALERT pin that may be used as an interrupt or as a system shutdown signal to protect the target IC from damage due to overheating.