

## High Input Voltage Adjustable 3-Terminal Linear Regulator

### Features

- 13.2V to 100V Input Voltage Range
- Stable with 100nF output capacitor
- Adjustable 1.20V to 88V output regulation
- 5% reference voltage tolerance
- Output current limiting, 50mA min.
- 10 $\mu$ A typical ADJ current
- Over temperature protection
- Available in 3 different packages

### Applications

- DC/DC SMPS startup circuits
- Adjustable high voltage constant current sources
- Industrial Controls
- Motor Controls
- Battery Powered Systems
- Power Supplies
- Telecom Applications
- LED Drivers
- Automotive Applications

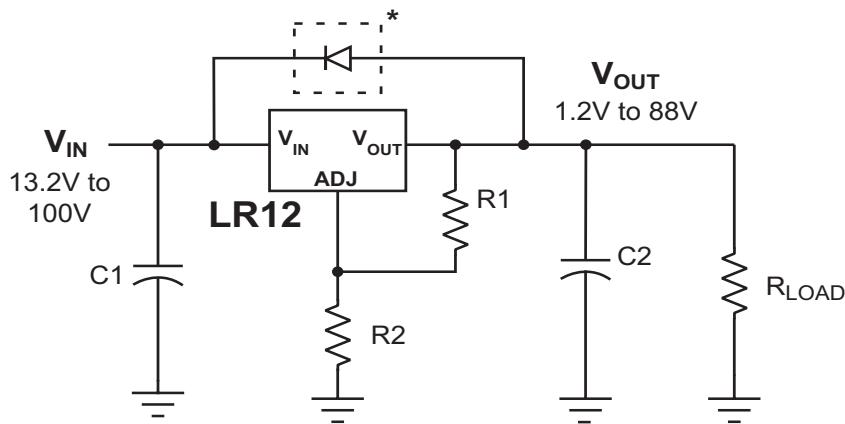
### General Description

The Supertex LR12 is a high voltage, low output current, adjustable linear regulator. It has a wide operating input voltage range of 13.2V to 100V. The output voltage can be adjusted from 1.20V to 88V provided that the input voltage is at least 12V greater than the output voltage. The output voltage can be adjusted by means of two external resistors  $R_1$  and  $R_2$  as shown in the typical application circuits. The LR12 regulates the voltage difference between  $V_{OUT}$  and ADJ pins to a nominal value of 1.20V. The 1.20V is amplified by the external resistor ratio  $R_1$  and  $R_2$ . An internal constant bias current of typically 10 $\mu$ A is connected to the ADJ pin. This increases  $V_{OUT}$  by a constant voltage of 10 $\mu$ A times  $R_2$ .

The LR12 has current limiting and temperature limiting. The output current limit is 100mA maximum and the minimum temperature limit is 125 $^{\circ}$ C. An output short circuit current will therefore be limited to 100mA maximum. When the junction temperature reaches its temperature limit, the output current and/or output voltage will decrease to keep the junction temperature from exceeding its temperature limit. For SMPS start-up circuit applications, the LR12 turns off when an external voltage greater than the output voltage of the LR12 is applied to  $V_{OUT}$  of the LR12. To maintain stability, a bypass capacitor of 100nF or larger and a minimum DC output current of 500 $\mu$ A are required.

The device is available in TO-92, SO-8, and TO-252 (D-PAK) packages.

### LR12 Typical Application



\*Required for conditions where  $V_{IN}$  is less than  $V_{OUT}$ .

## Ordering Information

Package Options		
SO-8	TO-252 <sup>1</sup>	TO-92
LR12LG	LR12K4	LR12N3
LR12LG-G	LR12K4-G	LR12N3-G

Notes:

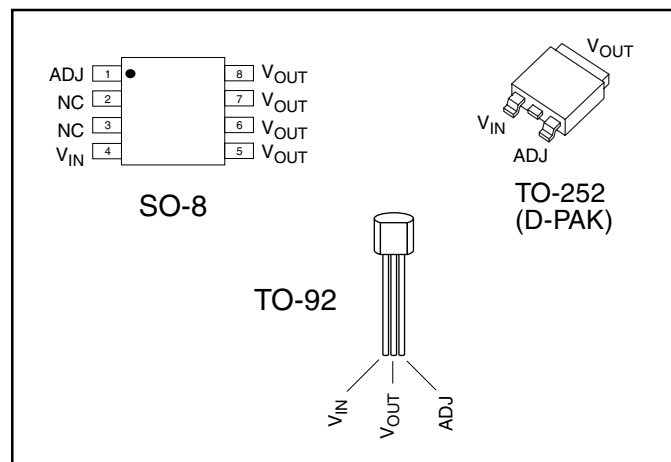
- TO-252 supplied on 2000 piece carrier tape reels only  
-G indicates package is RoHS compliant "Green"



## Absolute Maximum Ratings

$V_{IN-ADJ}$	-0.5V to +120V
$V_{OUT-ADJ}$	-10V to +10V
$V_{IN} - V_{OUT}$	-0.5V to +120V
Operating Ambient Temperature Range	-40°C to +85°C
Operating Junction Temperature Range	-40°C to +125°C
Storage Temperature Range	-65°C to +150°C

## Pin Configurations



## Electrical Characteristics

Test conditions unless otherwise specified:  $-40^{\circ}\text{C} < T_A < 85^{\circ}\text{C}$ .

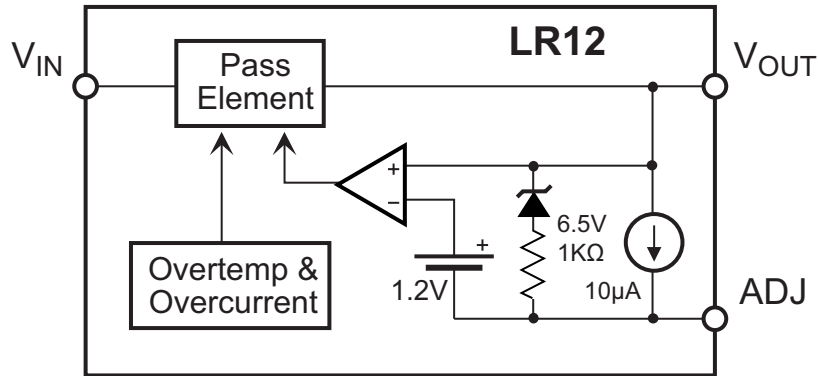
Symbol	Parameter	Min	Typ	Max	Units	Test Conditions
$V_{IN} - V_{OUT}$	Input to Output Voltage Difference	12		98.8	V	
$V_{OUT}$	Overall Output Voltage Regulation	1.14	1.20	1.26	V	$13.2\text{V} < V_{IN} < 100\text{V}$ , $R_1 = 2.4\text{K}\Omega$ , $R_2 = 0$
$\Delta V_{OUT}$	Line Regulation		0.003	0.03	%/V	$15\text{V} < V_{IN} < 100\text{V}$ , $V_{OUT} = 5\text{V}$ , $I_{OUT} = 0.5\text{mA}$
$\Delta V_{OUT}$	Load Regulation		1.4	3.0	%	$V_{IN} = 15\text{V}$ , $V_{OUT} = 5\text{V}$ , $0.5\text{mA} < I_{OUT} < 50\text{mA}$
$\Delta V_{OUT}$	Temperature Regulation	-1		+1	%	$V_{IN} = 15\text{V}$ , $V_{OUT} = 5\text{V}$ , $I_{OUT} = 10\text{mA}$ , $-40^{\circ}\text{C} < T_A < 85^{\circ}\text{C}$
$I_{OUT}$	Output Current Limit	50		100	mA	$T_J < 85^{\circ}\text{C}$ , $V_{IN} - V_{OUT} = 12\text{V}$
$I_{OUT}$	Output Current Limit			0.5	mA	$T_J > 125^{\circ}\text{C}$ , $V_{IN} - V_{OUT} = 100\text{V}$
$I_{OUT}$	Minimum Output Current	0.5			mA	Includes $R_1$ and load current
$I_{ADJ}$	Adjust Output Current	5	10	15	$\mu\text{A}$	
C2	Minimum Output Load Capacitance	100			nF	
$DV_{OUT}/DV_{IN}$	Ripple Rejection Ratio	50	60		dB	120Hz, $V_{OUT} = 5\text{V}$
$T_{LIMIT}$	Junction Temperature Limit	125			$^{\circ}\text{C}$	

## Thermal Characteristics

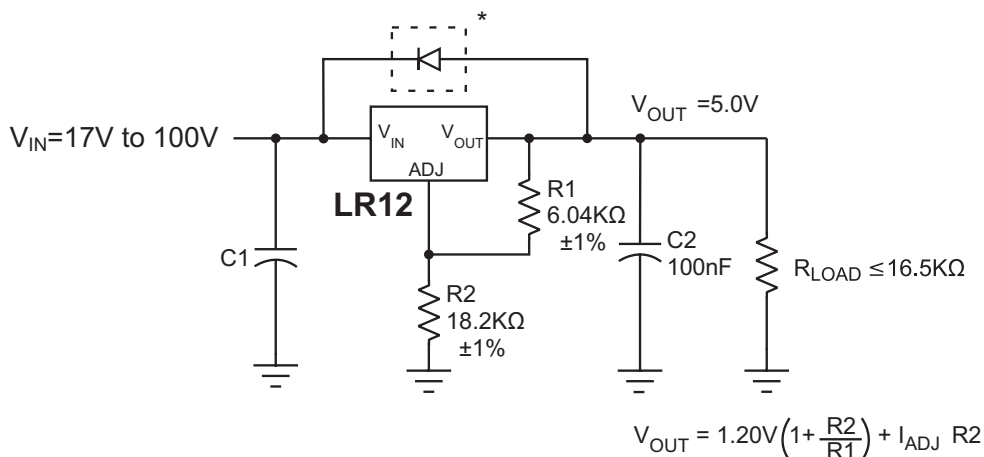
Package	Power Dissipation @ $T_A=25^{\circ}\text{C}$	$\theta_{\text{JC}}$ $^{\circ}\text{C/W}$	$\theta_{\text{JA}}$ $^{\circ}\text{C/W}$
TO-92	0.6W	125	170
SO-8	1.8W	—	55 <sup>†</sup>
TO-252	2.0W	6.25	50 <sup>†</sup>

<sup>†</sup> Mounted on FR4 board, 25mm x 25mm x 1.57mm.  
Significant  $P_D$  increase possible on ceramic substrate.

## Functional Block Diagram

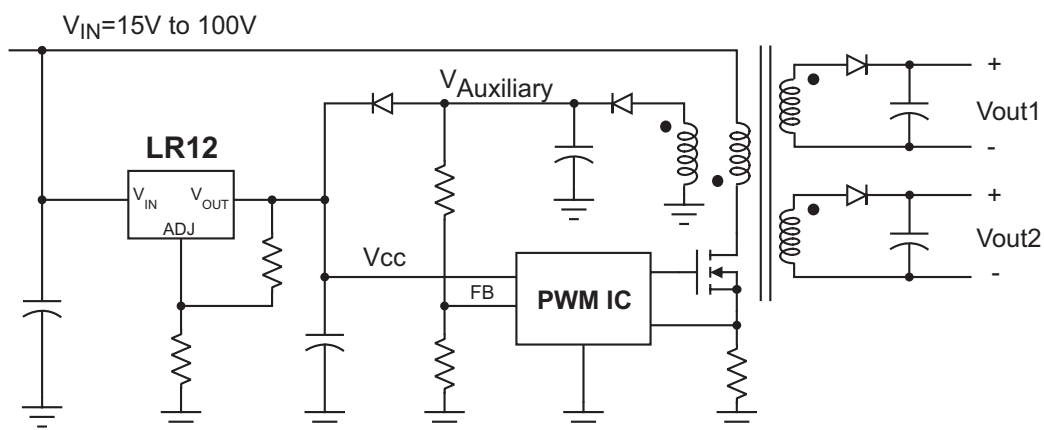


Typical Application Circuits

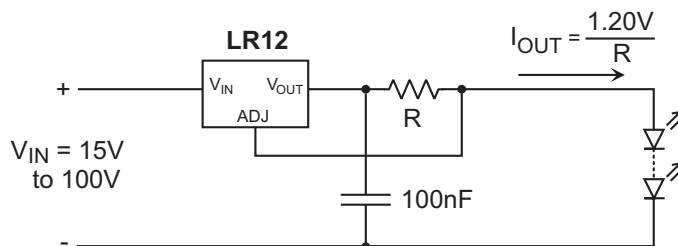


**Figure 1: High Input Voltage, 5.0V Output Linear Regulator**

\* Required for conditions where  $V_{IN}$  is less than  $V_{OUT}$ .



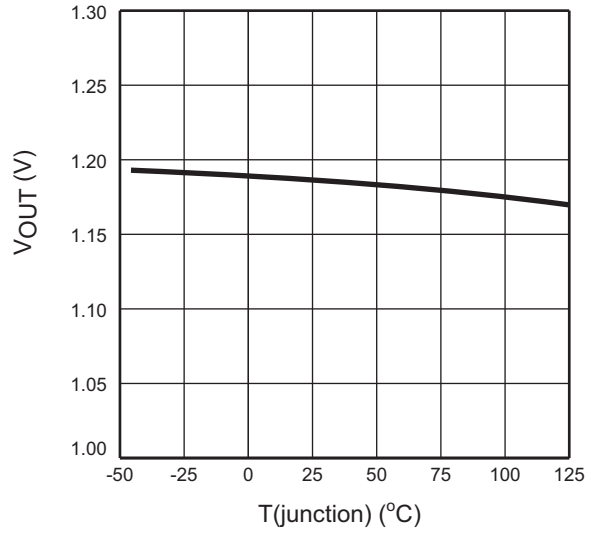
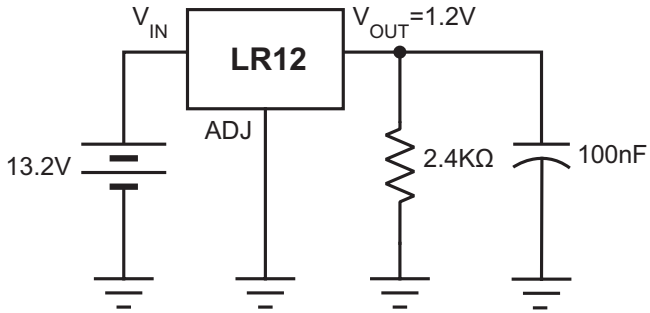
**Figure 2: SMPS Start-Up Circuit**



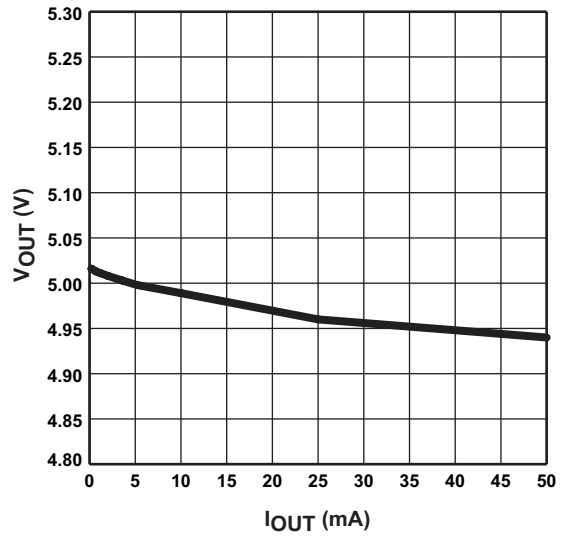
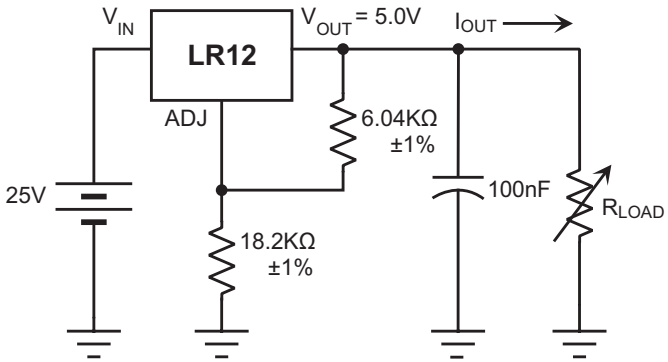
**Figure 3: High Voltage Adjustable Constant Current Source**

Typical Performance Curves

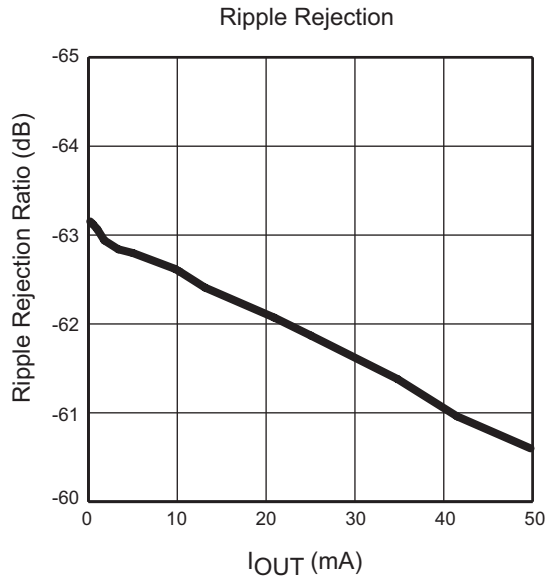
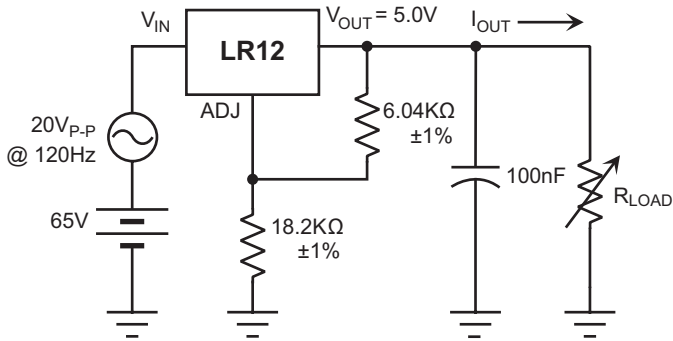
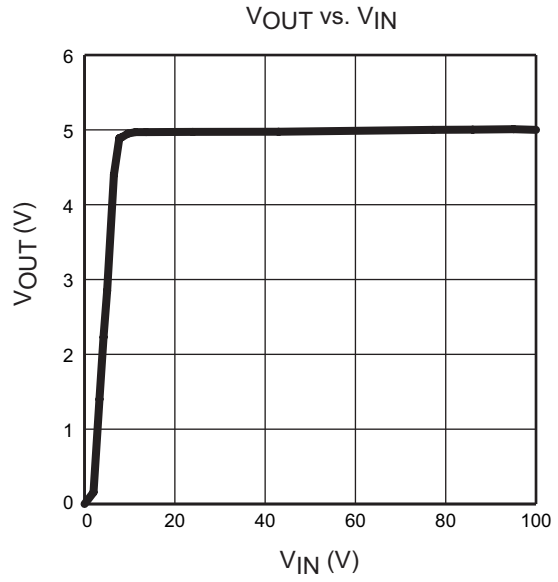
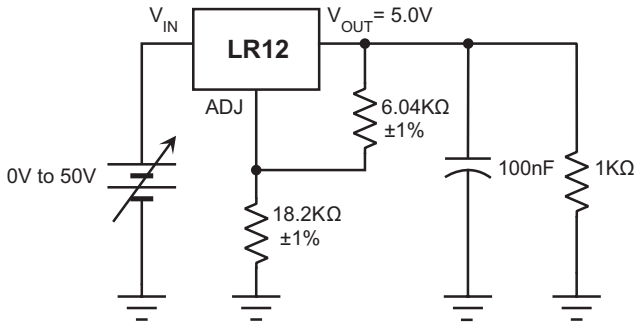
Temperature Variation



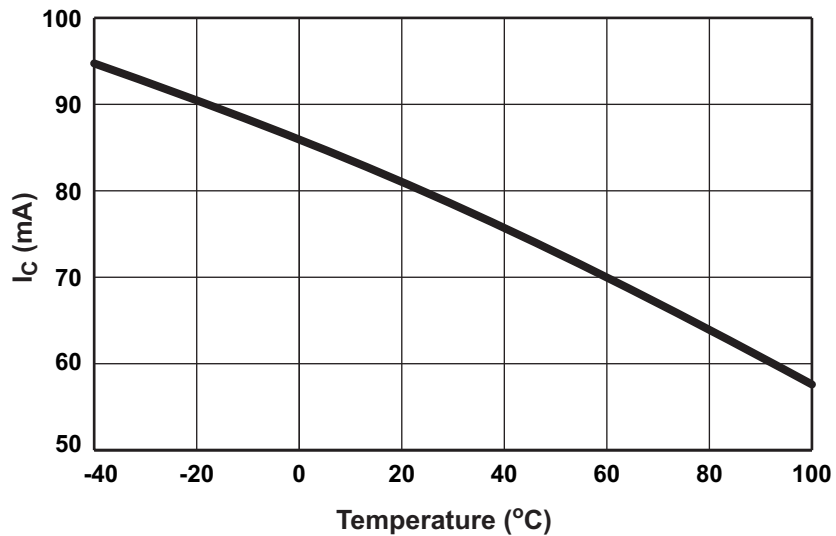
Load Regulation



# Typical Performance Curves

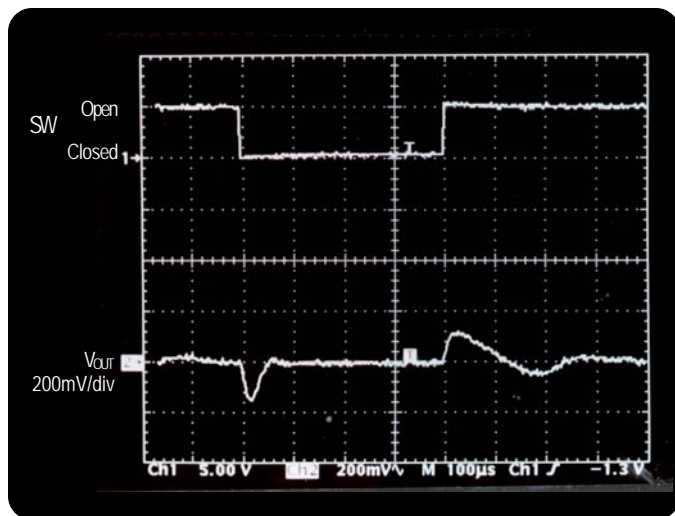
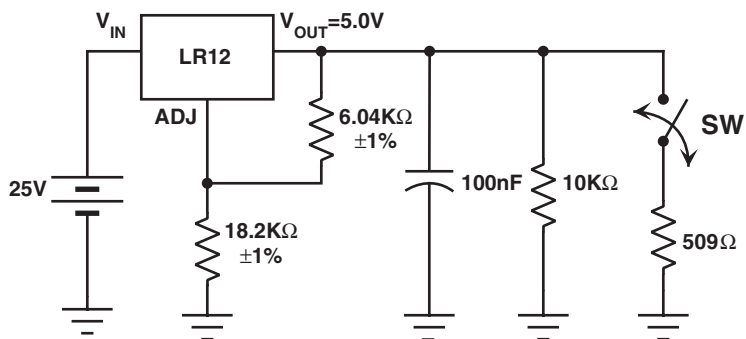


## Current Limit



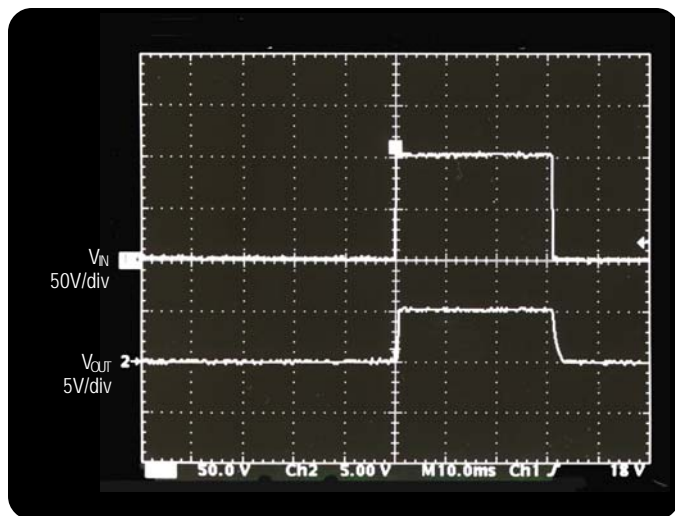
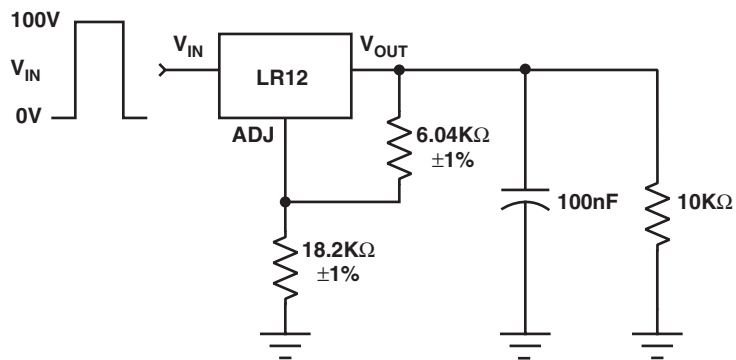
# Typical Performance Curves

## Load Transient Response

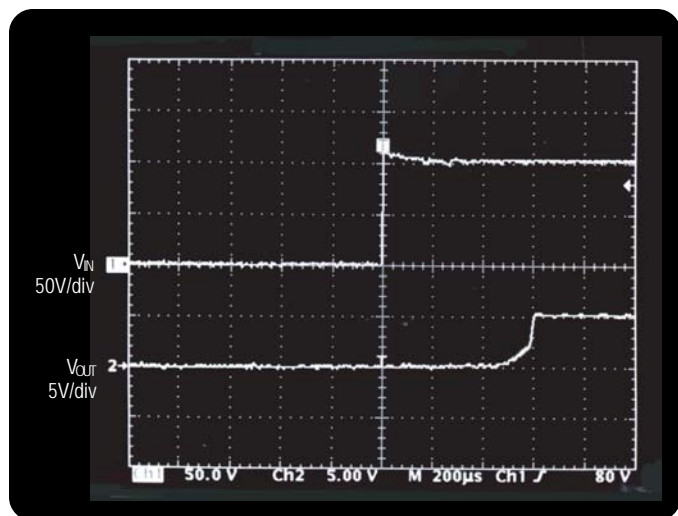


Load Transient Response, Load = 509Ω

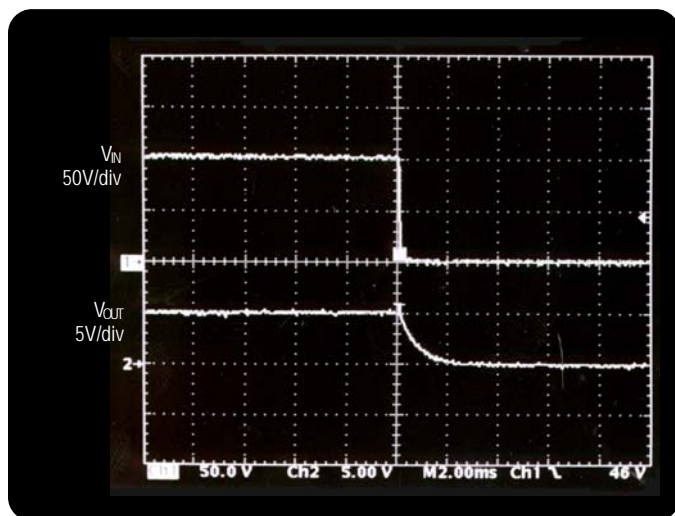
## Line Transient Response



Line Turn On/Off Response

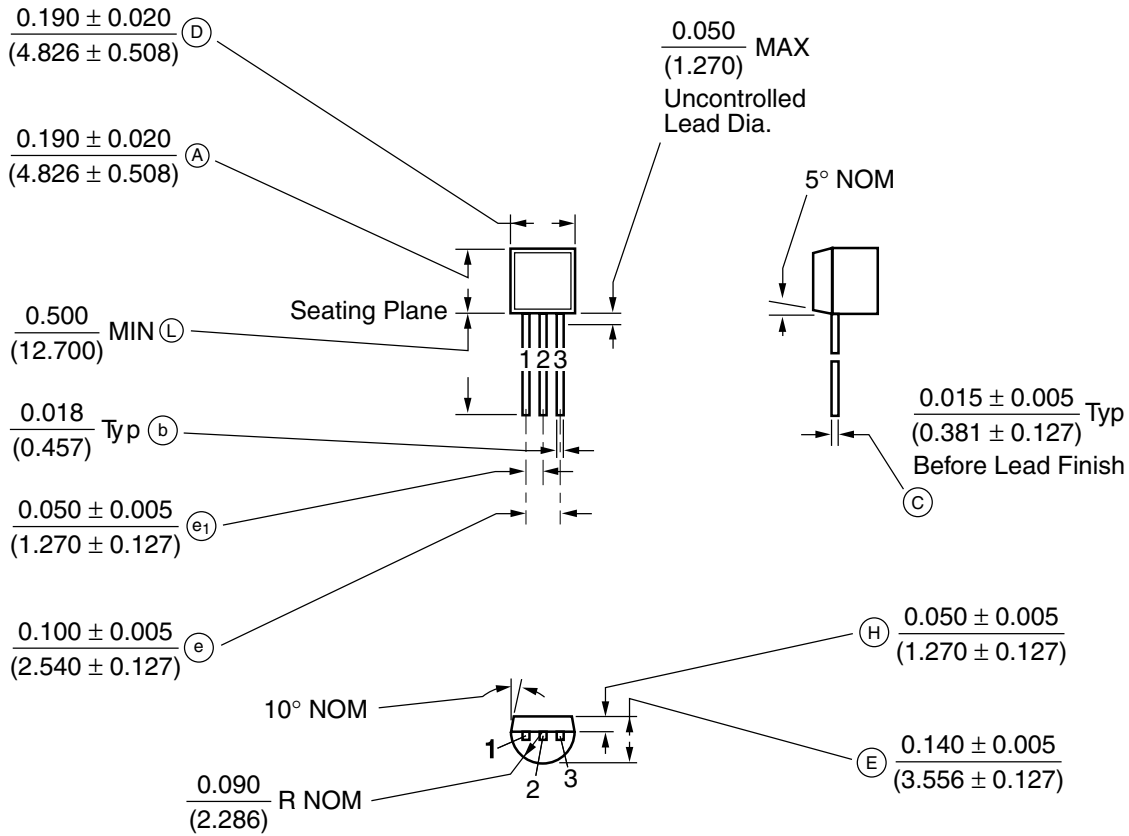


Line Power Up Transient

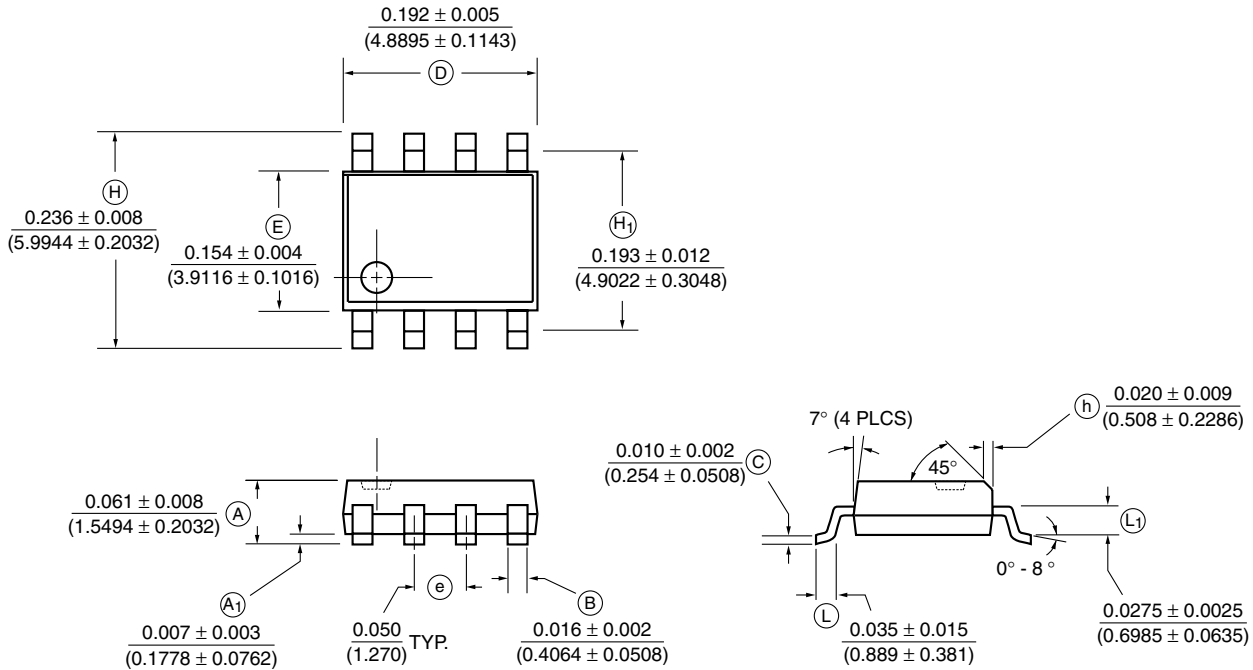


Line Power Down Transient

### 3 Lead TO-92 Plastic Package (N3)



### 8-Lead Small Outline Package (LG, TG)

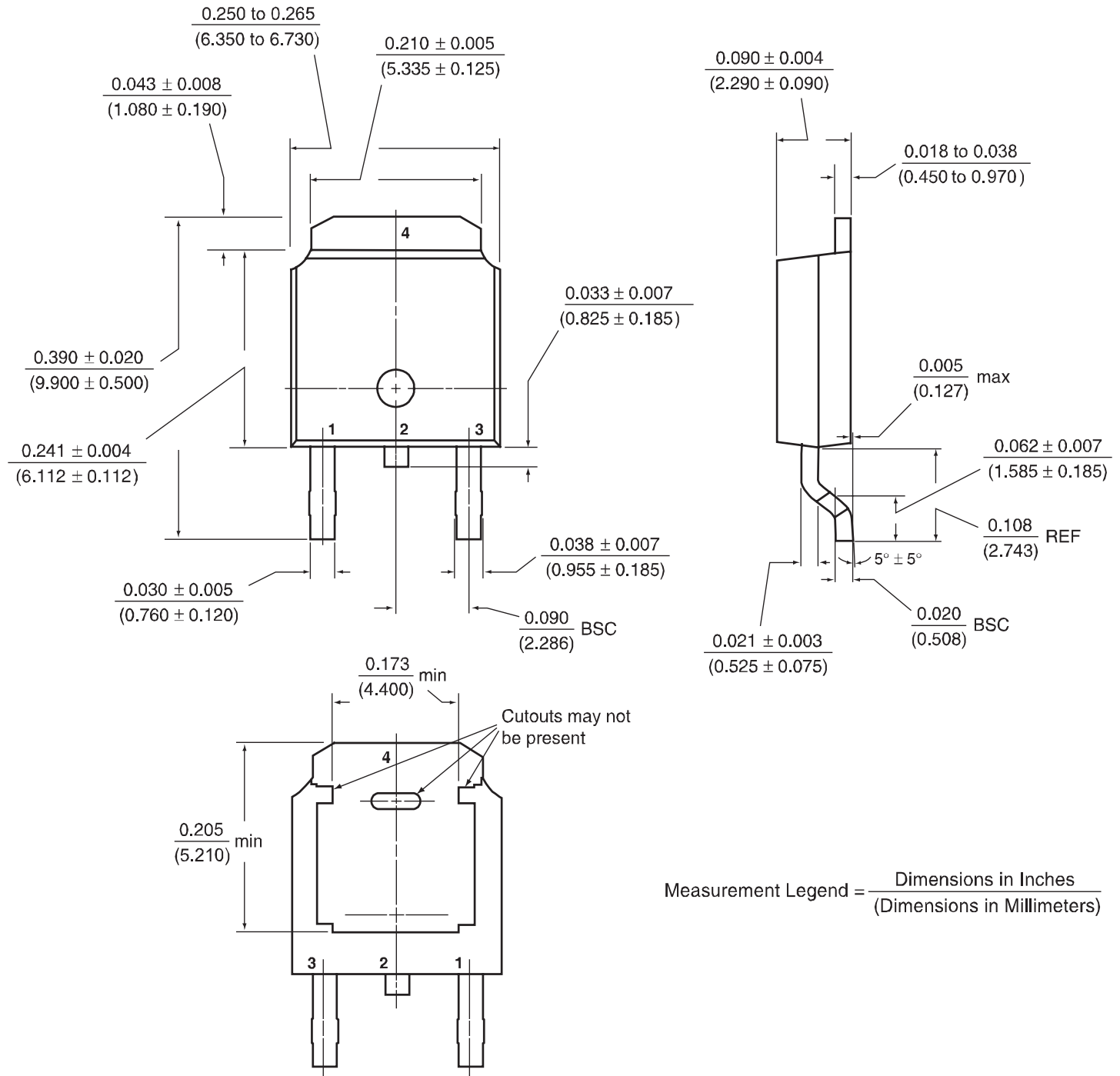


Note: Circle (e.g. (B)) indicates JEDEC Reference.

Measurement Legend =  $\frac{\text{Dimensions in Inches}}{\text{(Dimensions in Millimeters)}}$



3-Lead TO-252 (D-PAK) Package (K4)



**Supertex inc.** does not recommend the use of its products in life support applications and will not knowingly sell its products for use in such applications unless it receives an adequate "products liability indemnification insurance agreement". **Supertex** does not assume responsibility for use of devices described and limits its liability to the replacement of the devices determined defective due to workmanship. No responsibility is assumed for possible omissions or inaccuracies. Circuitry and specifications are subject to change without notice. For the latest product specifications, refer to the **Supertex** website: <http://www.supertex.com>. For complete liability information on all **Supertex** products, refer to the most current databook.