

# Current Transducer HTA 100..1000-S

$$I_{PN} = 100..1000 \text{ A}$$

For the electronic measurement of DC, AC and pulsed currents, with a galvanic isolation between the primary (high power) circuit and the secondary (electronic) circuit.

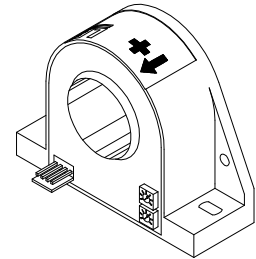

## Electrical data

Primary nominal current rms $I_{PN}$ (A)	Primary current measuring range $I_{PM}$ (A)	Type	RoHS since date code
100	± 300	HTA 100-S	46179
200	± 600	HTA 200-S	46170
300	± 900	HTA 300-S	46097
400	± 1000	HTA 400-S	46100
500	± 1000	HTA 500-S	46083
600	± 1000	HTA 600-S	46222
1000	± 1000	HTA 1000-S	46118

$\hat{I}_P$	Overload capability	30,000	A
$V_{OUT}$	Output voltage (Analog) @ ± $I_{PN}$	± 4	V
$R_L$	Load resistance $T_A = 0 \dots +70^\circ\text{C}$	> 1	kΩ
	$T_A = -25 \dots +85^\circ\text{C}$	> 3	kΩ
$V_C$	Supply voltage (± 5%)	± 15	V
$I_C$	Current consumption	< 25	mA
$V_b$	Rated isolation voltage rms <sup>1)</sup>	500	V
$V_d$	Rms voltage for AC isolation test, 50 Hz, 1 min	3	kV
$R_{is}$	Isolation resistance @ 500 $V_{DC}$	> 500	MΩ

## Accuracy - Dynamic performance data

<b>X</b>	Accuracy <sup>2)</sup> @ $I_{PN}$ , $T_A = 25^\circ\text{C}$ , @ ± 15 V	± 1	%
<b>e<sub>L</sub></b>	Linearity error <sup>2)</sup> (0 .. ± $I_{PN}$ )	± 0.5	%
<b>V<sub>OE</sub></b>	Electrical offset voltage @ $I_P = 0$ , $T_A = 25^\circ\text{C}$	< ± 10	mV
<b>V<sub>OH</sub></b>	Hysteresis offset voltage @ $I_P = 0$ , after an excursion of 3 x $I_{PN}$	< ± 10	mV
<b>TCV<sub>OE</sub></b>	Temperature coefficient of $V_{OE}$ $T_A = -25 \dots +85^\circ\text{C}$	< ± 1	mV/K
<b>TCV<sub>OUT</sub></b>	Temperature coefficient of $V_{OUT}$ $T_A = -25 \dots +85^\circ\text{C}$	< ± 0.05	%/K
<b>t<sub>r</sub></b>	Response time to 90 % of $I_{PN}$ step	< 3	μs
<b>di/dt</b>	di/dt accurately followed	> 50	A/μs
<b>BW</b>	Frequency bandwidth (- 3 dB) <sup>3)</sup>	DC .. 50	kHz

## General data

<b>T<sub>A</sub></b>	Ambient operating temperature	- 25 .. + 85	°C
<b>T<sub>S</sub></b>	Ambient storage temperature	- 25 .. + 85	°C
<b>m</b>	Mass	230	g
	Standards Safety	EN50178(1994)	
	EMC	EN50082-2(1992)	
		EN50081-1(1992)	
	Deviation in output when tested to EN 61000-4-3	< 25	% of $I_{PN}$

Notes : <sup>1)</sup> Overvoltage Category III, Pollution Degree 2

<sup>2)</sup> Excludes the electrical offset

<sup>3)</sup> Refer to derating curves in the technical file to avoid excessive core heating at high frequency

## Features

- Open loop transducer using Hall Effect
- Panel mounting - Horizontal or Vertical
- Insulated plastic case recognized according to UL 94-V0

## Advantages

- Very good linearity
- Very good accuracy
- Low temperature drift
- Wide frequency bandwidth
- Very low insertion losses
- High immunity to external interference
- Current overload capability
- Low power consumption
- Wide dynamic range, 100 to 1000 A in one package.

## Applications

- AC variable speed drives and servo motor drives
- Static converters for DC motor drives
- Battery supplied applications
- Uninterruptable Power Supplies (UPS)
- Switched Mode Power Supplies (SMPS)
- Power supplies for welding applications.

## Application domain

- Industrial

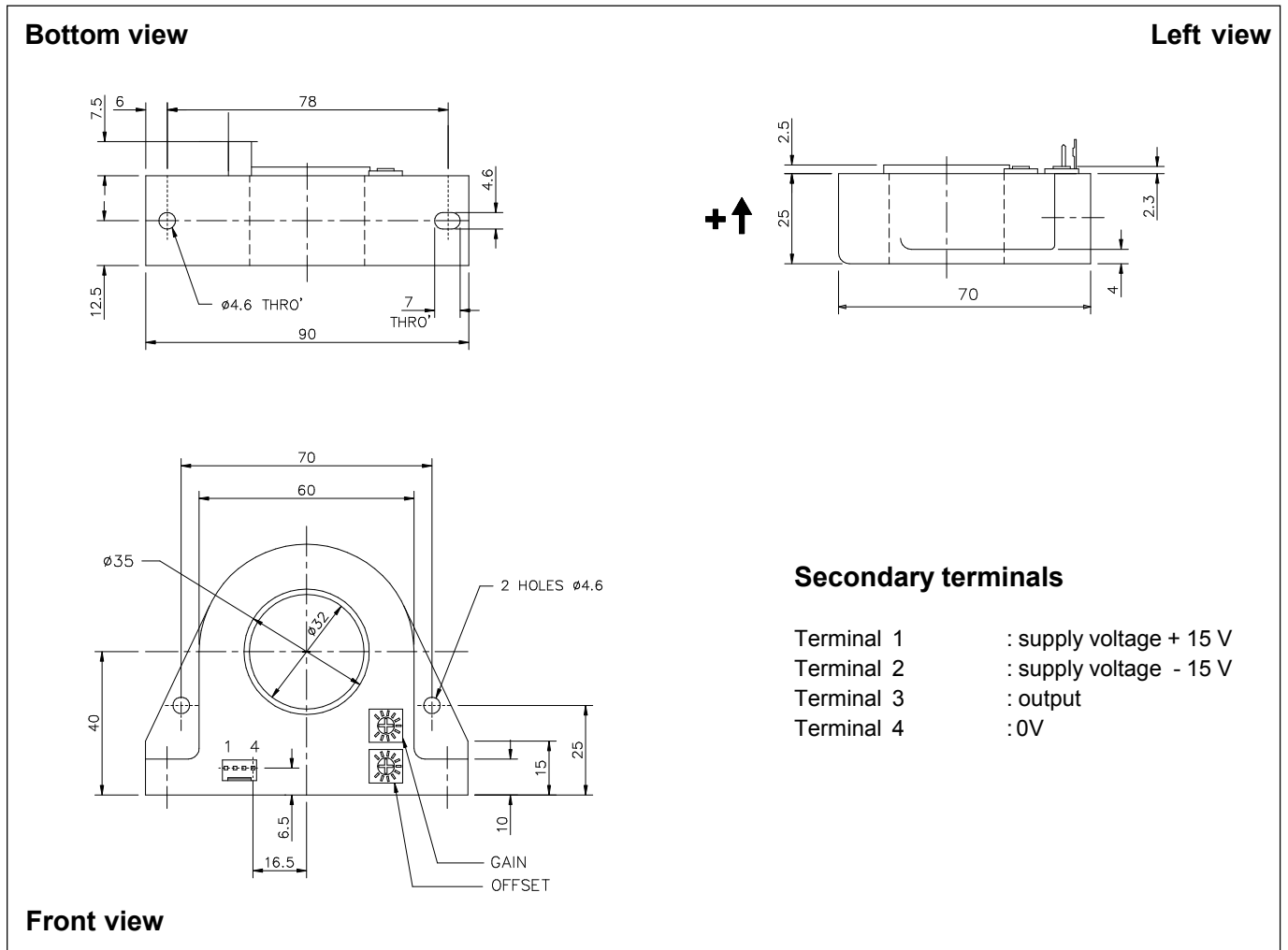
**Dimensions HTA 100..1000-S** (in mm. 1 mm = 0.0394 inch)

**Mechanical characteristics**

- General tolerance  $\pm 0.5$  mm
- Primary through-hole  $\varnothing 32$  mm
- Connection of secondary Molex 5045-04A

**Remarks**

- $V_{OUT}$  is positive when  $I_p$  flows in the direction of the arrow.
- Temperature of the primary conductor should not exceed 90°C.
- This is a standard model. For different versions (supply voltages, secondary connections, unidirectional measurements, operating temperatures, etc.) please contact us.

**Safety**

This transducer must be used in electric/electronic equipment with respect to applicable standards and safety requirements in accordance with the manufacturer's operating instructions.



Caution, risk of electrical shock

When operating the transducer, certain parts of the module can carry hazardous voltage (eg. primary busbar, power supply). Ignoring this warning can lead to injury and/or cause serious damage.

This transducer is a built-in device, whose conducting parts must be inaccessible after installation.

A protective housing or additional shield could be used. Main supply must be able to be disconnected.