

# LM5642 Evaluation Board

National Semiconductor  
Application Note 1292  
Chris Richardson  
September 2003



## Introduction

The LM5642 IC is a dual channel, current-mode, synchronous buck converter controller. It can handle input voltages of up to 36V and delivers two independent output voltages from 1.23V up to 90% of the input voltage. Current sensing can be done using a dedicated resistor or using the  $R_{DS(ON)}$  of the high-side FET. This application note describes the dedicated evaluation PCBs that are available for both methods.

## Resistor Sense PCB

The first, more common method of sensing current in current-mode controllers is with an external sense resistor, placed in series with the high-side FET of each channel. Sense resistors provide an accurate voltage as the load current passes through them, and have stable, linear resistance change with temperature. As shipped the Resistor Sense PCB is designed to deliver 1.8V on Channel 1 at a maximum current of 7A, and 3.3V on Channel 2 at a maximum current of 4A. The input voltage can vary anywhere from 5.5 to 36V. The board has been designed to be flexible and allow many other circuit configurations by replacing the original components with user selected ones. *Figure 1* shows the circuit diagram representing the standard BOM that comes with the PCB. *Table 1* lists all the components that are used for this standard configuration BOM. *Figure 2* shows the complete circuit diagram with all extra footprints.

Two SPST switches **S1** and **S2** are provided to turn the two channels of the converter on and off. The standard BOM that comes with the LM5642 Resistor Sense evaluation board uses 10m $\Omega$  current sense resistors (**R7** for Channel 1, **R15** for Channel 2) to provide independent feedback signals to the IC. The board provides additional resistor and capacitor footprints for noise filtering, ringing control, and to enable operation at low input voltages.

## Current Sense Filters

R-C filters have been added to the current sense amplifier inputs of the Resistor Sense evaluation board, comprised of components **C3**, **C4**, **C14**, **C15**, **R2**, **R6**, and **R16**. These resistors and capacitors reduce the sensitivity to switching noise, especially during high currents, load-transients, and circuits with short on-times.

## Parallel Operation

The two channels of the LM5642 Resistor Sense evaluation board can be paralleled to provide one high current rail. At the nominal switching frequency of 200kHz the converter will run 180° out-of-phase. Care must be taken when using this feature combined with the frequency synchronization, as the two channels of the converter are no longer 180° out-of-phase when the frequency is above or below 200kHz. The two feedback inputs FB1 and FB2 should be tied together by soldering a 0 $\Omega$  resistor in the position marked **J1** on the bottom side of the PCB. The two COMP pins should be tied together by soldering a 0 $\Omega$  resistor in the position **J3**. The

ON/SS1 and ON/SS2 pins must also be connected using a 0 $\Omega$  resistor in the position **J2**. One of the two SPDT switches **S1** and **S2** should be left 'ON' and the other used to turn the converter off and on. Finally, the two outputs VO1 and VO2 must be tied together by the user, external to the PCB. Only one of the two resistor divider networks (**R10/R11** or **R19/R20**) and only one of the compensation networks should be used. (**C18/C19/R22/R23**) or **C20/C21/R24/R25**.

## V<sub>DS</sub> Sense PCB

The LM5642 IC offers a second current sensing mechanism that uses the  $R_{DS(ON)}$  of the high-side FET to sense the load current. This method reduces the parts count on the BOM, however the  $R_{DS(ON)}$  of a FET is not as tightly controlled as a sense resistor, and suffers from non-linear changes in resistance with temperature. As a result, the IC is more sensitive to noise in this mode, especially at input voltages above 30V. The maximum recommended current using VDS sensing is 5A per channel. The VDS Sense board has been designed to deliver 1.8V on Channel 1 with a maximum current of 5A, and 3.3V on Channel 2 with a maximum current of 4A. *Figure 3* shows the circuit diagram representing the standard BOM that comes with the PCB. *Table 2* lists all the components that are used for this standard configuration BOM. *Figure 4* shows the complete circuit diagram with all extra footprints.

## Frequency Synchronization

A connection point labeled 'SYNC' is available on both versions of the LM5642 evaluation boards in order to adjust the switching frequency of the IC between 150 and 250kHz. Both CMOS and TTL level square wave signals can be used. The SYNC input has a minimum low-to-high transition threshold of 2.0V and a maximum high-to-low threshold of 0.8V. The SYNC pin is grounded by a 220k $\Omega$  pull-down resistor.

## Low Input Voltage Operation

When the input voltage is between 4.5V and 5.5 on either evaluation board, a 4.7 $\Omega$  resistor should be installed in position **R26**. This will ensure that V<sub>LIN5</sub> does not fall below the UVLO threshold of the IC. When **R26** is in place the input voltage must not exceed 5.5V.

## Gate Drive Current Limiting

The LM25642 IC includes powerful gate drivers which can drive small FETs at high speed, often inducing noise or ringing into the board. Slowing the gate drivers can help reduce this noise by increasing the drain current transition time. While slowing the gate drives can help suppress noise, it also increases switching losses and gate-charge losses in the top FET. Slowing of the gate drives can be accomplished with resistors in series with the CBOOT1 and CBOOT2 pins. (**R9,R18**) Placing resistors in series with the CBOOT pins will

# Gate Drive Current Limiting

(Continued)

slow the top FET rise time only. Generally the values for gate drive limiting resistors are between 1 and 5Ω. **R9** and **R18** are 0Ω by default.

## Parallel Low-Side Schottky Diode

The LM5642 evaluation boards include footprints for Schottky diodes **D4** and **D5** (SMB footprint or smaller) in parallel to the low side FETs. Placing these diodes on the PCB can improve efficiency because Schottky diodes have a lower forward voltage drop and lower reverse recovery charge than the parasitic diode of the bottom FET.

## Parallel Low-Side FET

Footprints **Q3** and **Q6** have been placed on both boards so that two SO-8 N-FETs can be placed in parallel for the low-side of each channel. Paralleling FETs reduces the

$R_{DS(ON)}$  of the system and spreads the heat dissipated by the load current over two packages. This is especially important for converters with high input voltage and low output voltage, where the low duty cycle forces the low side FET or FETs to carry the load current for a much greater percentage than the high-side FET.

## Additional Footprints

Additional footprints are provided to add more surface mount or through-hole capacitors (with 3.5 or 5mm lead spacing) in parallel to the input and output capacitors.

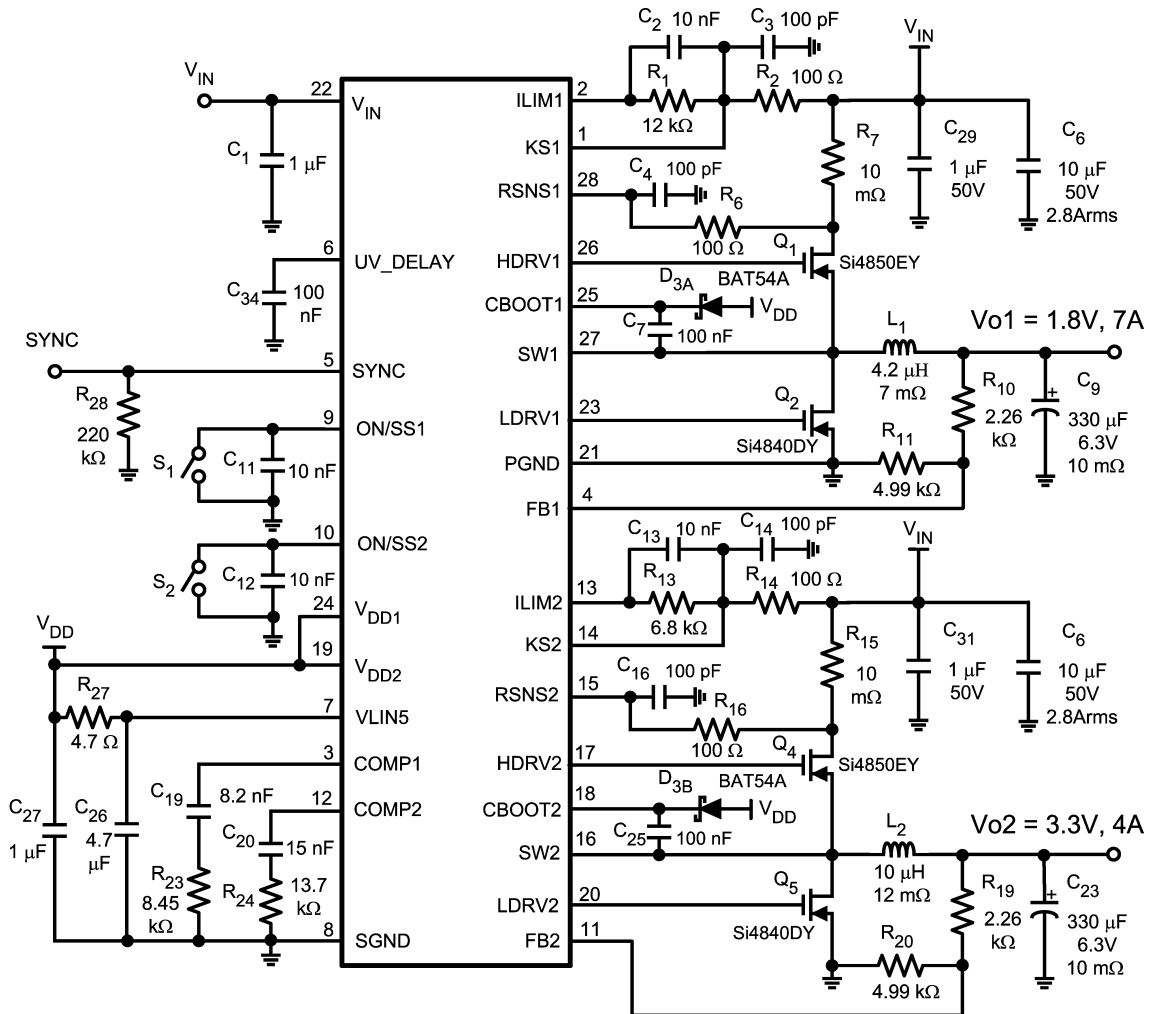

FIGURE 1. Standard Resistor Sense Circuit

20077201

**Additional Footprints** (Continued)**TABLE 1. Standard Resistor Sense Bill Of Materials**

ID	Part Number	Type	Size	Parameters	Qty	Vendor
U1	LM5642	Dual Synchronous Controller	TSSOP-28		1	NSC
Q1, Q4	Si4850EY	N-MOSFET	SO-8	60V	2	Vishay
Q2, Q5	Si4840DY	N-MOSFET	SO-8	40V	2	Vishay
D3	BAT54A	Schottky Diode	SOT-23	30V	1	ON
L1	RLF12560T-4R2N100	Inductor	12.5x12.5x 6mm	4.2 $\mu$ H, 7m $\Omega$ , 10A	1	TDK
L2	RLF12545T-100M5R1	Inductor	12.5x12.5x 4.5mm	10 $\mu$ H, 12m $\Omega$ , 5.1A	1	TDK
C1, C29, C31	C3216X7R1H105K	Capacitor	1206	1 $\mu$ F, 50V	3	TDK
C3, C4, C14, C15	VJ1206Y101KXXAT	Capacitor	1206	100pF, 25V	3	Vishay
C27	C2012X5R1C105K	Capacitor	0805	1 $\mu$ F, 16V	1	TDK
C6, C16	C5750X5R1H106M	Capacitor	2220	10 $\mu$ F, 50V, 2.8A	2	TDK
C9, C23	6TPD330M	Capacitor	7.3x4.3x 3.8mm	330 $\mu$ F, 6.3V, 10m $\Omega$	2	Sanyo
C2, C11, C12, C13	VJ1206Y103KXXAT	Capacitor	1206	10nF, 25V	4	Vishay
C7, C25, C34	VJ1206Y104KXXAT	Capacitor	1206	100nF, 25V	3	Vishay
C19	VJ1206Y822KXXAT	Capacitor	1206	8.2nF, 10%	1	Vishay
C20	VJ1206Y153KXXAT	Capacitor	1206	15nF, 10%	1	Vishay
C26	C3216X7R1C475K	Capacitor	1206	4.7 $\mu$ F, 25V	1	TDK
R1	CRCW1206123J	Resistor	1206	12k $\Omega$ , 5%	1	Vishay
R2, R6, R14, R16	CRCW1206100J	Resistor	1206	100 $\Omega$ , 5%	1	Vishay
R13	CRCW1206682J	Resistor	1206	6.8k $\Omega$ , 12%	1	Vishay
R7, R15	WSL-2512 .010 1%	Resistor	2512	10m $\Omega$ , 1W	2	Vishay
R18, R9	CRCW1206000Z	Resistor	1206	0 $\Omega$	2	Vishay
R10	CRCW12062261F	Resistor	1206	2.26k $\Omega$ , 1%	1	Vishay
R23	CRCW12068451F	Resistor	1206	8.45k $\Omega$ , 1%	1	Vishay
R24	CRCW12061372F	Resistor	1206	13.7k $\Omega$ , 1%	1	Vishay
R11, R20	CRCW12064991F	Resistor	1206	4.99k $\Omega$ , 1%	2	Vishay
R19	CRCW12068251F	Resistor	1206	8.25k $\Omega$ , 1%	1	Vishay
R27	CRCW12064R7J	Resistor	1206	4.7 $\Omega$ , 5%	1	Vishay
R28	CRCW1206224J	Resistor	1206	220k $\Omega$ , 5%	1	Vishay

**Additional Footprints** (Continued)

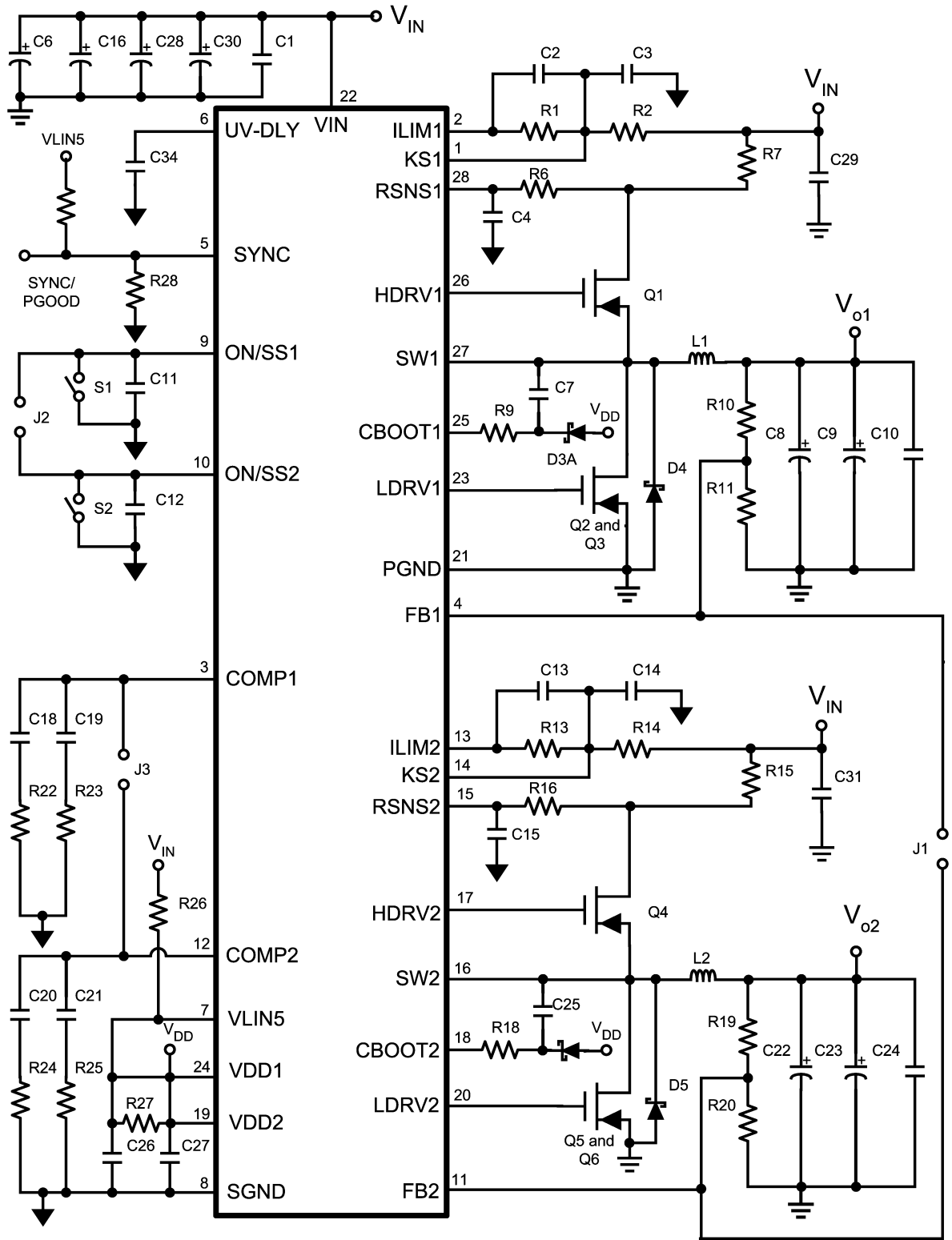

20077202

**FIGURE 2. Complete Resistor Sense Evaluation Board Schematic**

Additional Footprints (Continued)

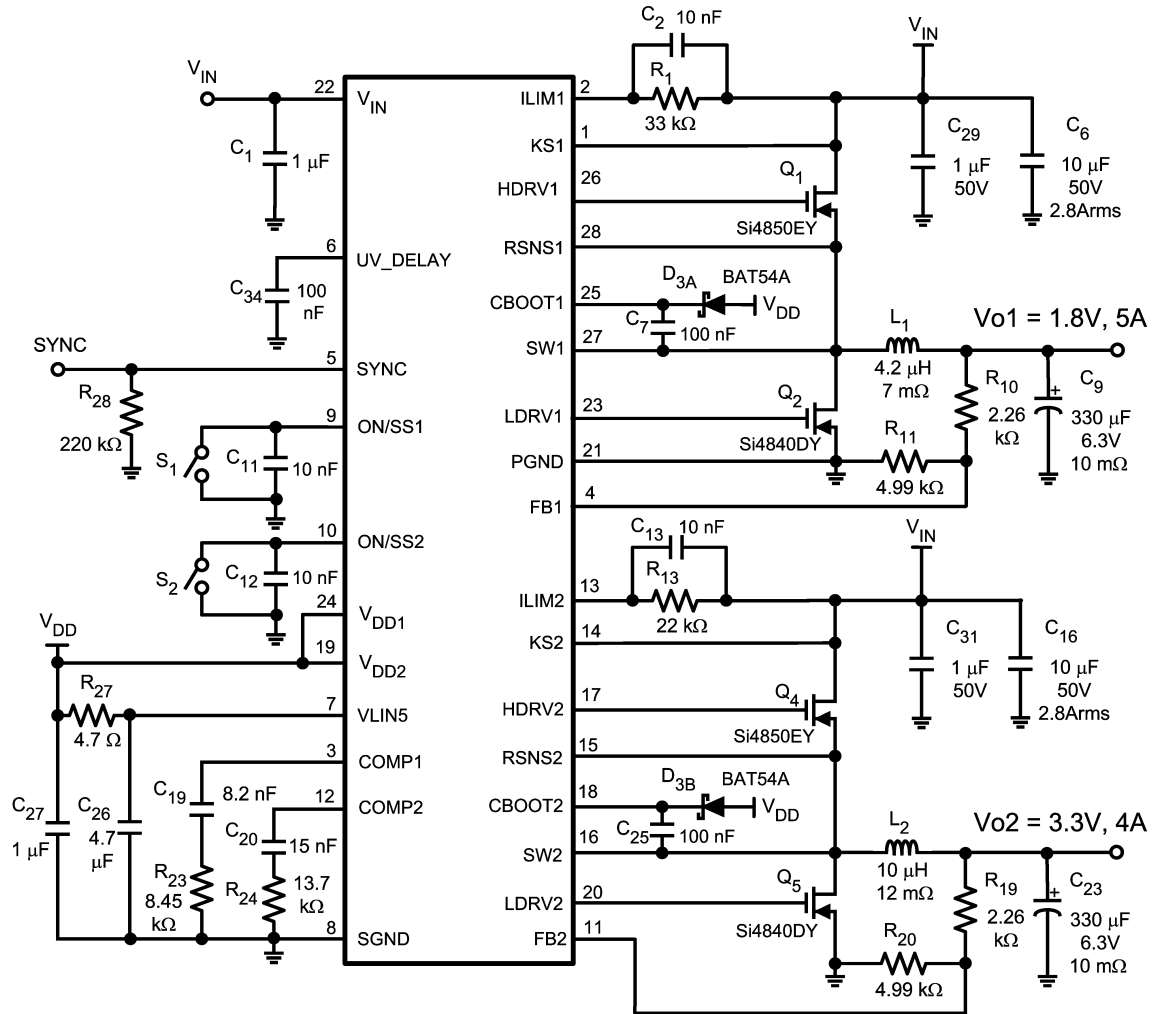

20077203

FIGURE 3. Standard  $V_{DS}$  Sense Circuit

Standard  $V_{DS}$  Sense BOM

ID	Part Number	Type	Size	Parameters	Qty	Vendor
U1	LM5642	Dual Synchronous Controller	TSSOP-28		1	NSC
Q1, Q4	Si4850EY	N-MOSFET	SO-8	60V	2	Vishay
Q2, Q5	Si4840DY	N-MOSFET	SO-8	40V	2	Vishay
D3	BAT54A	Schottky Diode	SOT-23	30V	1	ON
L1	RLF12560T-4R2N100	Inductor	12.5x12.5x 6mm	4.2μH, 7mΩ, 10A	1	TDK
L2	RLF12545T-100M5R1	Inductor	12.5x12.5x 4.5mm	10μH, 12mΩ, 5.1A	1	TDK
C1, C29, C31	C3216X7R1H105K	Capacitor	1206	1μF, 50V	1	TDK
C27	C2012X5R1C105K	Capacitor	0805	1μF, 16V	1	TDK
C6, C16	C5750X5R1H106M	Capacitor	2220	10μF, 50V, 2.8A	2	TDK
C9, C23	6TPD330M	Capacitor	7.3x4.3x 3.8mm	330μF, 6.3V, 10mΩ	2	Sanyo
C2, C11, C12, C13	VJ1206Y103KXXAT	Capacitor	1206	10nF, 25V	4	Vishay
C7, C25, C34	VJ1206Y104KXXAT	Capacitor	1206	100nF, 25V	3	Vishay
C19	VJ1206Y822KXXAT	Capacitor	1206	8.2nF, 10%	1	Vishay
C20	VJ1206Y153KXXAT	Capacitor	1206	15nF, 10%	1	Vishay

**Additional Footprints** (Continued)**Standard  $V_{DS}$  Sense BOM** (Continued)

ID	Part Number	Type	Size	Parameters	Qty	Vendor
C26	C3216X7R1C475K	Capacitor	1206	4.7 $\mu$ F, 25V	1	TDK
R1	CRCW1206333J	Resistor	1206	33k $\Omega$ , 5%	1	Vishay
R13	CRCW1206223J	Resistor	1206	22k $\Omega$ , 5%	1	Vishay
R10	CRCW12062261F	Resistor	1206	2.26k $\Omega$ , 1%	1	Vishay
R23	CRCW12068451F	Resistor	1206	8.45k $\Omega$ , 1%	1	Vishay
R24	CRCW12061372F	Resistor	1206	13.7k $\Omega$ , 1%	1	Vishay
R11, R20	CRCW12064991F	Resistor	1206	4.99k $\Omega$ , 1%	2	Vishay
R19	CRCW12068251F	Resistor	1206	8.25k $\Omega$ , 1%	1	Vishay
R27	CRCW12064R7J	Resistor	1206	4.7 $\Omega$ , 5%	1	Vishay
R28	CRCW1206224J	Resistor	1206	220k $\Omega$ , 5%	1	Vishay

Additional Footprints (Continued)

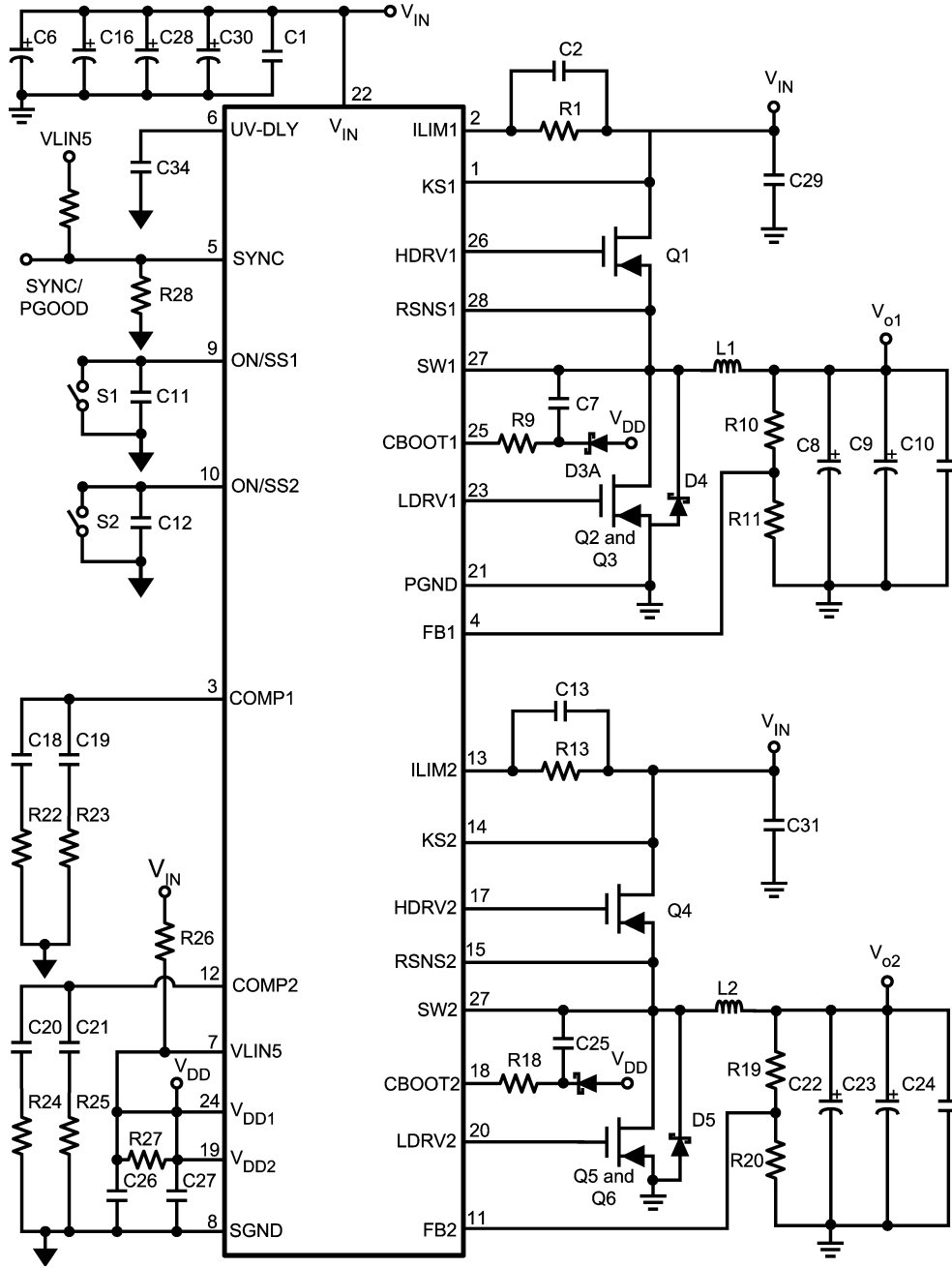

20077204

FIGURE 4. Complete  $V_{DS}$  Sense Eval Board Schematic

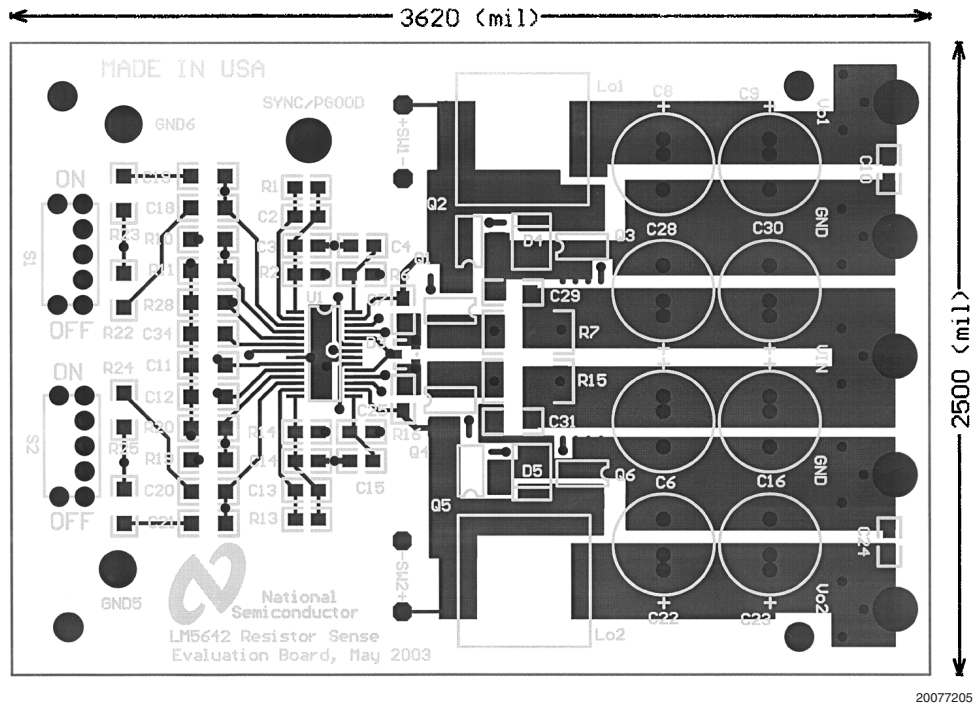

20077205

FIGURE 5. Resistor Sense PCB Top Layer

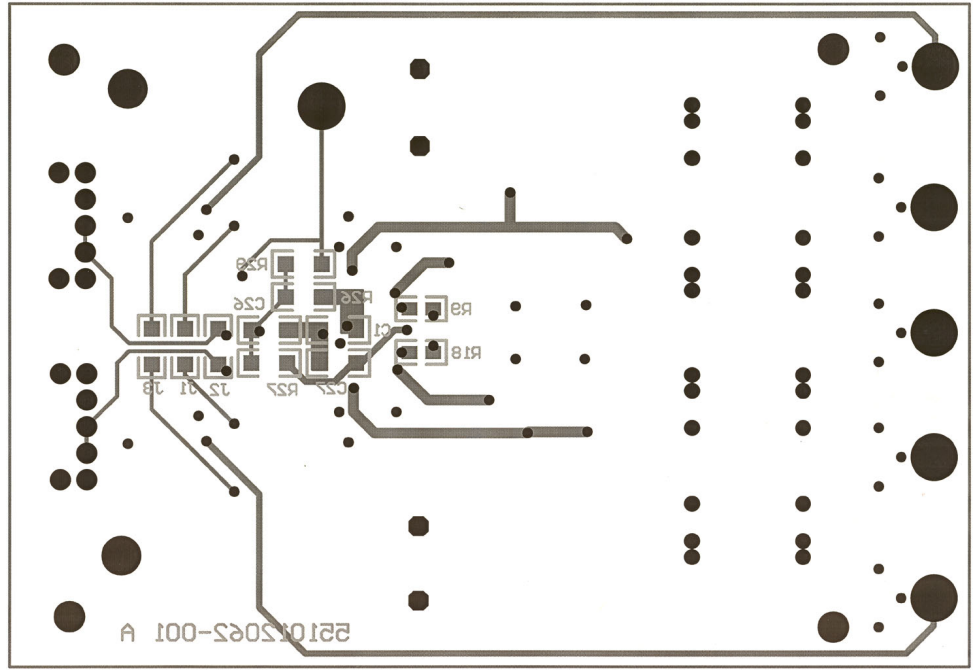

20077206

FIGURE 6. Resistor Sense PCB Bottom Layer



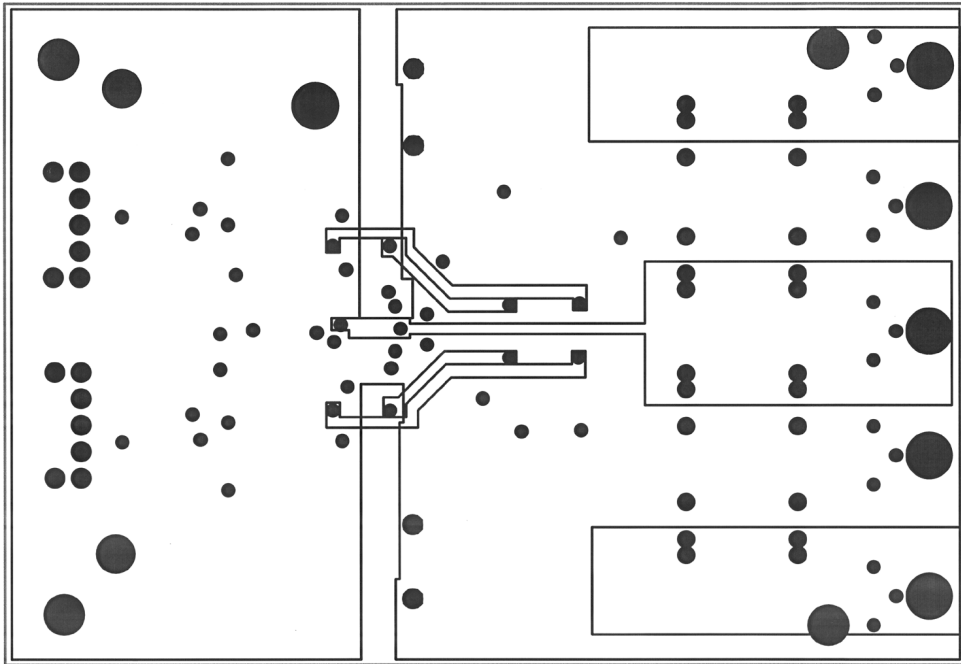

20077207

FIGURE 7. Resistor Sense PCB Internal Planes

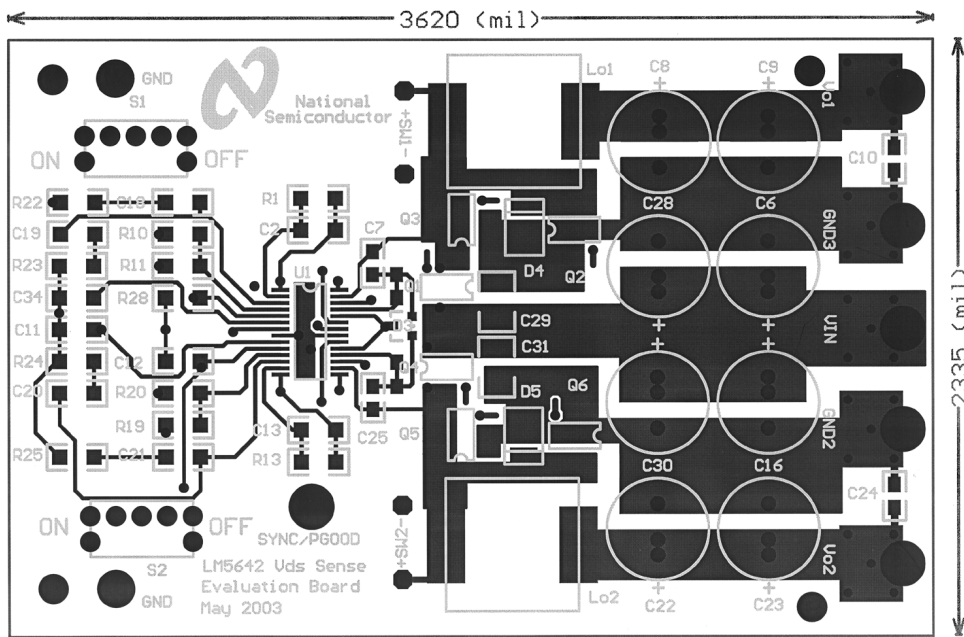

20077208

FIGURE 8.  $V_{DS}$  Sense PCB Top Layer

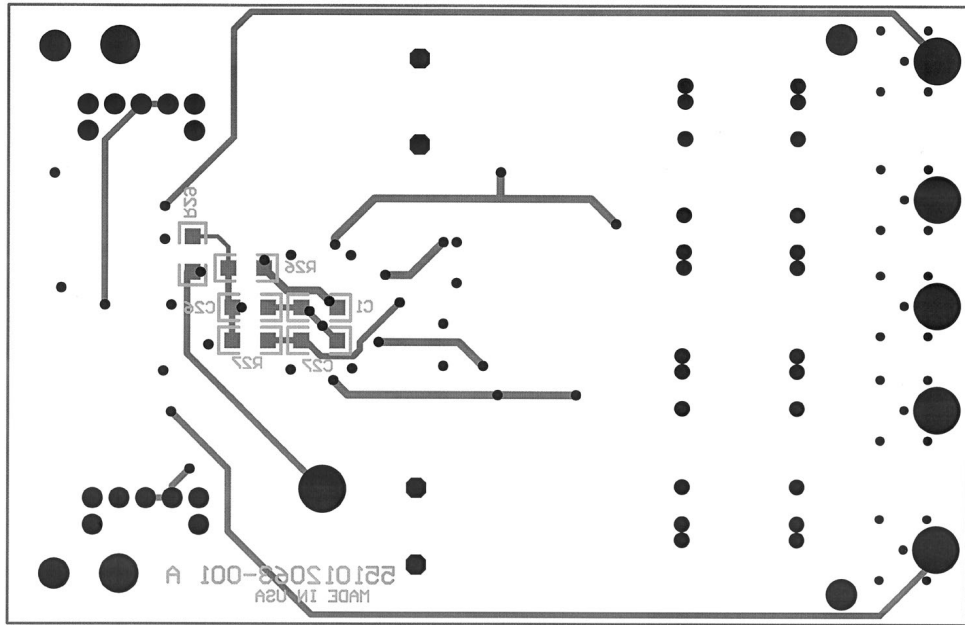

20077209

FIGURE 9.  $V_{DS}$  Sense PCB Bottom Layer

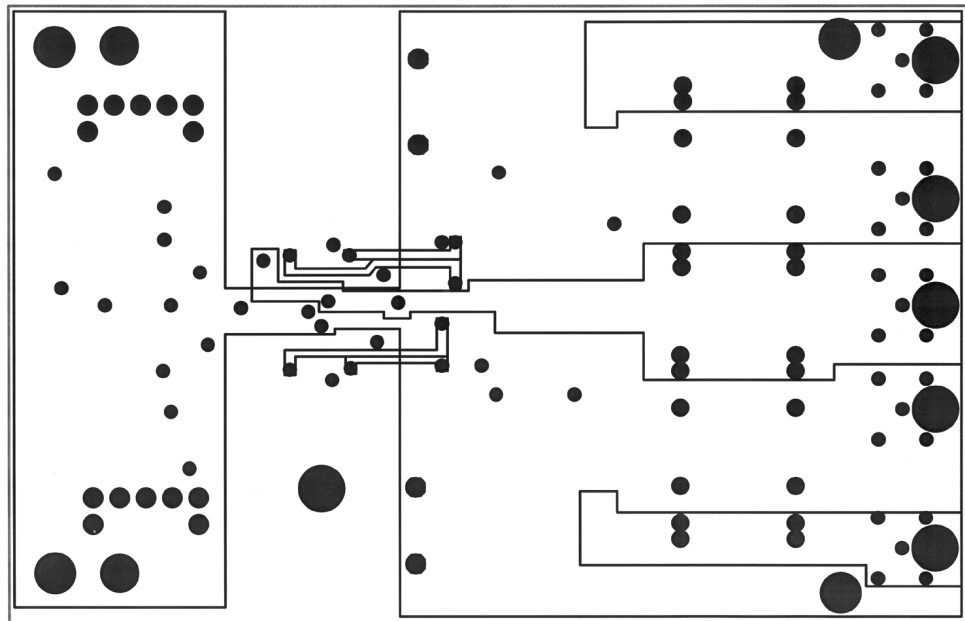

20077210

FIGURE 10.  $V_{DS}$  Sense PCB Internal Planes

## Notes

### LIFE SUPPORT POLICY

NATIONAL'S PRODUCTS ARE NOT AUTHORIZED FOR USE AS CRITICAL COMPONENTS IN LIFE SUPPORT DEVICES OR SYSTEMS WITHOUT THE EXPRESS WRITTEN APPROVAL OF THE PRESIDENT AND GENERAL COUNSEL OF NATIONAL SEMICONDUCTOR CORPORATION. As used herein:

1. Life support devices or systems are devices or systems which, (a) are intended for surgical implant into the body, or (b) support or sustain life, and whose failure to perform when properly used in accordance with instructions for use provided in the labeling, can be reasonably expected to result in a significant injury to the user.
2. A critical component is any component of a life support device or system whose failure to perform can be reasonably expected to cause the failure of the life support device or system, or to affect its safety or effectiveness.



**National Semiconductor**  
Americas Customer  
Support Center  
Email: new.feedback@nsc.com  
Tel: 1-800-272-9959

[www.national.com](http://www.national.com)

**National Semiconductor**  
Europe Customer Support Center  
Fax: +49 (0) 180-530 85 86  
Email: europe.support@nsc.com  
Deutsch Tel: +49 (0) 69 9508 6208  
English Tel: +44 (0) 870 24 0 2171  
Français Tel: +33 (0) 1 41 91 8790

**National Semiconductor**  
Asia Pacific Customer  
Support Center  
Email: ap.support@nsc.com

**National Semiconductor**  
Japan Customer Support Center  
Fax: 81-3-5639-7507  
Email: jpn.feedback@nsc.com  
Tel: 81-3-5639-7560